



## SMD Type Phototransistor with Daylight Filter

### Features

- Small double-end package
- High photo sensitivity
- High reliability
- Spectral range of sensitivity: 760-1100nm
- Fast Response time
- RoHS compliance

### Applications

- Infrared sensor
- Infrared Touch Panel Solutions

### Description

The PTP83016BT24 is silicon NPN Phototransistor housed in a miniature SMD package. The device comes with a superior filtering for visible light by utilizing special black molding compound.

### Package Outline

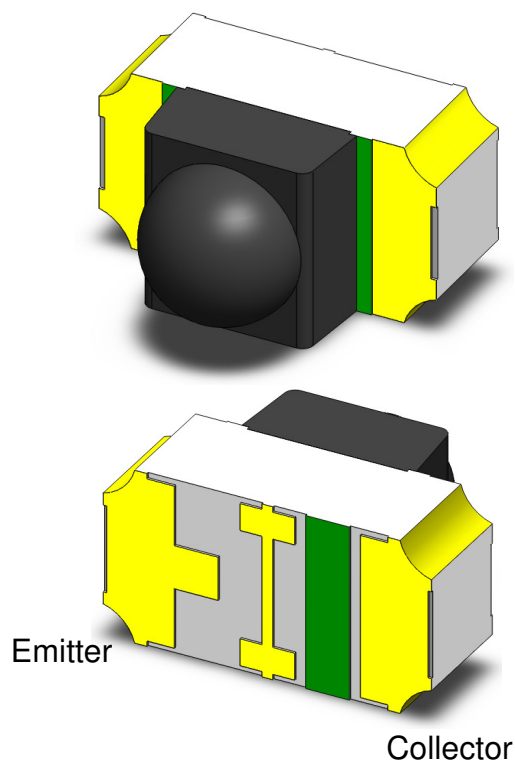

### Schematic

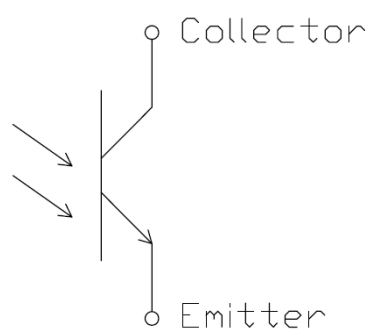



## SMD Type Phototransistor with Daylight Filter

## Absolute Maximum Rating at 25°C

Symbol	Parameters	Ratings	Units	Notes
I <sub>C</sub>	Collector Current	20	mA	
V <sub>CEO</sub>	Collector-Emitter Voltage	35	V	1
V <sub>ECO</sub>	Emitter-Collector Voltage	5	V	2
T <sub>opr</sub>	Operating Temperature	-40 ~ +85	°C	
T <sub>stg</sub>	Storage Temperature	-40 ~ +100	°C	
T <sub>sol</sub>	Soldering Temperature	260	°C	3
P <sub>to</sub>	Total Power Dissipation	150	mW	

## Optical Characteristics

Symbol	Parameters	Test Conditions	Min	Typ	Max	Units	Notes
λ	Spectral Bandwidth	-	760	-	1100	nm	
λ <sub>P</sub>	Peak Sensitivity	-	-	880	-	nm	
θ <sub>1/2</sub>	View Angle	V <sub>CE</sub> =5V	-	±22.5	-	deg	

## Electrical Characteristics

Symbol	Parameters	Test Conditions	Min	Typ	Max	Units	Notes
I <sub>CEO</sub>	Dark Current	Ee=0mW /cm <sup>2</sup> V <sub>CE</sub> =20V	-	-	100	nA	
V <sub>CE(sat)</sub>	Collector-Emitter Saturation Voltage	Ee=1mW /cm <sup>2</sup> I <sub>C</sub> =1.4mA	-	-	0.4	V	
I <sub>C</sub>	Collector Light Current	Ee=1mW /cm <sup>2</sup> λ <sub>P</sub> =940nm, V <sub>CE</sub> =5V	1.4	2.8	4.4	mA	4
C <sub>T</sub>	Terminal Capacitance	Ee=0mW /cm <sup>2</sup> f=1MHz, V <sub>CE</sub> =5V	-	3.80	-	pF	



# SMD Type Phototransistor with Daylight Filter

## Switching Characteristics

Symbol	Parameters	Test Conditions	Min	Typ	Max	Units	Notes
$t_r$	Rise Time	$V_{ce} = 5V, R_L = 100\Omega$ $I_C = 1.0mA$	-	6	-	$\mu s$	5
$t_f$	Fall Time		-	7	-		
$t_{on}$	Turn on Delay Time		-	11	-		
$t_{off}$	Turn off Delay Time		-	7.9	-		

**Notes:**

- 1 : Test conditions :  $I_C = 100\mu A, E_e = 0mW/cm^2$ .
- 2 : Test conditions :  $I_E = 100\mu A, E_e = 0mW/cm^2$ .
- 3 : Soldering time  $\leq 5$  seconds.
- 4 :  $I_C$  Bin Rank : (Tolerance of Collector Light Current :  $\pm 10\%$ )

Bin Code	Ta	Tb
Min	1.4	2.4
Max	2.4	4.4

5 : Test circuit:

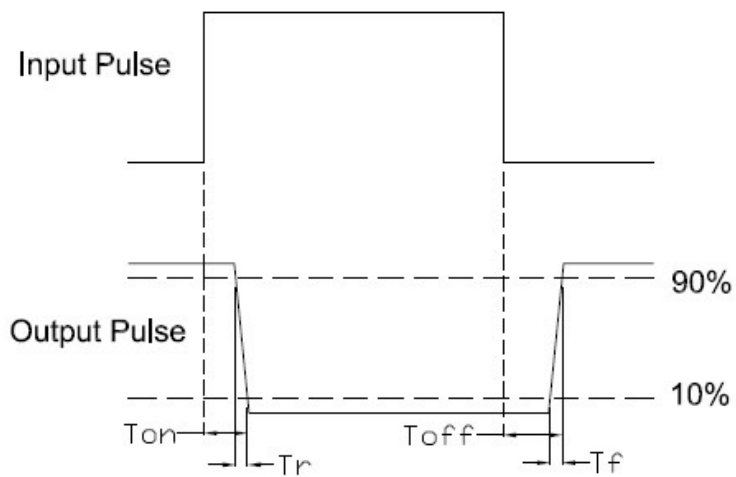
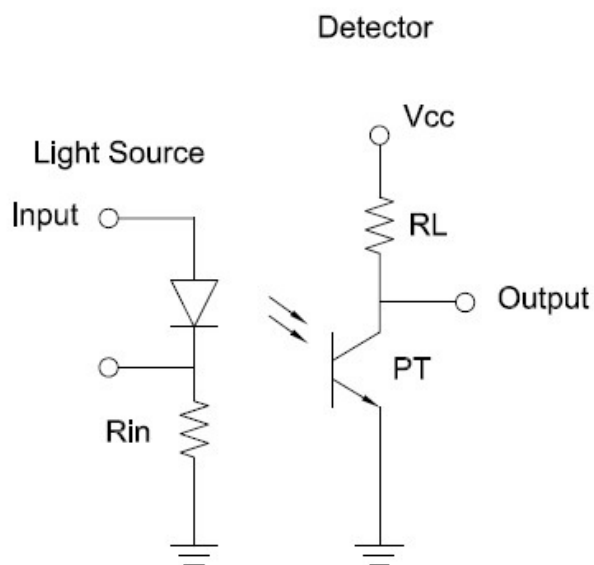

Switching Time



Typical Characteristic Curves

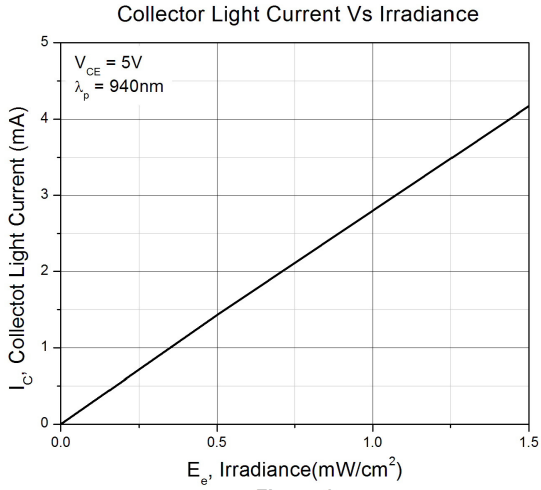

Figure 1

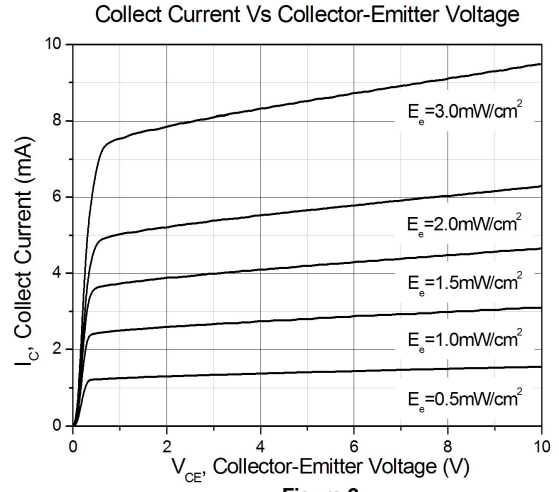

Figure 2

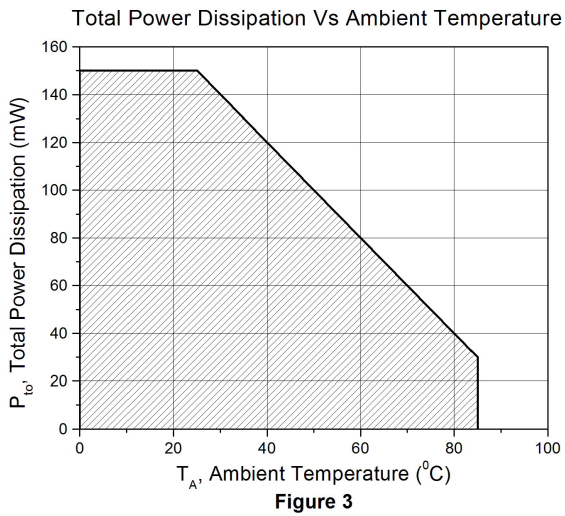

Figure 3

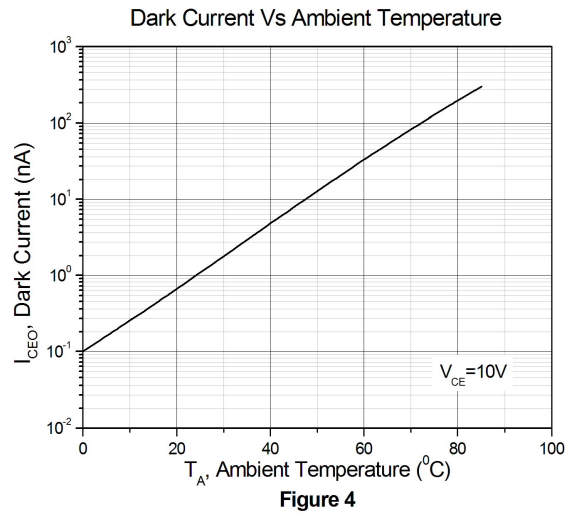

Figure 4

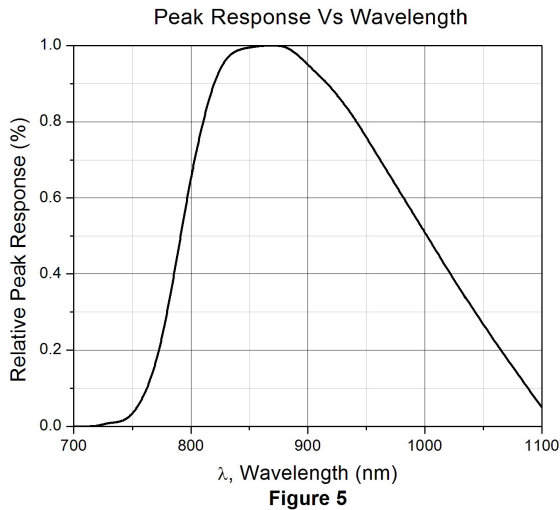

Figure 5

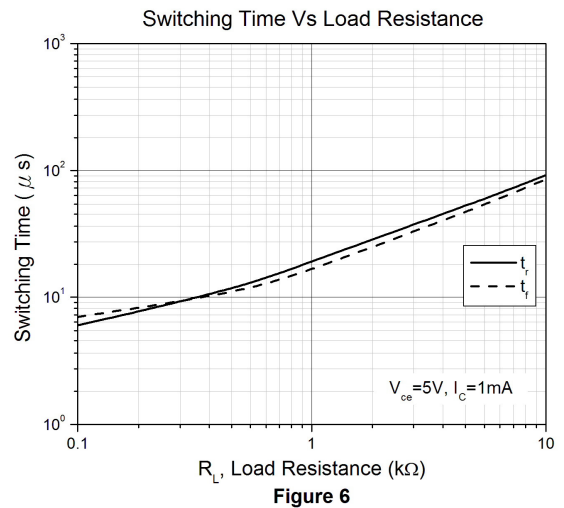
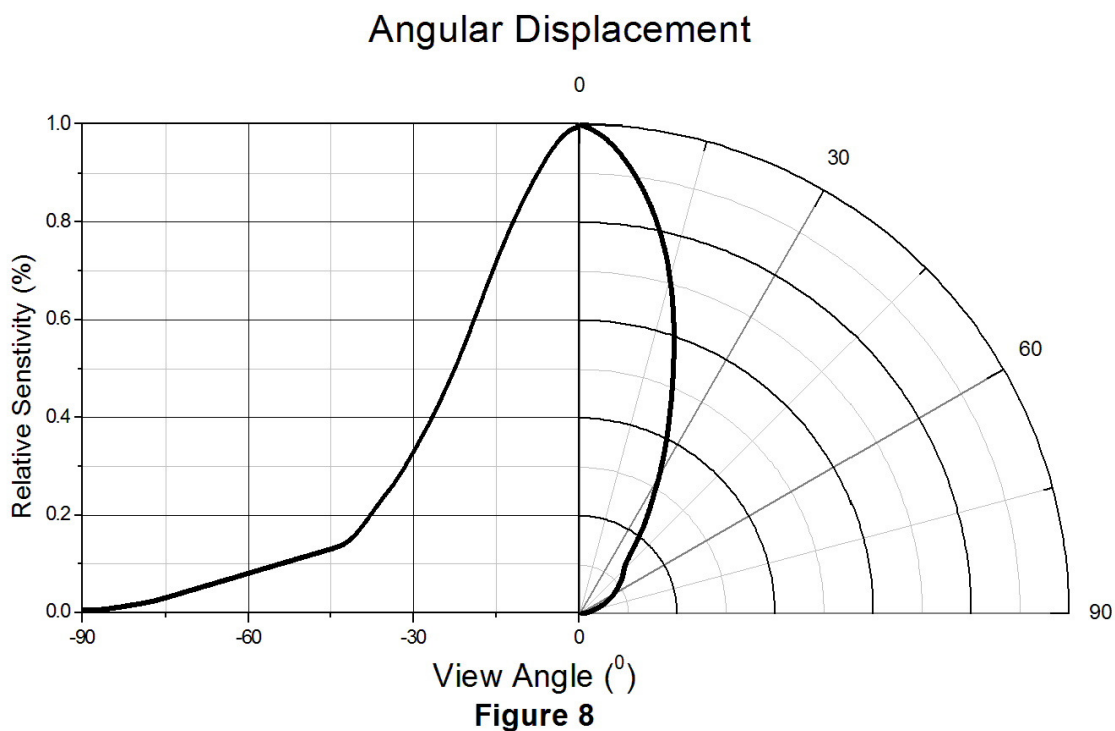
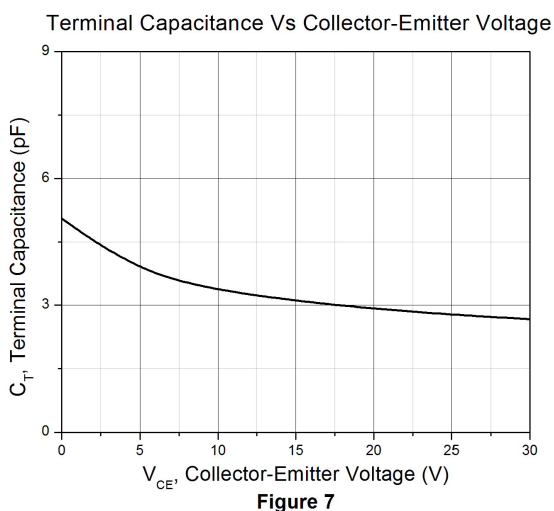

Figure 6



### Typical Characteristic Curves





SMD Type Phototransistor with Daylight Filter

**Package Dimension** *All dimensions are in mm, unless otherwise stated*

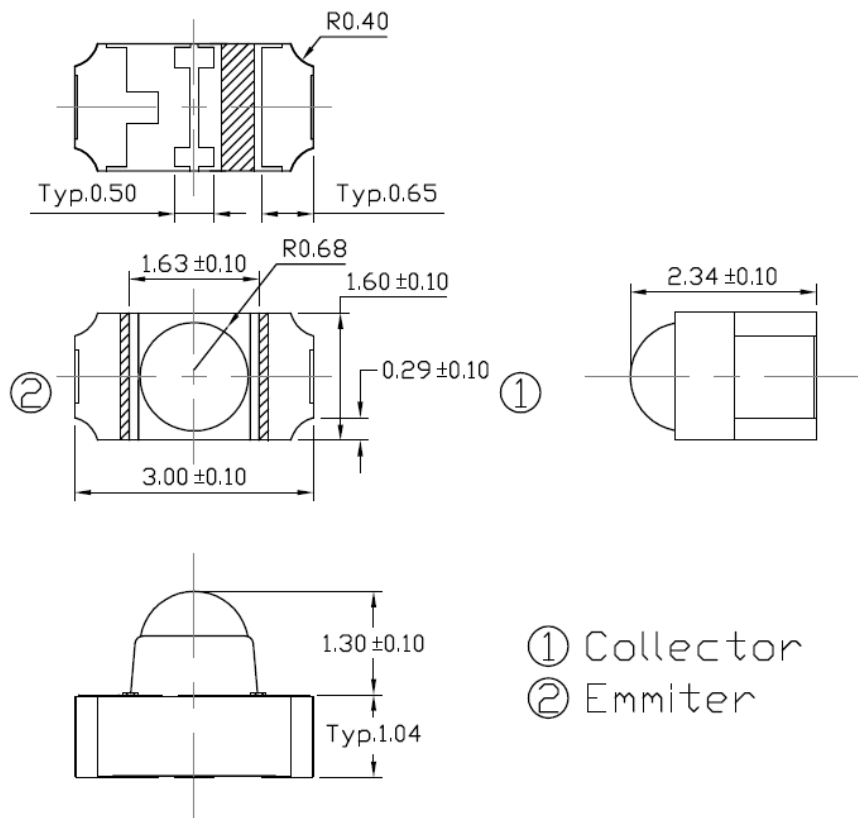

**Recommended Soldering Mask** *All dimensions are in mm, unless otherwise stated*

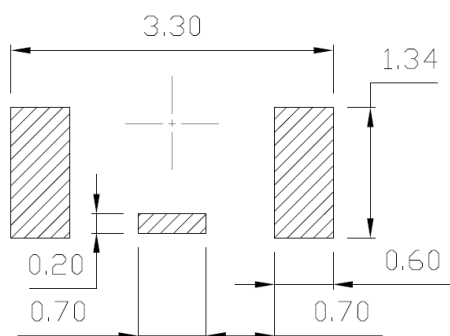

**Ordering Information**

Part Number	Description	Quantity
PTP83016BT24	Tape & Reel	2000 pcs



PTP83016BT24

## SMD Type Phototransistor with Daylight Filter

**Reel Dimension** *All dimensions are in mm, unless otherwise stated*

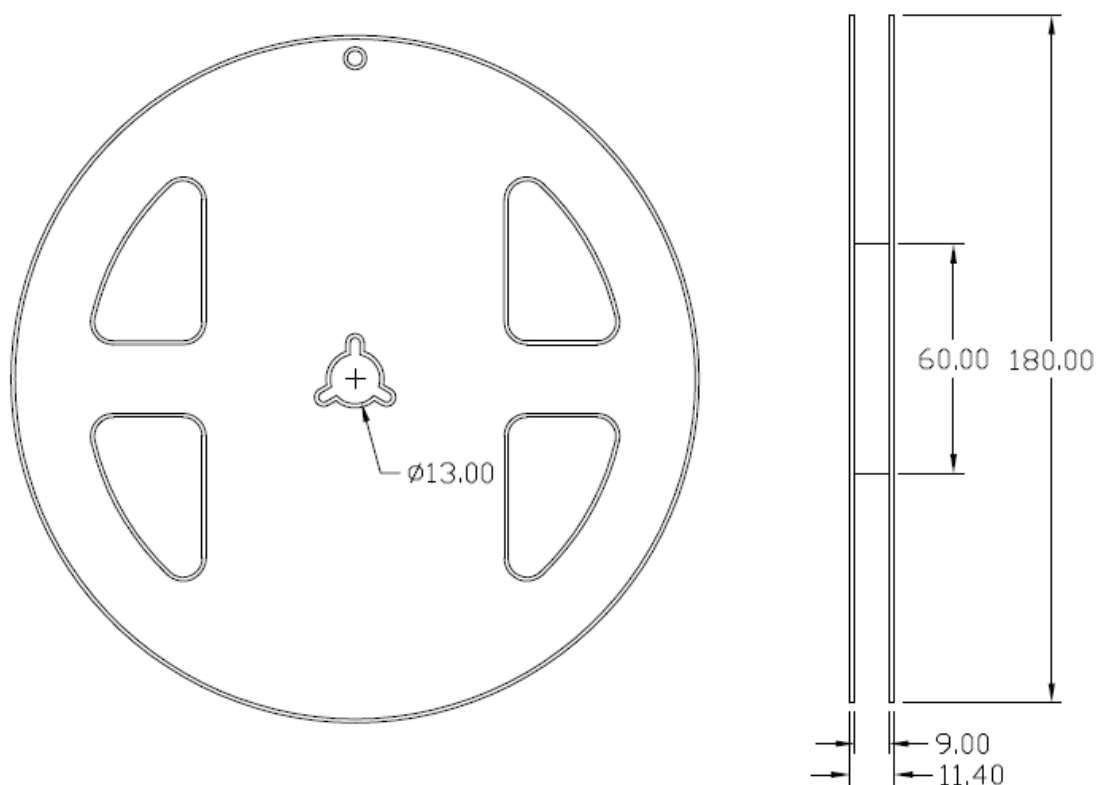

**Tape Dimension** *All dimensions are in mm, unless otherwise stated*

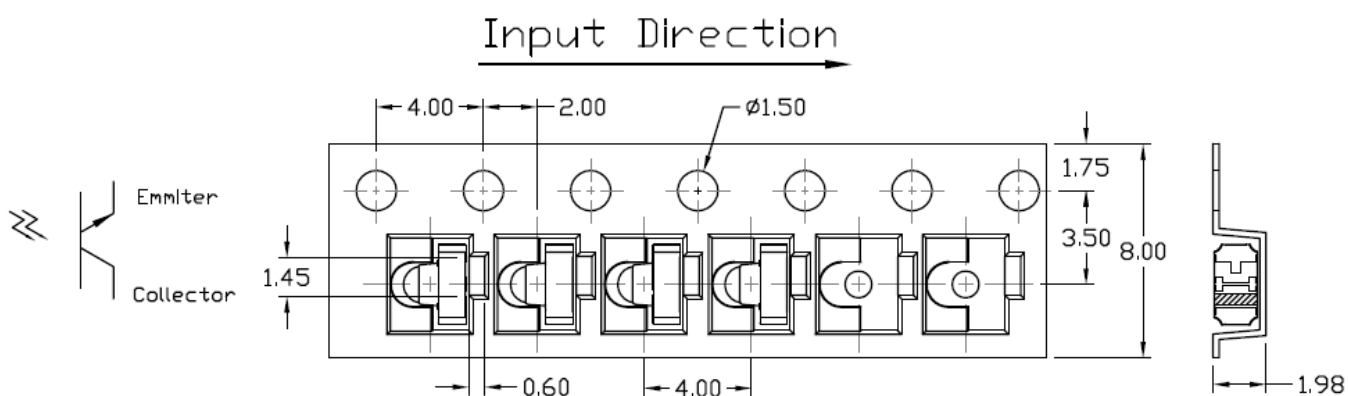



## SMD Type Phototransistor with Daylight Filter

### Reflow Profile

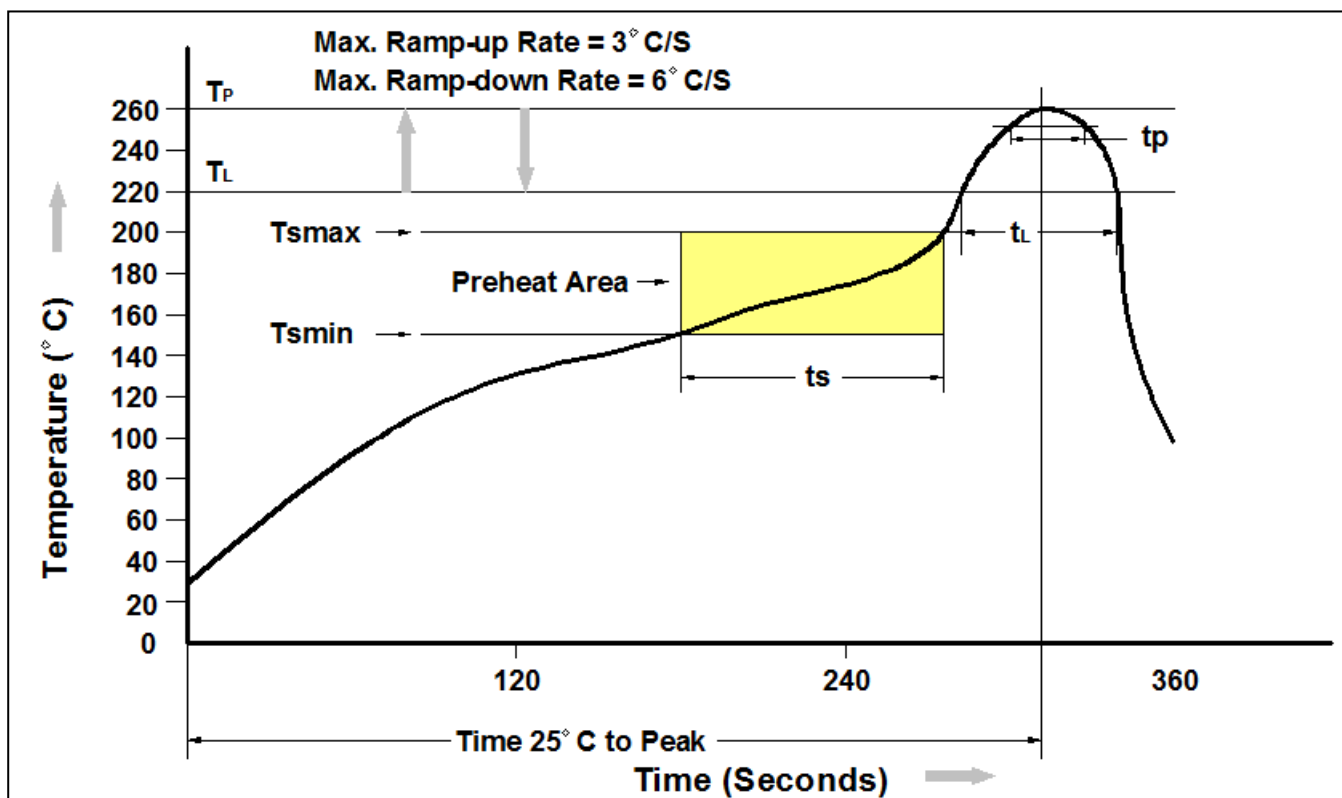

Profile Feature	Pb-Free Assembly Profile
Temperature Min. (Tsmmin)	150 °C
Temperature Max. (Tsmmax)	200 °C
Time (ts) from (Tsmmin to Tsmmax)	60-120 seconds
Ramp-up Rate (tL to tP)	3 °C/second max.
Liquidous Temperature (TL)	217 °C
Time (tL) Maintained Above (TL)	60 – 150 seconds
Peak Body Package Temperature	260 °C +0 °C / -5 °C
Time (tP) within 5 °C of 260 °C	30 seconds
Ramp-down Rate (TP to TL)	6 °C/second max
Time 25 °C to Peak Temperature	8 minutes max.





## SMD Type Phototransistor with Daylight Filter

---

### DISCLAIMER

CT MICRO RESERVES THE RIGHT TO MAKE CHANGES WITHOUT FURTHER NOTICE TO ANY PRODUCTS HEREIN TO IMPROVE RELIABILITY, FUNCTION OR DESIGN. CT MICRO DOES NOT ASSUME ANY LIABILITY ARISING OUT OF THE APPLICATION OR USE OF ANY PRODUCT OR CIRCUIT DESCRIBED HEREIN; NEITHER DOES IT CONVEY ANY LICENSE UNDER ITS PATENT RIGHTS, NOR THE RIGHTS OF OTHERS.

---

CT MICRO ARE NOT AUTHORIZED FOR USE AS CRITICAL COMPONENTS IN LIFE SUPPORT DEVICES OR SYSTEMS WITHOUT EXPRESS WRITTEN APPROVAL OF CT MICRO INTERNATIONAL CORPORATION.

- 1. Life support devices or systems are devices or systems which, (a) are intended for surgical implant into the body, or (b) support or sustain life, or (c) whose failure to perform when properly used in accordance with instruction for use provided in the labelling, can be reasonably expected to result in significant injury to the user.*
- 2. A critical component is any component of a life support device or system whose failure to perform can be reasonably expected to cause the failure of the life support device or system, or to affect its safety or effectiveness.*