

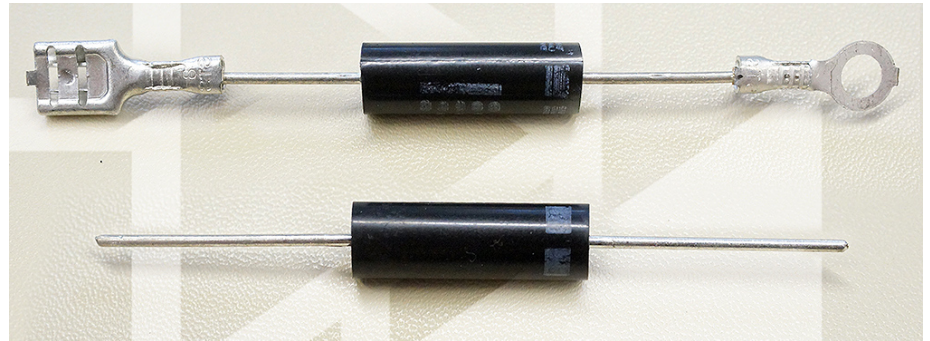

**FEATURES**

- High Overload Surge Capacity
- Durable Epoxy Resin Package



To order with quick disconnect terminals, use the **partnum-TERM**

**ABSOLUTE MAXIMUM RATINGS**

$V_{RRM}$ Repeating Peak Reverse Voltage (kV):	15
$T_{JMAX}$ Max. junction temp.(°C):	125
$T_{STG}$ Storage temp.(°C):	-40 to +125
$I_O$ Avg. Forward Current (mA):	300
$I_{FSM}$ Forward Surge Current (A):	30

**ELECTRICAL CHARACTERISTICS**

$I_{R1}$ Normal temp. Reverse Current ( $\mu A$ ) @ $V_R=V_{RRM}, T_{amb}=25^\circ C$ :	5.0 max
$I_{R2}$ High temp. Reverse Current ( $\mu A$ ) @ $V_R=V_{RRM}, T_{amb}=100^\circ C$ :	50 max
$V_F$ Forward Voltage Drop (V) @ $I_F=300mA$ :	24.0
$T_{RR}$ Reverse Recovery Time (nS) @ $I_F=50mA, I_R=100mA$ :	100

**TEST CONDITIONS**

High temp. Reverse Voltage @ 1000 hrs.:	$V_{RM}=V_{RRM}, f=50Hz, T_{AMB}=100^\circ C$ Half sine voltage with $f=50Hz$ applied, $T_{AMB}=100^\circ C$
High temp. storage @ 1000 Hrs.:	$T_{AMB}=130\pm 2^\circ C$
Soldering Resistance Heat Test:	Solder trough temp.: $350\pm 10^\circ C$ , Dip Time: $3.5s \pm 0.5s$
High pressure smoke test @ 10 hrs.:	$120^\circ C, 2 \times 10^5 pa$
Insulation Resistance Test (1000M $\Omega$ ):	Between the center of the body and terminal (See Fig. 1)
Insulation Strength Test @ 10KV:	1 min. between center of the body and terminal. (Fig.1)
Lead bend test:	Force 10 N to the lead, bent it to pos. and neg. $90^\circ$
Lead pull test:	Force 70 N of axial to the lead for 1 min.

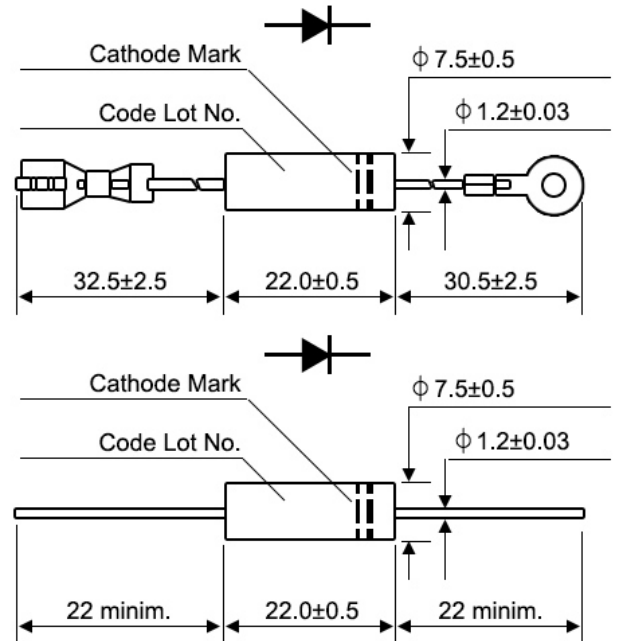

Insulation resistance test condition: Measure between A and B by using a DC 500V Insulation resistance tester

Insulation strength test condition: Apply half sine wave voltage with 10kV wave height between A and B in insulation liquid

