

Aluminum electrolytic capacitors

Snap-in capacitors

Series/Type: B43541
Date: October 2015

© EPCOS AG 2015. Reproduction, publication and dissemination of this publication, enclosures hereto and the information contained therein without EPCOS' prior express consent is prohibited.

EPCOS AG is a TDK Group Company.

Long-life grade capacitors

Applications

- Frequency converters
- Solar inverters
- Uninterruptible power supplies
- Professional power supplies
- Medical appliances



Features

- Voltage derating ($0.91 \cdot V_R$) enables 105 °C operation, more details available upon request
- Base cooling available upon request for case sizes 30 × 35 mm to 35 × 55 mm
- Rated voltages up to 600 V
- Long useful life
- High reliability
- Outstanding ripple current capability
- Extremely improved performance at high frequencies
- Outstanding low ESR at operating conditions above 50 °C
- High CV product, compact
- Optimized internal thermal resistance
- Different case sizes available for each capacitance value
- Capacitors with all insulation versions pass the needle flame test according to IEC 60695-11-5 for all flame exposure times up to 120 s
- RoHS-compatible

Construction

- Charge/discharge-proof, polar
- Aluminum case, fully insulated with PVC
- Version with PET insulation available
- Version with additional PET insulation cap on terminal side available for insulating the capacitor from the PCB
- Snap-in solder pins to hold component in place on PC-board
- Minus pole marking on case surface
- Minus pole not insulated from case
- Overload protection by safety vent on the case wall

Terminals

- Standard version with 2 terminals, 2 lengths available: 6.3 and 4.5 mm
- 3 terminals to ensure correct insertion: length 4.5 mm

Specifications and characteristics in brief

Rated voltage V_R	200 ... 600 V DC				
Surge voltage V_S	1.15 · V_R (for $V_R \leq 250$ V DC) 1.10 · V_R (for $V_R \geq 400$ V DC)				
Rated capacitance C_R	47 ... 2200 μF				
Capacitance tolerance	$\pm 20\% \triangleq M$				
Dissipation factor $\tan \delta$ (20 °C, 120 Hz)	$V_R \leq 400$ V DC: $\tan \delta \leq 0.15$ $V_R \geq 450$ V DC: $\tan \delta \leq 0.20$				
Leakage current I_{leak} (5 min, 20 °C)	$I_{\text{leak}} \leq 0.3 \mu\text{A} \cdot \left(\frac{C_R}{\mu\text{F}} \cdot \frac{V_R}{V} \right)^{0.7} + 4 \mu\text{A}$				
Self-inductance ESL	Approx. 20 nH				
Useful life ¹⁾ 85 °C; V_R ; $I_{\text{AC,R}}$	≤ 500 V	≥ 550 V	Requirements: $ \Delta C/C \leq 20\%$ of initial value $\tan \delta \leq 2$ times initial specified limit $I_{\text{leak}} \leq$ initial specified limit		
	> 8000 h	> 5000 h			
Voltage endurance test 85 °C; V_R	≤ 500 V	≥ 550 V	Post test requirements: $ \Delta C/C \leq 10\%$ of initial value $\tan \delta \leq 1.3$ times initial specified limit $I_{\text{leak}} \leq$ initial specified limit		
	4000 h	2000 h			
Vibration resistance test	To IEC 60068-2-6, test Fc: Frequency range 10 Hz ... 55 Hz, displacement amplitude 0.35 mm, acceleration max. 5 g, duration 3 × 2 h. Capacitor mounted by its body which is rigidly clamped to the work surface.				
Characteristics at low temperature	Max. impedance ratio at 100 Hz	V_R	≤ 400 V	450 V	≥ 500 V
		$Z_{-25^\circ\text{C}} / Z_{20^\circ\text{C}}$	3	4	5
		$Z_{-40^\circ\text{C}} / Z_{20^\circ\text{C}}$	7	10	14
IEC climatic category	To IEC 60068-1: $V_R \leq 450$ V DC: 40/085/56 (–40 °C/+85 °C/56 days damp heat test) $V_R \geq 500$ V DC: 25/085/56 (–25 °C/+85 °C/56 days damp heat test) The capacitors can be operated in the temperature range of –40 °C to +85 °C, but the impedance at –40 °C should be taken into consideration.				
Detail specification	Similar to CECC 30301-811				
Sectional specification	IEC 60384-4				

1) Refer to chapter "General technical information, 5 Useful life" on how to interpret useful life.



B43541

Outstanding ripple current, high voltage – 85 °C

Dimensional drawings

Snap-in capacitors with standard insulation (PVC or PET)

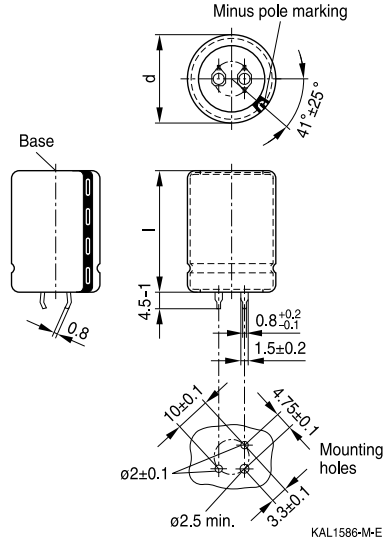
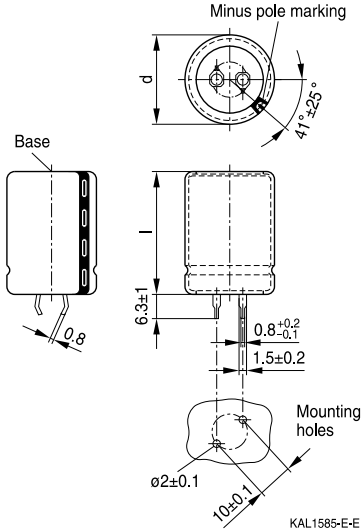

Snap-in terminals, length (6.3 ±1) mm.
 Also available in a shorter version with a length of (4.5 – 1) mm. PET insulation is marked with label "PET" on the sleeve. Safety vent on the case wall.

Snap-in capacitors are also available with 3 terminals (length (4.5 – 1) mm). PET insulation is marked with label "PET" on the sleeve. Safety vent on the case wall.

Dimensions (mm)		Approx. weight (g)	Packing units (pcs.)
d +1	l ±2		
25	25	13	130
25	30	17	130
25	35	19	130
25	40	22	130
25	45	25	130
25	50	29	130
25	55	32	130

Dimensions (mm)		Approx. weight (g)	Packing units (pcs.)
d +1	l ±2		
30	25	17	80
30	30	23	80
30	35	29	80
30	40	36	80
30	45	41	80
30	50	46	80
30	55	53	80
35	25	22	60
35	30	29	60
35	35	36	60
35	40	41	60
35	45	56	60
35	50	70	60
35	55	81	60

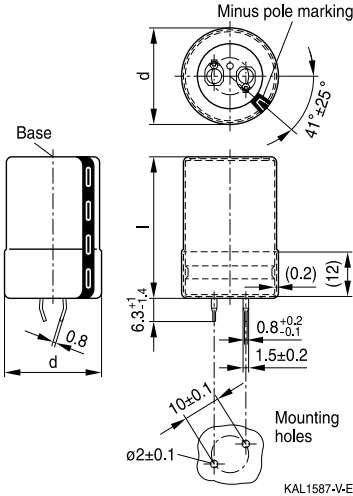
Snap-in capacitors with PVC insulation and PET insulation cap on terminal side

KAL1587-V-E

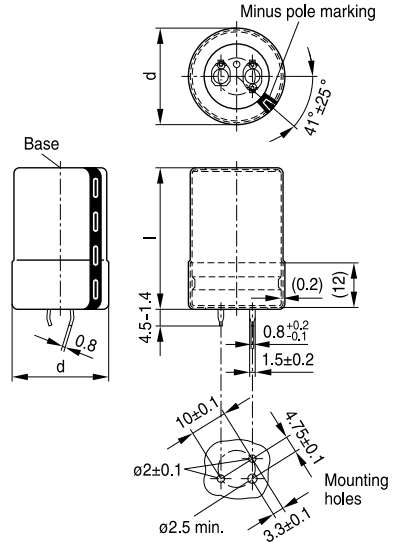

KAL1588-4-E

Snap-in terminals, length $(6.3 +1/-1.4)$ mm. Also available in a shorter version with a length of $(4.5 - 1.4)$ mm. PET insulation cap is positioned under the insulation sleeve. Safety vent on the case wall.

Snap-in capacitors are also available with 3 terminals (length $(4.5 - 1.4)$ mm). PET insulation cap is positioned under the insulation sleeve. Safety vent on the case wall.

Dimensions (mm)		Approx. weight (g)	Packing units (pcs.)
$d + 1.4$	$l + 2.2/-2$		
25	25	13	115
25	30	17	115
25	35	19	115
25	40	22	115
25	45	25	115
25	50	29	115
25	55	32	115

Dimensions (mm)		Approx. weight (g)	Packing units (pcs.)
$d + 1.4$	$l + 2.2/-2$		
30	25	17	80
30	30	23	80
30	35	29	80
30	40	36	80
30	45	41	80
30	50	46	80
30	55	53	80
35	25	22	60
35	30	29	60
35	35	36	60
35	40	41	60
35	45	56	60
35	50	70	60
35	55	81	60



B43541

Outstanding ripple current, high voltage – 85 °C

Packing of snap-in capacitors



For ecological reasons the packing is pure cardboard. Components can be withdrawn (in full or in part) in the correct position for insertion.

Ordering codes for terminal styles and insulation features

Identification in 3rd block of ordering code

Snap-in capacitors

Terminal version	Insulation version		
	PVC	PET	PVC plus PET cap
Standard terminals 6.3 mm	M000	M060	M080
Short terminals 4.5 mm	M007	M067	M087
3 terminals 4.5 mm	M002	M062	M082

Ordering examples:

- B43541A7107M007 } snap-in capacitor with short terminals and standard PVC insulation
- B43541A7107M062 } snap-in capacitor with 3 terminals and PET insulation
- B43541A7107M080 } snap-in capacitor with standard terminals and PVC insulation with additional PET insulation cap on terminal side

Overview of available types

V_R (V DC)	200	250	400	450	500	550	600
	Case dimensions $d \times l$ (mm)						
C_R (μ F)							
47							25 × 25
56						25 × 25	25 × 30
68				25 × 25	25 × 25	25 × 30	25 × 35 30 × 25
82				25 × 30	25 × 30	25 × 35 30 × 25	25 × 35 30 × 30
100			25 × 25	25 × 30 30 × 25	25 × 30 30 × 25	25 × 35 30 × 30	25 × 40 30 × 35 35 × 25
120			25 × 30	25 × 35 30 × 30	25 × 35 30 × 30	25 × 40 30 × 35 35 × 25	25 × 50 30 × 35 35 × 30
150			25 × 35 30 × 25	25 × 35 30 × 30 35 × 25	25 × 40 30 × 30 35 × 25	25 × 50 30 × 35 35 × 30	25 × 55 30 × 45 35 × 35
180			25 × 35 30 × 30 35 × 25	25 × 45 30 × 35 35 × 30	25 × 45 30 × 35 35 × 30	25 × 55 30 × 40 35 × 35	30 × 50 35 × 40
220			25 × 40 30 × 30 35 × 30	25 × 50 30 × 40 35 × 30	25 × 55 30 × 40 35 × 35	30 × 50 35 × 40	30 × 55 35 × 45
270		25 × 25	25 × 45 30 × 35 35 × 30	25 × 55 30 × 40 35 × 35	30 × 45 35 × 35	30 × 55 35 × 45	35 × 50
330	25 × 25	25 × 30	25 × 55 30 × 40 35 × 35	30 × 50 35 × 40	30 × 55 35 × 40	35 × 50	
390	25 × 30 30 × 25	25 × 35 30 × 25	30 × 45 35 × 35	30 × 55 35 × 45	35 × 45	35 × 55	
470	25 × 30 30 × 25	25 × 35 30 × 30	30 × 50 35 × 40	35 × 50	35 × 55		
560	25 × 35 30 × 30	25 × 40 30 × 30 35 × 25	35 × 50	35 × 55			

B43541
Outstanding ripple current, high voltage – 85 °C

V_R (V DC)	200	250	400	450	500	550	600
	Case dimensions $d \times l$ (mm)						
C_R (μ F)							
680	25 × 40 30 × 30 35 × 25	25 × 45 30 × 35 35 × 30	35 × 55				
820	25 × 45 30 × 35 35 × 30	25 × 55 30 × 40 35 × 35					
1000	25 × 50 30 × 40 35 × 30	30 × 45 35 × 35					
1200	30 × 45 35 × 35	30 × 55 35 × 40					
1500	30 × 50 35 × 40	35 × 50					
1800	35 × 45	35 × 55					
2200	35 × 55						

The capacitance and voltage ratings listed above are available in different cases upon request. Other voltage and capacitance ratings are also available upon request.

Technical data and ordering codes

C_R	Case dimensions	ESR_{typ} 100 Hz 20 °C	ESR_{typ} 300 Hz 60 °C	Z_{max} 10 kHz 20 °C	$I_{AC,max}$ 100 Hz 60 °C	$I_{AC,R}$ 100 Hz 85 °C	Ordering code (composition see below)
μF	d × l mm	m Ω	m Ω	m Ω	A	A	
$V_R = 200 V DC$							
330	25 × 25	300	100	440	2.93	1.63	B43541A2337M0*#
390	25 × 30	250	80	370	3.34	1.86	B43541A2397M0*#
390	30 × 25	240	70	360	3.68	2.05	B43541B2397M0*#
470	25 × 30	210	70	310	3.66	2.04	B43541A2477M0*#
470	30 × 25	200	60	300	4.08	2.27	B43541B2477M0*#
560	25 × 35	180	60	260	4.18	2.33	B43541A2567M0*#
560	30 × 30	170	50	250	4.61	2.58	B43541B2567M0*#
680	25 × 40	140	50	220	4.79	2.67	B43541A2687M0*#
680	30 × 30	140	45	210	5.14	2.86	B43541B2687M0*#
680	35 × 25	140	50	220	5.20	2.90	B43541C2687M0*#
820	25 × 45	120	40	180	5.46	3.05	B43541A2827M0*#
820	30 × 35	120	36	180	5.86	3.27	B43541B2827M0*#
820	35 × 30	120	40	180	6.09	3.55	B43541C2827M0*#
1000	25 × 50	100	36	150	6.25	3.49	B43541A2108M0*#
1000	30 × 40	95	30	150	6.84	3.99	B43541B2108M0*#
1000	35 × 30	100	36	150	6.67	3.88	B43541C2108M0*#
1200	30 × 45	80	26	120	7.76	4.52	B43541A2128M0*#
1200	35 × 35	85	28	130	7.60	4.42	B43541B2128M0*#
1500	30 × 50	65	22	95	9.02	5.25	B43541A2158M0*#
1500	35 × 40	65	24	100	8.76	5.10	B43541B2158M0*#
1800	35 × 45	55	20	85	9.89	5.76	B43541A2188M0*#
2200	35 × 55	45	16	70	11.5	6.72	B43541A2228M0*#

Composition of ordering code

* = Insulation feature

0 = PVC insulation

6 = PET insulation

8 = PVC insulation with additional PET insulation cap on terminal side

= Terminal style

0 = snap-in standard terminals (6.3 mm)

2 = snap-in 3 terminals (4.5 mm)

7 = snap-in short terminals (4.5 mm)

B43541
Outstanding ripple current, high voltage – 85 °C
Technical data and ordering codes

C_R	Case dimensions	ESR_{typ} 100 Hz 20 °C	ESR_{typ} 300 Hz 60 °C	Z_{max} 10 kHz 20 °C	$I_{AC,max}$ 100 Hz 60 °C	$I_{AC,R}$ 100 Hz 85 °C	Ordering code (composition see below)
μF	mm	m Ω	m Ω	m Ω	A	A	
$V_R = 250$ V DC							
270	25 × 25	310	100	440	2.74	1.53	B43541E2277M0*#
330	25 × 30	250	80	360	3.17	1.78	B43541E2337M0*#
390	25 × 35	210	70	300	3.59	2.01	B43541E2397M0*#
390	30 × 25	210	65	290	3.83	2.14	B43541F2397M0*#
470	25 × 35	180	60	260	3.97	2.22	B43541E2477M0*#
470	30 × 30	170	55	240	4.36	2.44	B43541F2477M0*#
560	25 × 40	150	50	210	4.51	2.52	B43541E2567M0*#
560	30 × 30	140	45	210	4.81	2.69	B43541F2567M0*#
560	35 × 25	150	50	220	4.88	2.72	B43541G2567M0*#
680	25 × 45	120	45	180	5.17	2.89	B43541E2687M0*#
680	30 × 35	120	38	170	5.51	3.08	B43541F2687M0*#
680	35 × 30	120	40	180	5.62	3.34	B43541G2687M0*#
820	25 × 55	100	36	150	6.02	3.37	B43541E2827M0*#
820	30 × 40	100	32	140	6.27	3.73	B43541F2827M0*#
820	35 × 35	100	34	150	6.38	3.80	B43541G2827M0*#
1000	30 × 45	80	26	120	7.19	4.28	B43541E2108M0*#
1000	35 × 35	85	30	120	7.05	4.19	B43541F2108M0*#
1200	30 × 55	65	22	95	8.27	4.94	B43541E2128M0*#
1200	35 × 40	70	26	100	7.98	4.75	B43541F2128M0*#
1500	35 × 50	55	19	80	9.43	5.62	B43541E2158M0*#
1800	35 × 55	45	17	70	10.6	6.34	B43541E2188M0*#

Composition of ordering code

* = Insulation feature

0 = PVC insulation

6 = PET insulation

8 = PVC insulation with additional PET insulation cap on terminal side

= Terminal style

0 = snap-in standard terminals (6.3 mm)

2 = snap-in 3 terminals (4.5 mm)

7 = snap-in short terminals (4.5 mm)

Technical data and ordering codes

C_R	Case dimensions	ESR_{typ} 100 Hz 20 °C	ESR_{typ} 300 Hz 60 °C	Z_{max} 10 kHz 20 °C	$I_{AC,max}$ 100 Hz 60 °C	$I_{AC,R}$ 100 Hz 85 °C	Ordering code (composition see below)
μF	d × l mm	m Ω	m Ω	m Ω	A	A	
$V_R = 400 V DC$							
100	25 × 25	800	240	1200	1.74	0.98	B43541A9107M0*#
120	25 × 30	660	190	920	1.98	1.11	B43541A9127M0*#
150	25 × 35	530	150	740	2.30	1.30	B43541A9157M0*#
150	30 × 25	530	150	730	2.43	1.36	B43541B9157M0*#
180	25 × 35	440	130	620	2.58	1.45	B43541A9187M0*#
180	30 × 30	440	120	610	2.75	1.54	B43541B9187M0*#
180	35 × 25	440	130	620	2.88	1.62	B43541C9187M0*#
220	25 × 40	360	110	510	2.98	1.67	B43541A9227M0*#
220	30 × 30	370	100	530	3.15	1.77	B43541B9227M0*#
220	35 × 30	360	100	500	3.35	1.97	B43541C9227M0*#
270	25 × 45	300	90	440	3.48	1.96	B43541A9277M0*#
270	30 × 35	290	85	410	3.57	2.01	B43541B9277M0*#
270	35 × 30	300	85	410	3.78	2.22	B43541C9277M0*#
330	25 × 55	240	70	340	4.04	2.27	B43541A9337M0*#
330	30 × 40	240	70	340	4.20	2.46	B43541B9337M0*#
330	35 × 35	240	70	340	4.32	2.54	B43541C9337M0*#
390	30 × 45	200	60	290	4.73	2.78	B43541A9397M0*#
390	35 × 35	210	60	310	4.84	2.84	B43541B9397M0*#
470	30 × 50	170	50	250	5.46	3.21	B43541A9477M0*#
470	35 × 40	170	50	240	5.42	3.18	B43541B9477M0*#
560	35 × 50	140	40	200	6.17	3.63	B43541A9567M0*#
680	35 × 55	120	36	170	7.05	4.15	B43541A9687M0*#

Composition of ordering code

* = Insulation feature

0 = PVC insulation

6 = PET insulation

8 = PVC insulation with additional PET insulation cap on terminal side

= Terminal style

0 = snap-in standard terminals (6.3 mm)

2 = snap-in 3 terminals (4.5 mm)

7 = snap-in short terminals (4.5 mm)

B43541
Outstanding ripple current, high voltage – 85 °C
Technical data and ordering codes

C_R	Case dimensions	ESR_{typ} 100 Hz 20 °C	ESR_{typ} 300 Hz 60 °C	Z_{max} 10 kHz 20 °C	$I_{AC,max}$ 100 Hz 60 °C	$I_{AC,R}$ 100 Hz 85 °C	Ordering code (composition see below)
μF	mm	m Ω	m Ω	m Ω	A	A	
$V_R = 450$ V DC							
68	25 × 25	1600	400	2300	1.35	0.76	B43541A5686M0*#
82	25 × 30	1300	330	2000	1.53	0.86	B43541A5826M0*#
100	25 × 30	1100	270	1600	1.74	0.98	B43541A5107M0*#
100	30 × 25	1000	270	1600	1.86	1.05	B43541B5107M0*#
120	25 × 35	880	230	1400	1.97	1.11	B43541A5127M0*#
120	30 × 30	880	220	1300	2.09	1.18	B43541B5127M0*#
150	25 × 35	710	180	1100	2.27	1.28	B43541A5157M0*#
150	30 × 30	700	180	1100	2.41	1.35	B43541B5157M0*#
150	35 × 25	700	180	1100	2.53	1.42	B43541C5157M0*#
180	25 × 45	590	150	880	2.61	1.47	B43541A5187M0*#
180	30 × 35	580	150	870	2.72	1.53	B43541B5187M0*#
180	35 × 30	590	150	880	2.91	1.71	B43541C5187M0*#
220	25 × 50	480	120	720	3.02	1.70	B43541A5227M0*#
220	30 × 40	480	120	710	3.18	1.87	B43541B5227M0*#
220	35 × 30	480	120	720	3.28	1.93	B43541C5227M0*#
270	25 × 55	390	100	590	3.51	1.97	B43541A5277M0*#
270	30 × 40	390	100	590	3.63	2.14	B43541B5277M0*#
270	35 × 35	390	100	590	3.75	2.20	B43541C5277M0*#
330	30 × 50	320	80	480	4.21	2.48	B43541A5337M0*#
330	35 × 40	320	85	480	4.29	2.52	B43541B5337M0*#
390	30 × 55	270	70	410	4.76	2.80	B43541A5397M0*#
390	35 × 45	270	70	410	4.80	2.82	B43541B5397M0*#
470	35 × 50	230	60	340	5.45	3.21	B43541A5477M0*#
560	35 × 55	190	50	290	6.16	3.62	B43541A5567M0*#

Composition of ordering code

* = Insulation feature

0 = PVC insulation

6 = PET insulation

8 = PVC insulation with additional PET insulation cap on terminal side

= Terminal style

0 = snap-in standard terminals (6.3 mm)

2 = snap-in 3 terminals (4.5 mm)

7 = snap-in short terminals (4.5 mm)

Technical data and ordering codes

C_R	Case dimensions	ESR_{typ} 100 Hz 20 °C	ESR_{typ} 300 Hz 60 °C	Z_{max} 10 kHz 20 °C	$I_{AC,max}$ 100 Hz 60 °C	$I_{AC,R}$ 100 Hz 85 °C	Ordering code (composition see below)
μF	d × l mm	m Ω	m Ω	m Ω	A	A	
$V_R = 500 V DC$							
68	25 × 25	1400	370	2000	1.39	0.70	B43541A6686M0*#
82	25 × 30	1100	300	1700	1.58	0.80	B43541A6826M0*#
100	25 × 30	920	250	1400	1.78	0.90	B43541A6107M0*#
100	30 × 25	920	240	1400	1.91	0.96	B43541B6107M0*#
120	25 × 35	770	210	1200	2.03	1.02	B43541A6127M0*#
120	30 × 30	760	200	1200	2.16	1.09	B43541B6127M0*#
150	25 × 40	620	170	910	2.38	1.20	B43541A6157M0*#
150	30 × 30	610	160	910	2.47	1.25	B43541B6157M0*#
150	35 × 25	620	170	910	2.59	1.30	B43541C6157M0*#
180	25 × 45	510	140	760	2.71	1.37	B43541A6187M0*#
180	30 × 35	510	140	760	2.81	1.42	B43541B6187M0*#
180	35 × 30	510	140	760	2.97	1.56	B43541C6187M0*#
220	25 × 55	420	120	630	3.17	1.60	B43541A6227M0*#
220	30 × 40	420	110	620	3.27	1.72	B43541B6227M0*#
220	35 × 35	420	110	620	3.39	1.78	B43541C6227M0*#
270	30 × 45	340	90	510	3.78	1.99	B43541A6277M0*#
270	35 × 35	340	95	510	3.84	2.02	B43541B6277M0*#
330	30 × 55	280	75	420	4.38	2.31	B43541A6337M0*#
330	35 × 40	280	80	420	4.40	2.31	B43541B6337M0*#
390	35 × 45	240	65	360	4.93	2.60	B43541A6397M0*#
470	35 × 55	200	55	300	5.65	2.98	B43541A6477M0*#

Composition of ordering code

* = Insulation feature

0 = PVC insulation

6 = PET insulation

8 = PVC insulation with additional PET insulation cap on terminal side

= Terminal style

0 = snap-in standard terminals (6.3 mm)

2 = snap-in 3 terminals (4.5 mm)

7 = snap-in short terminals (4.5 mm)

B43541
Outstanding ripple current, high voltage – 85 °C
Technical data and ordering codes

C_R	Case dimensions	ESR_{typ} 100 Hz 20 °C	ESR_{typ} 300 Hz 60 °C	Z_{max} 10 kHz 20 °C	$I_{AC,max}$ 100 Hz 60 °C	$I_{AC,R}$ 100 Hz 85 °C	Ordering code (composition see below)
μF	mm	m Ω	m Ω	m Ω	A	A	
$V_R = 550$ V DC							
56	25 × 25	2370	560	3760	1.18	0.64	B43541A7566M0*#
68	25 × 30	1950	460	3100	1.36	0.73	B43541A7686M0*#
82	25 × 35	1620	380	2560	1.55	0.83	B43541A7826M0*#
82	30 × 25	1620	380	2560	1.63	0.87	B43541B7826M0*#
100	25 × 35	1330	320	2100	1.76	0.94	B43541A7107M0*#
100	30 × 30	1320	310	2100	1.86	1.00	B43541B7107M0*#
120	25 × 40	1110	260	1760	2.01	1.08	B43541A7127M0*#
120	30 × 35	1100	260	1750	2.10	1.13	B43541B7127M0*#
120	35 × 25	1150	280	1800	2.03	1.09	B43541C7127M0*#
150	25 × 50	890	210	1410	2.38	1.28	B43541A7157M0*#
150	30 × 35	880	210	1410	2.42	1.30	B43541B7157M0*#
150	35 × 30	890	210	1410	2.53	1.44	B43541C7157M0*#
180	25 × 55	740	180	1180	2.72	1.46	B43541A7187M0*#
180	30 × 40	740	170	1170	2.75	1.57	B43541B7187M0*#
180	35 × 35	740	180	1170	2.85	1.62	B43541C7187M0*#
220	30 × 50	600	140	960	3.19	1.82	B43541A7227M0*#
220	35 × 40	600	140	960	3.26	1.86	B43541B7227M0*#
270	30 × 55	490	120	780	3.69	2.11	B43541A7277M0*#
270	35 × 45	490	120	790	3.74	2.13	B43541B7277M0*#
330	35 × 50	400	100	640	4.29	2.44	B43541A7337M0*#
390	35 × 55	340	80	550	4.83	2.75	B43541A7397M0*#

Composition of ordering code

* = Insulation feature

0 = PVC insulation

6 = PET insulation

8 = PVC insulation with additional PET insulation cap on terminal side

= Terminal style

0 = snap-in standard terminals (6.3 mm)

2 = snap-in 3 terminals (4.5 mm)

7 = snap-in short terminals (4.5 mm)

Technical data and ordering codes

C_R	Case dimensions	ESR_{typ} 100 Hz 20 °C	ESR_{typ} 300 Hz 60 °C	Z_{max} 10 kHz 20 °C	$I_{AC,max}$ 100 Hz 60 °C	$I_{AC,R}$ 100 Hz 85 °C	Ordering code (composition see below)
μF	mm	m Ω	m Ω	m Ω	A	A	
$V_R = 600 V DC$							
47	25 × 25	2470	600	3840	0.99	0.60	B43541B8476M0*#
56	25 × 30	2070	500	3220	1.18	0.67	B43541B8566M0*#
68	25 × 35	1700	410	2660	1.43	0.77	B43541C8686M0*#
68	30 × 25	1700	410	2660	1.43	0.81	B43541D8686M0*#
82	25 × 35	1420	340	2200	1.62	0.87	B43541A8826M0*#
82	30 × 30	1410	340	2200	1.71	0.92	B43541B8826M0*#
100	25 × 40	1160	280	1810	1.87	1.00	B43541A8107M0*#
100	30 × 35	1160	280	1810	1.95	1.05	B43541B8107M0*#
100	35 × 25	1160	280	1810	2.04	1.09	B43541C8107M0*#
120	25 × 50	970	230	1510	2.15	1.16	B43541A8127M0*#
120	30 × 35	970	230	1510	2.20	1.18	B43541B8127M0*#
120	35 × 30	970	230	1510	2.30	1.30	B43541C8127M0*#
150	25 × 55	770	190	1210	2.53	1.36	B43541A8157M0*#
150	30 × 45	770	190	1210	2.57	1.47	B43541B8157M0*#
150	35 × 35	770	190	1210	2.66	1.51	B43541C8157M0*#
180	30 × 50	640	150	1010	2.93	1.67	B43541A8187M0*#
180	35 × 40	650	160	1010	3.00	1.71	B43541B8187M0*#
220	30 × 55	530	130	830	3.38	1.93	B43541A8227M0*#
220	35 × 45	530	130	830	3.43	1.95	B43541B8227M0*#
270	35 × 50	430	110	680	3.95	2.25	B43541A8277M0*#

Composition of ordering code

* = Insulation feature

0 = PVC insulation

6 = PET insulation

8 = PVC insulation with additional PET insulation cap on terminal side

= Terminal style

0 = snap-in standard terminals (6.3 mm)

2 = snap-in 3 terminals (4.5 mm)

7 = snap-in short terminals (4.5 mm)



B43541

Outstanding ripple current, high voltage – 85 °C

Useful life¹⁾

For useful life calculations, please use our web-based "AlCap Useful Life Calculation Tool", which can be found on the Internet under the following link

http://www.epcos.com/designtools/alu_useful_life/Useful_life.swf.

The AlCap Useful Life Calculation Tool provides calculations of useful life as well as additional data for selected capacitor types under operating conditions defined by the user.

Frequency characteristics of ESR

Typical behavior

$V_R \leq 500$ V DC

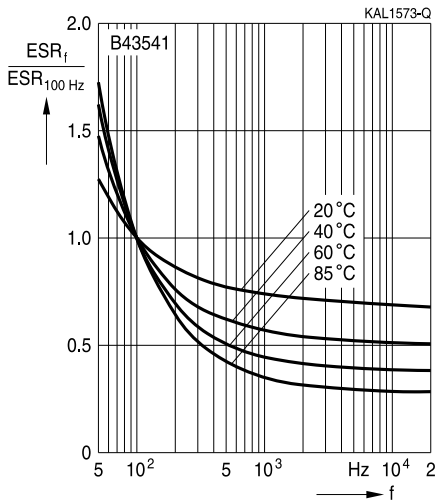

Impedance Z versus frequency f

Typical behavior at 20 °C

$V_R \leq 500$ V DC

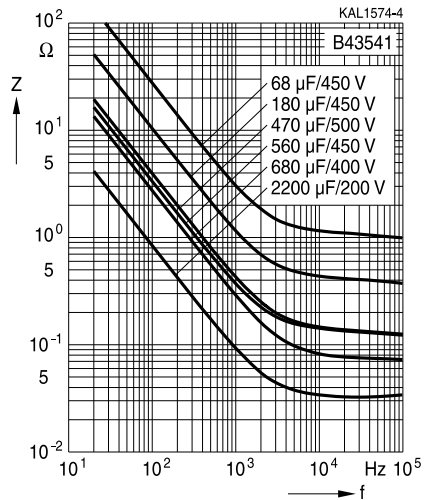

1) Refer to chapter "General technical information, 5 Useful life" on how to interpret useful life.



Frequency characteristics of ESR

Typical behavior

$V_R \geq 550$ V DC

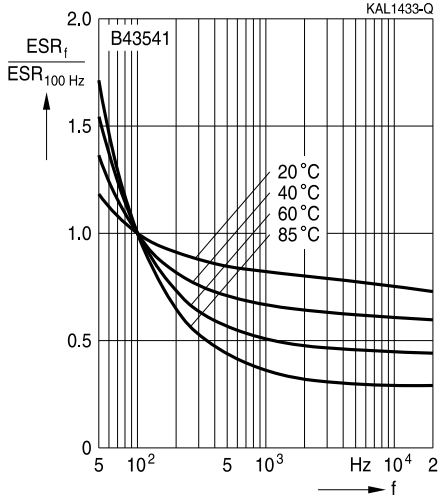

Impedance Z versus frequency f

Typical behavior at 20 °C

$V_R \geq 550$ V DC

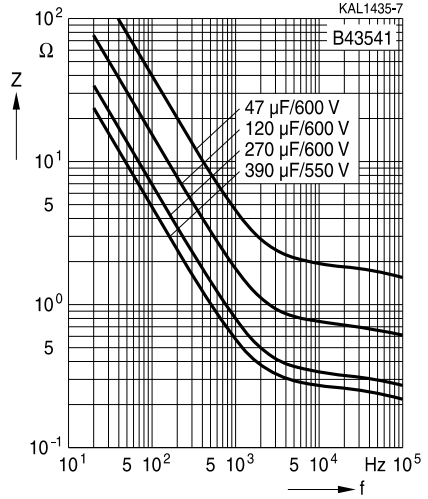



B43541

Outstanding ripple current, high voltage – 85 °C

Cautions and warnings

Personal safety

The electrolytes used by EPCOS have been optimized both with a view to the intended application and with regard to health and environmental compatibility. They do not contain any solvents that are detrimental to health, e.g. dimethyl formamide (DMF) or dimethyl acetamide (DMAC).

Furthermore, some of the high-voltage electrolytes used by EPCOS are self-extinguishing.

As far as possible, EPCOS does not use any dangerous chemicals or compounds to produce operating electrolytes. However, in exceptional cases, such materials must be used in order to achieve specific physical and electrical properties because no alternative materials are currently known. However, the amount of dangerous materials used in our products is limited to an absolute minimum.

Materials and chemicals used in EPCOS aluminum electrolytic capacitors are continuously adapted in compliance with the EPCOS Corporate Environmental Policy and the latest EU regulations and guidelines such as RoHS, REACH/SVHC, GADSL, and ELV.

MDS (Material Data Sheets) are available on the EPCOS website for all types listed in the data book. MDS for customer specific capacitors are available upon request.

MSDS (Material Safety Data Sheets) are available for all of our electrolytes upon request.

Nevertheless, the following rules should be observed when handling aluminum electrolytic capacitors: No electrolyte should come into contact with eyes or skin. If electrolyte does come into contact with the skin, wash the affected areas immediately with running water. If the eyes are affected, rinse them for 10 minutes with plenty of water. If symptoms persist, seek medical treatment. Avoid inhaling electrolyte vapor or mists. Workplaces and other affected areas should be well ventilated. Clothing that has been contaminated by electrolyte must be changed and rinsed in water.



Product safety

The table below summarizes the safety instructions that must be observed without fail. A detailed description can be found in the relevant sections of chapter "General technical information".

Topic	Safety information	Reference chapter "General technical information"
Polarity	Make sure that polar capacitors are connected with the right polarity.	1 "Basic construction of aluminum electrolytic capacitors"
Reverse voltage	Voltages of opposite polarity should be prevented by connecting a diode.	3.1.6 "Reverse voltage"
Mounting position of screw-terminal capacitors	Screw terminal capacitors must not be mounted with terminals facing down unless otherwise specified.	11.1. "Mounting positions of capacitors with screw terminals"
Robustness of terminals	The following maximum tightening torques must not be exceeded when connecting screw terminals: M5: 2.5 Nm M6: 4.0 Nm	11.3 "Mounting torques"
Mounting of single-ended capacitors	The internal structure of single-ended capacitors might be damaged if excessive force is applied to the lead wires. Avoid any compressive, tensile or flexural stress. Do not move the capacitor after soldering to PC board. Do not pick up the PC board by the soldered capacitor. Do not insert the capacitor on the PC board with a hole space different to the lead space specified.	11.4 "Mounting considerations for single-ended capacitors"
Soldering	Do not exceed the specified time or temperature limits during soldering.	11.5 "Soldering"
Soldering, cleaning agents	Do not allow halogenated hydrocarbons to come into contact with aluminum electrolytic capacitors.	11.6 "Cleaning agents"
Upper category temperature	Do not exceed the upper category temperature.	7.2 "Maximum permissible operating temperature"
Passive flammability	Avoid external energy, e.g. fire.	8.1 "Passive flammability"



B43541

Outstanding ripple current, high voltage – 85 °C

Topic	Safety information	Reference chapter "General technical information"
Active flammability	Avoid overload of the capacitors.	8.2 "Active flammability"
Maintenance	Make periodic inspections of the capacitors. Before the inspection, make sure that the power supply is turned off and carefully discharge the electricity of the capacitors. Do not apply excessive mechanical stress to the capacitor terminals when mounting.	10 "Maintenance"
Storage	Do not store capacitors at high temperatures or high humidity. Capacitors should be stored at +5 to +35 °C and a relative humidity of ≤ 75%.	7.3 "Shelf life and storage conditions"
		Reference chapter "Capacitors with screw terminals"
Breakdown strength of insulating sleeves	Do not damage the insulating sleeve, especially when ring clips are used for mounting.	"Screw terminals – accessories"

Display of ordering codes for EPCOS products

The ordering code for one and the same product can be represented differently in data sheets, data books, other publications and the website of EPCOS, or in order-related documents such as shipping notes, order confirmations and product labels. The varying representations of the ordering codes are due to different processes employed and do not affect the specifications of the respective products. Detailed information can be found on the Internet under www.epcos.com/orderingcodes.

Symbols and terms

Symbol	English	German
C	Capacitance	Kapazität
C_R	Rated capacitance	Nennkapazität
C_S	Series capacitance	Serienkapazität
$C_{S,T}$	Series capacitance at temperature T	Serienkapazität bei Temperatur T
C_f	Capacitance at frequency f	Kapazität bei Frequenz f
d	Case diameter, nominal dimension	Gehäusedurchmesser, Nennmaß
d_{max}	Maximum case diameter	Maximaler Gehäusedurchmesser
ESL	Self-inductance	Eigeninduktivität
ESR	Equivalent series resistance	Ersatzserienwiderstand
ESR_f	Equivalent series resistance at frequency f	Ersatzserienwiderstand bei Frequenz f
ESR_T	Equivalent series resistance at temperature T	Ersatzserienwiderstand bei Temperatur T
f	Frequency	Frequenz
I	Current	Strom
I_{AC}	Alternating current (ripple current)	Wechselstrom
$I_{AC,RMS}$	Root-mean-square value of alternating current	Wechselstrom, Effektivwert
$I_{AC,f}$	Ripple current at frequency f	Wechselstrom bei Frequenz f
$I_{AC,max}$	Maximum permissible ripple current	Maximal zulässiger Wechselstrom
$I_{AC,R}$	Rated ripple current	Nennwechselstrom
I_{leak}	Leakage current	Reststrom
$I_{leak,op}$	Operating leakage current	Betriebsreststrom
l	Case length, nominal dimension	Gehäuselänge, Nennmaß
l_{max}	Maximum case length (without terminals and mounting stud)	Maximale Gehäuselänge (ohne Anschlüsse und Gewindebolzen)
R	Resistance	Widerstand
R_{ins}	Insulation resistance	Isolationswiderstand
R_{symm}	Balancing resistance	Symmetrierwiderstand
T	Temperature	Temperatur
ΔT	Temperature difference	Temperaturdifferenz
T_A	Ambient temperature	Umgebungstemperatur
T_C	Case temperature	Gehäusetemperatur
T_B	Capacitor base temperature	Temperatur des Gehäusebodens
t	Time	Zeit
Δt	Period	Zeitraum
t_b	Service life (operating hours)	Brauchbarkeitsdauer (Betriebszeit)



B43541

Outstanding ripple current, high voltage – 85 °C

Symbol	English	German
V	Voltage	Spannung
V _F	Forming voltage	Formierspannung
V _{op}	Operating voltage	Betriebsspannung
V _R	Rated voltage, DC voltage	Nennspannung, Gleichspannung
V _S	Surge voltage	Spitzenspannung
X _C	Capacitive reactance	Kapazitiver Blindwiderstand
X _L	Inductive reactance	Induktiver Blindwiderstand
Z	Impedance	Scheinwiderstand
Z _T	Impedance at temperature T	Scheinwiderstand bei Temperatur T
tan δ	Dissipation factor	Verlustfaktor
λ	Failure rate	Ausfallrate
ε ₀	Absolute permittivity	Elektrische Feldkonstante
ε _r	Relative permittivity	Dielektrizitätszahl
ω	Angular velocity; $2 \cdot \pi \cdot f$	Kreisfrequenz; $2 \cdot \pi \cdot f$

Note

All dimensions are given in mm.

Important notes

The following applies to all products named in this publication:

1. Some parts of this publication contain **statements about the suitability of our products for certain areas of application**. These statements are based on our knowledge of typical requirements that are often placed on our products in the areas of application concerned. We nevertheless expressly point out **that such statements cannot be regarded as binding statements about the suitability of our products for a particular customer application**. As a rule, EPCOS is either unfamiliar with individual customer applications or less familiar with them than the customers themselves. For these reasons, it is always ultimately incumbent on the customer to check and decide whether an EPCOS product with the properties described in the product specification is suitable for use in a particular customer application.
2. We also point out that **in individual cases, a malfunction of electronic components or failure before the end of their usual service life cannot be completely ruled out in the current state of the art, even if they are operated as specified**. In customer applications requiring a very high level of operational safety and especially in customer applications in which the malfunction or failure of an electronic component could endanger human life or health (e.g. in accident prevention or lifesaving systems), it must therefore be ensured by means of suitable design of the customer application or other action taken by the customer (e.g. installation of protective circuitry or redundancy) that no injury or damage is sustained by third parties in the event of malfunction or failure of an electronic component.
3. **The warnings, cautions and product-specific notes must be observed.**
4. In order to satisfy certain technical requirements, **some of the products described in this publication may contain substances subject to restrictions in certain jurisdictions (e.g. because they are classed as hazardous)**. Useful information on this will be found in our Material Data Sheets on the Internet (www.epcos.com/material). Should you have any more detailed questions, please contact our sales offices.
5. We constantly strive to improve our products. Consequently, **the products described in this publication may change from time to time**. The same is true of the corresponding product specifications. Please check therefore to what extent product descriptions and specifications contained in this publication are still applicable before or when you place an order. We also **reserve the right to discontinue production and delivery of products**. Consequently, we cannot guarantee that all products named in this publication will always be available. The aforementioned does not apply in the case of individual agreements deviating from the foregoing for customer-specific products.
6. Unless otherwise agreed in individual contracts, **all orders are subject to the current version of the "General Terms of Delivery for Products and Services in the Electrical Industry" published by the German Electrical and Electronics Industry Association (ZVEI)**.

Important notes

7. The trade names EPCOS, Alu-X, CeraDiode, CeraLink, CeraPad, CeraPlas, CSMP, CSSP, CTVS, DeltaCap, DigiSiMic, DSSP, ExoCore, FilterCap, FormFit, LeaXield, MiniBlue, MiniCell, MKD, MKK, MotorCap, PCC, PhaseCap, PhaseCube, PhaseMod, PhiCap, PQSine, SIFERRIT, SIFI, SIKOREL, SilverCap, SIMDAD, SiMic, SIMID, SineFormer, SIOV, SIP5D, SIP5K, TFAP, ThermoFuse, WindCap are **trademarks registered or pending** in Europe and in other countries. Further information will be found on the Internet at www.epcos.com/trademarks.