

LIBERATOR CL10K50E

Key Features



- ◆ Fully Compatible To The Altera® FLEX® 10KE Family
- ◆ Prototype Your System With Altera FPGAs
- ◆ Seamlessly Migrate Production To Clear Logic
- ◆ No ASIC Engineering, No NRE, And No Test Vector Development
- ◆ Very Fast, Dense Signal Routing Using Vertical Link Interconnect
- ◆ "Gate Array" Option Eliminates Configuration EPROMs
- ◆ Fabricated Using 0.25 Micron CMOS Process
- ◆ Very Low Power Consumption (Active And Standby)
- ◆ High Density
 - 50,000 Usable Gates
 - 2,880 Logic Elements
 - 40,960 RAM Bits
 - 254 Maximum User I/O Pins

CL10KE Product Family Overview

Parameter	CL10K30E	CL10K50E CL10K50S	CL10K100E	CL10K200E CL10K200S
Typical Gates (Logic and RAM)	30,000	50,000	100,000	200,000
Maximum System Gates	119,000	199,000	257,000	513,000
Logic Elements	1,728	2,880	4,992	9,984
Embedded Array Blocks	6	10	12	24
Total RAM Bits	24,576	40,960	49,152	98,304
Max User I/O pins	220	254	338	470
Speed Grades	-1, -2, -3	-1, -2, -3	-1, -2, -3	-1, -2, -3
Packages	144-pin TQFP 208-pin PQFP 256-pin FBGA 484-pin FBGA	144-pin TQFP 208-pin PQFP 240-pin PQFP 256-pin FBGA 356-pin SBGA 484-pin FBGA	208-pin PQFP 240-pin PQFP 256-pin FBGA 356-pin SBGA 484-pin FBGA	240-pin PQFP 356-pin SBGA 484-pin FBGA 600-pin SBGA 672-pin FBGA

10KE tbl 01

Description

The LIBERATOR™ CL10KE family offers you all of the time-to-market benefits of designing with programmable logic. Simply use Altera FLEX 10KE FPGAs to prototype and verify the design. Then, take five minutes to submit the bitstream using Clear Logic's web site! Within eight weeks, your system can be in volume production using compatible Clear Logic devices.

LIBERATOR technology frees you to completely design, prototype, and verify your custom logic using Altera FLEX 10KE products. Clear Logic's innovative technology eliminates NRE costs, test vector development, ordering minimums, and long lead times. No re-simulation or re-layout is required, because Clear Logic offers an architecture that is exactly compatible to the functionality of the FPGA prototype. Clear Logic's NoFault® test technology ensures complete test coverage through the use of special scan test registers.

The LIBERATOR family is based upon an array of logic elements. Each logic element contains a configurable look-up table for combinatorial functions and a register for sequential operations. Eight logic elements in a group form a block. Logic functions and signal routing are defined by Clear Logic's proprietary vertical metal links.

Laser-based configuration allows quick-turn prototyping and eliminates NRE costs for photomasks. Inherent CL10KE family performance benefits include extremely consistent propagation delays, reduced power consumption, and improved immunity to noise and upset events.

Configuration

The "Gate Array" configuration mode eliminates the need for external EPROMs or software configuration. The LIBERATOR device is already factory-configured when it is shipped. When using the device in the "Gate Array" mode, it powers up fully configured. In this mode, if the customer selects INIT_DONE option, this pin will always be high.

**Additional
Information**

For further information on designing with the LIBERATOR family, please refer to these documents:

- ◆ AN-01: Requesting a First Article. This document provides instructions on how to request first articles by submitting a bitstream file to Clear Logic's web site.
- ◆ AN-02: Clear Logic Packaging Guide. This document provides specifications and drawings for packages used by the CL10K family and other Clear Logic devices.
- ◆ AN-13: LIBERATOR -- A New Way To Design. This document describes the most efficient path for custom logic designs up to 200K gates using FPGA design techniques and going to production with Clear Logic.
- ◆ AN-14: CL10K Technology White Paper. This document outlines the technologies employed by the LIBERATOR family.
- ◆ AN-15: LIBERATOR System Configuration. This document contains a detailed discussion of all aspects of configuring CL10K-based systems.
- ◆ AN-16: Introduction to the Clear Logic Verilog Model Generator. Clear Logic now has Verilog models of your FPGA converted design. Learn what it is and how it can help you.
- ◆ AN-17: Clear Logic LIBERATOR Design Models. This document outlines the capabilities and freedom available in the Clear Logic Verilog and VHDL design models.
- ◆ AN-18: Debugging Designs Using Clear Logic Models. This document shows the enhanced troubleshooting capabilities that the Clear Logic LIBERATOR Verilog/VHDL design models bring to the system debugging process.

Block Diagram

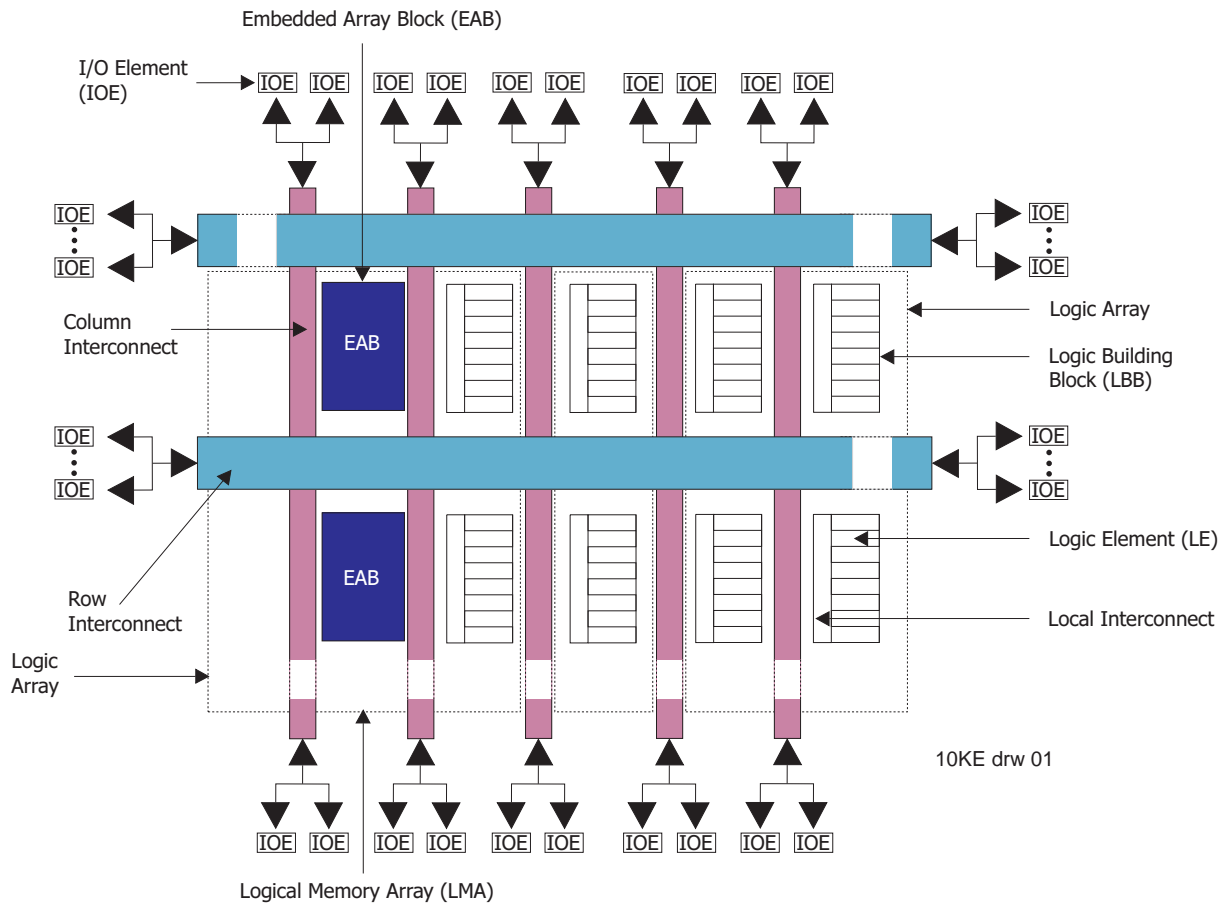

Pin Configuration

Pin Name	144-Pin TQFP	208-Pin PQFP	240-Pin PQFP
MSEL0	77	108	124
MSEL1	76	107	123
nSTATUS	35	52	60
nCONFIG	74	105	121
DCLK	107	155	179
CONF_DONE	2	2	2
INIT_DONE	14	19	26
nCE	106	154	178
nCEO	3	3	3
nWS	142	206	238
nRS	141	204	236
nCS	144	208	240
CS	143	207	239
RDYnBSY	11	16	23
CLKUSR	7	10	11
DATA7	116	166	190
DATA6	114	164	188
DATA5	113	162	186
DATA4	112	161	185
DATA3	111	159	183
DATA2	110	158	182
DATA1	109	157	181
DATA0	108	156	180

10K50E tbl 01A

Pin Configuration

Pin Name	144-Pin TQFP	208-Pin PQFP	240-Pin PQFP
TDI	105	153	177
TDO	4	4	4
TCK	1	1	1
TMS	34	50	58
TRST		51	59
Dedicated Inputs	54, 56, 124, 126	78, 80, 182, 184	90, 92, 210, 212
Dedicated Clock Pins	55, 125	79, 183	91, 211
DEV_CLRn	122	180	209
DEV_OE	128	186	213
VCCINT	6, 25, 52, 53, 75, 93, 123	6, 23, 35, 43, 76, 106, 109, 117, 137, 145, 181	5, 27, 47, 96, 122, 130, 150, 170
VCCIO	5, 24, 45, 61, 71, 94, 115, 134	5, 22, 34, 42, 66, 84, 98, 110, 118, 138, 146, 165, 178, 194	16, 37, 57, 77, 112, 140, 160, 189, 205, 224
VCC_CCLK	53	77	89
GNDINT	15, 16, 40, 50, 58, 66, 84, 85, 103, 104, 127, 129, 139	20, 21, 32, 33, 48, 49, 59, 72, 82, 91, 123, 124, 129, 130, 151, 152, 171, 185, 188, 201	10, 22, 32, 42, 52, 69, 85, 93, 104, 125, 135, 145, 155, 165, 176, 197, 216, 232
GND_CCLK	57	81	93
No Connect	-	-	-
Total user I/O Pins	102	147	189

10K50E tbl 01B

Pin Configuration

Pin Name	256-Pin FBGA	356-Pin SBGA	484-Pin FBGA
MSEL0	P1	D4	U4
MSEL1	R1	D3	V4
nSTATUS	T16	D24	W19
nCONFIG	N4	D2	T7
DCLK	B2	AC5	E5
CONF_DONE	C15	AC24	F18
INIT_DONE	G16	T24	K19
nCE	B1	AC2	E4
nCEO	B16	AC22	E19
nWS	B14	AE24	E17
nRS	C14	AE23	F17
nCS	A16	AD24	D19
CS	A15	AD23	D18
RDYnBSY	G14	U22	K17
CLKUSR	D15	AA24	G18
DATA7	B5	AF4	E8
DATA6	D4	AD8	G7
DATA5	A4	AE5	D7
DATA4	B4	AD6	E7
DATA3	C3	AF2	F6
DATA2	A2	AD5	D5
DATA1	B3	AD4	E6
DATA0	A1	AD3	D4
TDI	C2	AC3	F5
TDO	C16	AC23	F19
TCK	B15	AD25	E18
TMS	P15	D22	U18
TRST	R16	D23	V19
Dedicated Inputs	B9, E8, M9, R9	A13, B14, AF14, AE13	E12, H11, R12, V11
Dedicated Clock Pins	A9, L8	A14, AF13	D12, P11

10K50E tbl 01C

Pin Configuration

Pin Name	256-Pin FBGA	356-Pin SBGA	484-Pin FBGA
DEV_CLRn	D8	AD13	G11
DEV_OE	C9	AE14	F12
VCCINT	E11, F5, F7, F9, F12, H6, H7, H10, J7, J10, J11, K9, L5, L7, L12, M11, R2	A1, A26, C26, D5, F1, H22, J1, M26, N1, T26, U5, AA1, AD26, AF1, AF26	C11, C15, H14, J8, J10, J12, J15, L9, L10, L13, M10, M13, M14, N12, P8, P10, P15, R14, V5, W21, Y8, AA12
VCCIO	D12, E6, F8, F10, G6, G8, G11, H11, J6, K6, K8, K11, L10, M6, N12	A7, A23, B3, C15, D25, F4, H24, K5, M23, P2, T25, V2, W22, AB1, AC25, AD18M, AF3, AF7, AF16	A6, A13, B5, E1, G1, G15, H9, H20, J11, J13, K9, K11, K14, K20, L14, M9, N3, N9, N11, N14, N20, P13, R1, R9, T3, T15, T22, V22, AB13
VCC_CKCLK	L9	C14	P12
GND	E5, E12, F6, F11, G7, G9, G10, H8, H9, J8, J9, K7, K10, L6, L11, M5, M12	A2, A10, A20, B1, B22, B25, B26, C2, C9, C13, C25, H23, J26, K1, M1, N26, R1, R26, T1, U26, W1, AD2, AD14, AD20, AE1, AE2, AE7, AE25, AE26, AF11, AF19, AF25	A1, A8, A22, B1, B2, B17, B21, B22, C2, C21, E21, G3, G21, H2, H8, H15, J9, J14, J20, K3, K10, K12, K13, L11, L12, M11, M12, M20, N10, N13, P9, P14, R8, R15, R22, T1, V3, W20, Y1, Y2, Y3, Y21, Y22, AA1, AA6, AA22, AB11, AB16
GND_CKCLK	T8	B13	W11
No Connect	-	D1, E2, E22, E25, F5, F23, F26, G3, G22, G25, H4, H5, J2, J4, J23, J24, K2, K3, K25, K26, L2, L23, L26, M2, M5, M22, M25, N4, N25, P1, P5, P22, P23, R5, T22, U2, U3, U23, U24, V4, W3, W4, W24, W26, Y2, Y5, AA3, AA22, AA25, AB3, AB5, AB22, AB24, AB26	A2, A3, A4, A5, A7, A9, A11, A12, A14, A15, A20, A21, B3, B4, B9, B10, B12, B16, B19, B20, C1, C6, C9, C10, C12, C13, C14, C16, C17, C22, D1, D2, D3, D20, D21, E2, E3, E20, E22, F1, F2, F20, F21, G2, G20, G22, J1, J2, J3, J21, K1, K2, K22, L1, L2, L20, L22, M2, M3, M22, N1, N2, N21, N22, P3, P20, P21, P22, R2, R3, R21, T2, T20, T21, U1, U2, U3, U20, U21, U22, V2, V20, W1, W2, W22, Y4, Y9, Y12, Y13, Y16, Y19, Y20, AA2, AA3, AA4, AA9, AA11, AA13, AA15, AA21, AB1, AB2, AB3, AB4, AB5, AB7, AB8, AB9, AB12, AB15, AB17, AB18, AB19, AB20, AB21, AB22
Total user I/O Pins	191	220	254

10K50E tbi 01D

DC Electrical Specifications

Absolute Maximum Ratings

Symbol	Parameter	Conditions	Min	Max	Unit
V _{CC}	Supply Voltage		-0.5	3.6	V
V _I	DC Input Voltage ^[1]		-2.0	5.75	V
I _{OUT}	DC Output Current, per Pin		-25	25	mA
T _{STG}	Storage Temperature	No Bias	-65	150	°C
T _{AMB}	Ambient Temperature	Under Bias	-65	135	°C
T _J	Junction Temperature	Under Bias		135	°C

10KE tbl 02

Recommended Operating Conditions ^[2]

Symbol	Parameter	Conditions	Min	Max	Unit
V _{CCINT}	Supply Voltage, Internal Logic and Input Buffers	Commercial Grade Devices	2.30	2.70	V
		Industrial Grade Devices	2.30	2.70	V
V _{CCIO}	DC Input Voltage for 3.3V Operation	Commercial Grade Devices	3.00	3.60	V
		Industrial Grade Devices	3.00	3.60	V
V _{CCIO}	DC Input Voltage for 2.5V Operation	Commercial Grade Devices	2.30	2.70	V
		Industrial Grade Devices	2.30	2.70	V
V _I	Input Voltage		-0.5	5.75	V
V _O	Output Voltage		0	V _{CCIO}	V
T _A	Operating Temperature	Commercial Temperature Range	0	70	°C
		Industrial Temperature Range	-40	85	°C
t _R	Input Signal Rise Time			40	ns
t _F	Input Signal Fall Time			40	ns

10KE tbl 03A

DC Electrical Specifications cont.

DC Electrical Characteristics (over the operating range)

Symbol	Parameter	Conditions	Min	Typ ^[3]	Max	Unit
V _{IH}	Input HIGH Voltage		Lower of 1.7 or 0.5 x V _{CCINT}		5.75	V
V _{IL}	Input LOW Voltage		-0.5		0.3 x V _{CCIO}	V
V _{OH}	3.3-V High-Level TTL Output Voltage	I _{OH} = -8 mA DC, V _{CCIO} = 3.00 V	2.4			V
	3.3-V High-Level CMOS Output Voltage	I _{OH} = -0.1 mA DC, V _{CCIO} = 3.00 V	V _{CCIO} -0.2			V
	3.3-V High-Level PCI Output Voltage	I _{OH} = -0.5 mA DC, V _{CCIO} = 3 to 3.60 V	0.9 x V _{CCIO}			V
		I _{OH} = -0.1 mA DC, V _{CCIO} = 2.30 V	2.1			V
	2.5-V High-Level Output Voltage	I _{OH} = -1 mA DC, V _{CCIO} = 2.30 V	2.0			V
		I _{OH} = -2 mA DC, V _{CCIO} = 2.30 V	1.7			V
V _{OL}	3.3-V Low-Level TTL Output Voltage	I _{OL} = 9 mA DC, V _{CCIO} = 3.00 V			0.45	V
	3.3-V Low-Level CMOS Output Voltage	I _{OL} = 0.1 mA DC, V _{CCIO} = 3.00 V			0.2	V
	3.3-V Low-Level PCI Output Voltage	I _{OL} = 1.5 mA DC, V _{CCIO} = 3 to 3.60 V			0.1 x V _{CCIO}	V
		I _{OL} = 0.1 mA DC, V _{CCIO} = 2.30 V			0.2	V
	2.5-V Low-Level Output Voltage	I _{OL} = 1 mA DC, V _{CCIO} = 2.30 V			0.4	V
		I _{OL} = 2 mA DC, V _{CCIO} = 2.30 V			0.7	V
I _{IN}	Input Leakage Current	V _I = 5.3V to -0.3V	-10		10	μA
I _{OZ}	Output Leakage Current	V _O = 5.3V to -0.3V	-10		10	μA
I _{CC0}	Standby Current	V _I = GND, No Load		5		mA

10KE tbl 04

Capacitance^[4]

Symbol	Parameter	Conditions	Min	Max	Unit
C _{IN}	Input Capacitance	V _{IN} = 0 V, f = 1.0 MHz		10	pF
C _{OUT}	Output Capacitance	V _{OUT} = 0 V, f = 1.0 MHz		10	pF

10KE tbl 05

AC Electrical Specifications

I/O Element Timing Parameters ^[5]

Symbol	Parameter	Speed: -1		Speed: -2		Speed: -3		Unit
		Min	Max	Min	Max	Min	Max	
t _{IOD}	IOE Register Data Delay		2.4		2.8		3.8	ns
t _{IOC}	IOE Register Control Signal Delay		0.3		0.3		0.5	ns
t _{IOCO}	IOE Register Clock to Output Delay		0.2		0.2		0.3	ns
t _{IOCOMB}	IOE Combinatorial Delay		0.5		0.6		0.8	ns
t _{IOSU}	IOE Register Setup Time Before Clock	2.2		2.6		3.5		ns
t _{IOH}	IOE Register Hold Time After Clock	0.5		0.6		0.8		ns
t _{IOCLR}	IOE Register Clear Delay		0.2		0.2		0.3	ns
t _{OD1}	Output Buffer and Pad Delay Slow Slew Rate = off, VCCIO = V _{CCINT}		1.1		1.3		1.8	ns
t _{OD2}	Output Buffer and Pad Delay Slow Slew Rate = off, VCCIO = Low Voltage		0.6		0.9		1.6	ns
t _{OD3}	Output Buffer and Pad Delay Slow Slew Rate = on		3.0		3.5		4.8	ns
t _{ZX}	Output Buffer Disable Delay ^[6]		1.1		1.3		1.8	ns
t _{ZX1}	Output Buffer Disable Delay Slow Slew Rate = off, VCCIO = V _{CCINT} ^[6]		1.1		1.3		1.6	ns
t _{ZX2}	Output Buffer Disable Delay Slow Slew Rate = off, VCCIO = Low Voltage ^[6]		0.6		0.9		1.6	ns
t _{ZX3}	Output Buffer Disable Delay Slow Slew Rate = on ^[6]		3.0		3.5		4.8	ns
t _{INREG}	IOE Input Pad and Buffer to IOE Register Delay		5.0		5.9		8.0	ns
t _{IOFD}	IOE Register Feedback Delay		3.0		3.6		4.8	ns
t _{INCOMB}	IOE Input Pad and Buffer to Interconnect Delay		3.0		3.6		4.8	ns

10KE tbl 06A

AC Electrical Specifications cont.

External Timing Parameters^[4]

Symbol	Parameter	Speed: -1		Speed: -2		Speed: -3		Unit
		Min	Max	Min	Max	Min	Max	
t_{DRR}	Register to Register Delay via Four LEs, Three Row Interconnects, and Four Local Interconnects		8.5		10.0		13.5	ns
t_{INSU}	Setup Time with Global Clock at IOE Register	3.0		3.6		4.8		ns
t_{INH}	Hold time with Global Clock at IOE Register	0.0		0.0		0.0		ns
t_{OUTCO}	Output Data Hold Time After Clock	2.0	4.6	2.0	5.4	2.0	8.0	ns

10KE tBI 07B

Logic Element Timing Parameters^[5]

Symbol	Parameter	Speed: -1		Speed: -2		Speed: -3		Unit
		Min	Max	Min	Max	Min	Max	
t_{LUT}	Look-up Table Delay for Data-in		0.6		0.8		1.1	ns
t_{CLUT}	Look-up Table Delay for Carry-in		0.5		0.6		0.8	ns
t_{RLUT}	Look-up Table Delay for LE Register Feedback		0.7		0.8		1.1	ns
t_{PACKED}	Data-in to Packed Register Delay		0.5		0.6		0.8	ns
t_{EN}	LE Register Enable Delay		0.6		0.7		0.9	ns
t_{CICO}	Carry-in to Carry-out Delay		0.2		0.2		0.3	ns
t_{CGEN}	Data-in to Carry-out Delay		0.5		0.5		0.8	ns
t_{CGENR}	LE Register Feedback to Carry-out Delay		0.2		0.2		0.3	ns
t_{CASC}	Cascade Chain Routing Delay		0.8		0.9		1.2	ns
t_c	LE Register Control Signal Delay		0.5		0.6		0.8	ns
t_{CO}	LE Register Clock-to-output Delay		0.5		0.6		0.7	ns
t_{COMB}	Combinatorial Delay		0.5		0.6		0.7	ns
t_{SU}	LE Register Setup Time Before Clock	0.5		0.6		0.8		ns
t_H	LE Register Hold Time After Clock	0.9		1.1		1.5		ns
t_{PRE}	LE Register Preset Delay		0.5		0.6		0.8	ns
t_{CLR}	LE Register Clear Delay		0.5		0.6		0.8	ns
t_{CH}	Clock High Time	2.0		2.5		3.0		ns
t_{CL}	Clock Low Time	2.0		2.5		3.0		ns

10KE tBI 08A

AC Electrical Specifications cont.

Interconnect Timing Parameters^[5]

Symbol	Parameter	Speed: -1		Speed: -2		Speed: -3		Unit
		Min	Max	Min	Max	Min	Max	
$t_{DIN2IOE}$	Delay from Dedicated Input Pin to IOE Control Input		4.6		5.1		6.4	ns
t_{DIN2LE}	Delay from Dedicated Input Pin to LE or EAB Control Input		0.9		1.0		1.3	ns
$t_{DIN2DATA}$	Delay from Dedicated Input or Clock Pin to LE or EAB Data		1.5		1.9		2.3	ns
$t_{DCLK2IOE}$	Delay from Dedicated Clock Pin to IOE Clock		3.9		4.6		6.2	ns
$t_{DCLK2LE}$	Delay from Dedicated Clock Pin to LE or EAB Clock		0.9		1.0		1.3	ns
$t_{SAMELAB}$	Delay from an LE to LE in Same LAB		0.1		0.1		0.2	ns
$t_{SAMEROW}$	Delay for Driving a Row IOE, LE or EAB to a Row IOE, LE or EAB in the Same Row		1.3		1.3		1.8	ns
$t_{SAMECOLUMN}$	Delay from an LE to IOE in the Same Column		1.6		1.7		2.4	ns
$t_{DIFFROW}$	Delay for Driving a Column IOE, LE or EAB to an LE or EAB in a Different Row		2.9		3.0		4.2	ns
$t_{TROWROWS}$	Delay for Driving a Row IOE or EAB to an LE or EAB in a Different Row		4.2		4.3		6.0	ns
$t_{LEPERIPH}$	Delay from an LE to IOE Control Signal via the Peripheral Control Bus		4.3		4.6		5.8	ns
$t_{LABCARRY}$	Delay from an LE Carry-out Signal to an LE Carry-in Signal in a Different LAB		0.1		0.1		0.2	ns
$t_{LABCASC}$	Delay from an LE Cascade-out Signal to an LE Cascade-in Signal in a Different LAB		0.3		0.3		0.5	ns

10KE tbl 09B

AC Electrical Specifications cont.**EAB Timing Parameters^[5]**

Symbol	Parameter	Speed: -1		Speed: -2		Speed: -3		Unit
		Min	Max	Min	Max	Min	Max	
$t_{EABDATA1}$	Delay from Data or Address to EAB for Combinatorial Input		1.7		2.0		2.7	ns
$t_{EABDATA2}$	Delay from Data or Address to EAB for Registered Input		0.6		0.7		0.9	ns
t_{EABWE1}	WE Delay to EAB for Combinatorial Input		1.1		1.3		1.8	ns
t_{EABWE2}	WE Delay to EAB for Registered Input		0.4		0.4		0.6	ns
t_{EABCLK}	EAB Register Clock Delay		0.0		0.0		0.0	ns
t_{EABCO}	EAB Register Clock-to-output Delay		0.3		0.3		0.5	ns
$t_{EABYPASS}$	Bypass Register Delay		0.5		0.6		0.8	ns
t_{EABSU}	EAB Register Setup Time	0.9		1.0		1.4		ns
t_{EABH}	EAB Register Hold Time	0.4		0.4		0.6		ns
t_{AA}	Address Access Delay		3.2		3.8		5.1	ns
t_{WP}	Write Pulse Width	2.5		2.9		3.9		ns
t_{WDSU}	Data Setup Time Before Falling Edge of Write Pulse	0.9		1.0		1.4		ns
t_{WDH}	Data Hold Time After Falling Edge of Write Pulse	0.1		0.1		0.2		ns
t_{WASU}	Address Setup Time Before Rising Edge of Write Pulse	1.7		2.0		2.7		ns
t_{WAH}	Address Hold After Falling Edge of Write Pulse	1.8		2.1		2.9		ns
t_{WO}	Write Enable to Date Output Delay		2.5		2.9		3.9	ns
t_{DD}	Data-in to Date-out Delay		2.5		2.9		3.9	ns
t_{EABOUT}	Data-out Delay		0.5		0.6		0.8	ns
t_{EABCH}	Clock High Time	1.5		2.0		2.5		ns
t_{EABCL}	Clock Low Time	1.5		2.0		2.5		ns

10KE tbl 10A

AC Electrical Specifications cont.

EAB Timing Parameters^[5]

Symbol	Parameter	Speed: -1		Speed: -2		Speed: -3		Unit
		Min	Max	Min	Max	Min	Max	
t _{EABAA}	EAB Address Access Delay		6.4		7.6		10.2	ns
t _{EABRCCOMB}	EAB Asynchronous Read Cycle Time	6.4		7.6		10.2		ns
t _{EABRCREG}	EAB Synchronous Read Cycle Time	4.4		5.1		7.0		ns
t _{EABWP}	EAB Write Pulse Width	2.5		2.9		3.9		ns
t _{EABWCCOMB}	EAB Asynchronous Write Cycle Time	6.0		7.0		9.5		ns
t _{EABWCREG}	EAB Synchronous Write Cycle Time	6.8		7.8		10.6		ns
t _{EABDD}	EAB Data-in to Data-out Delay		5.7		6.7		9.0	ns
t _{EABDATACO}	EAB Clock-to-output Delay Using Output Registers		0.8		0.9		1.3	ns
t _{EABDATASU}	EAB Data/Address Setup Time Using Input Register	1.5		1.7		2.3		ns
t _{EABDATAH}	EAB Data/Address Hold Time Using Input Register	0.0		0.0		0.0		ns
t _{EABWESU}	EAB WE Setup When Using Input Register	1.3		1.4		2.0		ns
t _{EABWESH}	EAB WE Hold Time When Using Input Register	0.0		0.0		0.0		ns
t _{EABWDSU}	EAB Data Setup Time to Falling Edge of Write Pulse When Not Using Input Registers	1.5		1.7		2.3		ns
t _{EABWDH}	EAB Data Hold Time After Falling Edge of Write Pulse When Not Using Input Registers	0.0		0.0		0.0		ns
t _{EABWASU}	EAB Address Setup Time to Rising Edge of Write Pulse When Not Using Input Registers	3.0		3.6		4.8		ns
t _{EABWAH}	EAB Address Hold Time After Falling Edge of Write Pulse When Not Using Input Registers	0.5		0.5		0.8		ns
t _{EABWO}	EAB WE to Data Output Delay		5.1		6.0		8.1	ns

10KE tbl 11A

AC Electrical Specifications cont.

External Bidirectional Timing Parameters^[5]

Symbol	Parameter	Speed: -1		Speed: -2		Speed: -3		Unit
		Min	Max	Min	Max	Min	Max	
$t_{INSUBIDIR}$	Setup for Bi-directional Pins with Global Clock at Adjacent LE Registers	2.7		3.4		4.8		ns
$t_{INHIDIR}$	Hold Time for Bi-directional Pins with Global Clock at Adjacent LE Registers	0.0		0.0		0.0		ns
$t_{OUTCOBIDIR}$	Clock-to-output Delay for Bi-directional Pins with Global Clock at IOE Register	2.0	4.6	2.0	5.4	2.0	8.2	ns
$t_{XZBIDIR}$	Synchronous IOE Output Buffer Disable Delay	2.0	6.3	2.0	6.8	2.0	8.5	ns
$t_{ZXBIDIR}$	Synchronous IOE Output Buffer Disable Delay, Slow Slew Rate = off	2.0	5.2	2.0	5.8	2.0	7.7	ns

10KE tbl 12B

AC Test Conditions

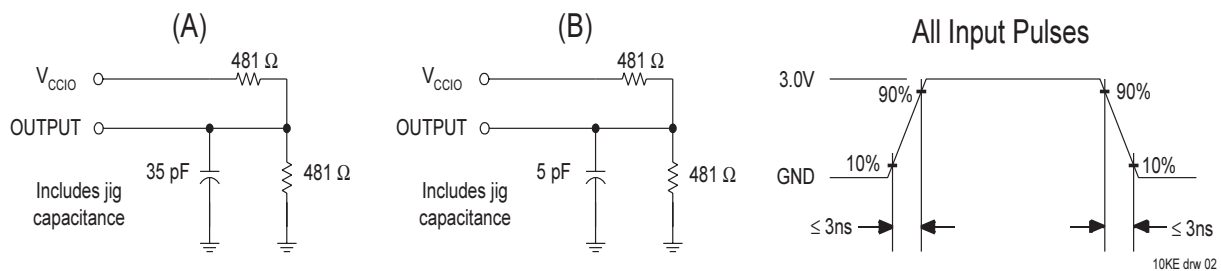

A: Test fixture set-up A is for general testing.
 B: Test fixture set-up B is for high Z testing ($t_{ZX\#}$).

Notes to Tables

1. During transitions, inputs may undershoot to -2.0V or overshoot to 5.75V for periods shorter than 20ns. Otherwise, minimum DC input voltage is -0.5V.
2. Device inputs may be driven before V_{CCINT} and V_{CCIO} are powered.
3. Typical values are at V_{CC} of 3.3 volts and ambient temperature of 25 °C.
4. Guaranteed but not tested. Characterized initially, and after any design changes which may affect these parameters.
5. Internal timing delays are based on characterization, and cannot be explicitly tested. Internal timing parameters should be used for performance estimation only.
6. Use AC Test Conditions set-up B for these parameters.

Revision History

- 02 Dec. 2000: Created new document
- 22 May 2001: Corrected VCCINT table

Ordering Information

Part Number	Temperature Range	Package Type	Speed	Altera Equivalent
CL10K30ETC144-3	Commercial	144-pin TQFP	-3	EPF10K30ETC144-3
CL10K30ETC144-2			-2	EPF10K30ETC144-2
CL10K30ETC144-2X*			-2	EPF10K30ETC144-2X
CL10K30ETC144-1			-1	EPF10K30ETC144-1
CL10K30ETC144-1X*			-1	EPF10K30ETC144-1X
CL10K30EQC208-3	Commercial	208-pin Plastic QFP	-3	EPF10K30EQC208-3
CL10K30EQC208-2			-2	EPF10K30EQC208-2
CL10K30EQC208-2X*			-2	EPF10K30EQC208-2X
CL10K30EQC208-1			-1	EPF10K30EQC208-1
CL10K30EQC208-1X*			-1	EPF10K30EQC208-1X
CL10K30EQI208-2	Industrial		-3	EPF10K30EQI208-2
CL10K30EFC256-3	Commercial	256-pin FBGA	-3	EPF10K30EFC256-3
CL10K30EFC256-2			-2	EPF10K30EFC256-2
CL10K30EFC256-2X*			-2	EPF10K30EFC256-2X
CL10K30EFC256-1			-1	EPF10K30EFC256-1
CL10K30EFC256-1X*			-1	EPF10K30EFC256-1X
CL10K30EFI256-2	Industrial		-3	EPF10K30EFI256-2
CL10K50EFC484-3	Commercial	484-pin SBGA	-3	EPF10K30EFC484-3
CL10K50EFC484-2		Use CL10K50EFC484 [†]	-2	EPF10K30EFC484-2
CL10K50EFC484-2X*			-2	EPF10K30EFC484-2X
CL10K50EFC484-1			-1	EPF10K30EFC484-1
CL10K50EFC484-1X*			-1	EPF10K30EFC484-1X

10K30E tbl 02

[†] The 484-pin FBGA is not offered for the CL10K30E. Use the CL10K50E. This can be done by locking the I/Os in MAX+PLUS[®] II and recompiling to a CL10K50E. Test the part on your board with an Altera FLEX[®] EPF10K50E and then submit the bitstream to Clear Logic for production product.

* Contact your local Clear Logic Representative for availability.

