

CR Series with Cree SmartCast® Technology

CR22™ 2' x 2' Architectural LED Troffer with Cree SmartCast® Technology

Product Description

The CR22™ architectural LED troffer with Cree SmartCast® Technology, Cree's intelligent light solution, provides extreme energy productivity and code compliance - all with installation that's so intuitive and simple, it just works. Cree SmartCast® Technology products incorporate integrated ambient and occupancy sensing and wireless communication to achieve energy savings and extended product life resulting in lower electricity bills, reduced maintenance, and an improved total cost of ownership over traditional lighting control systems. And now, CR Series troffers with Cree SmartCast® Technology offer field adjustable color temperatures, simplifying project specification, ordering and installation by allowing one troffer to be used in any space regardless of color temperature preference.

Performance Summary

Utilizes Cree TrueWhite® Technology
Room-Side Heat Sink
Efficacy: 100 LPW
Initial Delivered Lumens: 3,200 lumens
Input Power: 32 watts
CRI: 90 CRI
CCT: 3000K, 3500K, 4000K, 5000K, adjustable CCT
Input Voltage: 120-277 VAC
Limited Warranty*: 5 years
Controls: Cree SmartCast® Technology
Mounting: Recessed*

* See <http://lighting.cree.com/warranty> for warranty terms

Accessories

Field-Installed	
Drywall Grid Adapter DGA-24WH	Cree SmartCast® Technology Face Plates**
Cree SmartCast® Technology Configuration Tool† CCT-CWC-1 - One required per project when CMA control is selected	CFP-1-WH - Matching Cree face plate, 1-gang, white
	CFP-2-WH - Matching Cree face plate, 2-gang, white
	CFP-3-WH - Matching Cree face plate, 3-gang, white
	Cree SmartCast® Technology Wireless Dimmer**
	CWD-CWC-WH
	Cree SmartCast® Technology Wireless Switch**
	CWS-CWC-WH

† Refer to the [Configuration Tool spec sheet](#) for more details

** Refer to the [Wireless Dimmer Smartcast Control spec sheet](#) for more details

Ordering Information

Example: CR22-32L-35K-CMA

Product	Initial Delivered Lumens	CCT	Voltage	Control	Options
CR22	32L 32W, 3,200 lumens - 100 LPW	30K 3000K 35K 3500K 40K 4000K 50K 5000K ACK Adjustable CCT: 3000K-5000K - Factory set at 4000K - Adjustable in 500K increments	Blank 120-277 Volt	CMA Cree SmartCast® Technology - Integral motion and ambient sensors and wireless communication	EB10W Emergency Battery Backup - 32L-ACK: 1,000 lumens

* Acceptable for use with standard 9/16 T-Bar or larger when installed per installation instructions. Consult factory for non-standard grid applications

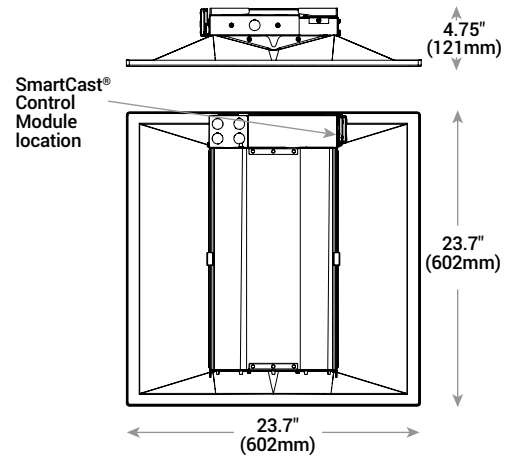

Rev. Date: V5 02/03/2016

US: lighting.cree.com/lighting

T (800) 236-6800 F (262) 504-5415

Canada: www.cree.com/canada



T (800) 473-1234 F (800) 890-7507

Product Specifications

CREE SMARTCAST® TECHNOLOGY

Cree SmartCast® Technology is the most intuitive and easiest to install intelligent light solution on the market. SmartCast Technology delivers up to 70% energy savings at up to half the cost of other solutions. Luminaires combine best-in-class light with onboard sensors and intelligence to deliver a better light experience. Extreme energy productivity, code compliance and a better light experience without any extra design, installation or setup work.

CREE TRUEWHITE® TECHNOLOGY

A revolutionary way to generate high-quality white light, Cree TrueWhite® Technology is a patented approach that delivers an exclusive combination of 90+ CRI, beautiful light characteristics, and lifelong color consistency, all while maintaining high luminous efficacy – a true no compromise solution.

ROOM-SIDE HEAT SINK

An innovative thermal management system designed to maximize cooling effectiveness by integrating a unique room-side heat sink into the diffusing lens. This breakthrough design creates a pleasing architectural aesthetic while conducting heat away from LEDs in a temperature-controlled environment. This enables the LEDs to consistently run cooler, providing significant boosts to lifetime, efficacy, and color consistency.

CONSTRUCTION & MATERIALS

- Durable 22-gauge steel housing with standard troffer access plate for electrical installation
- One-piece lower reflector finished with a textured high reflectance white polyester powder coating creates a comfortable visual transition from the lens to the ceiling plane
- Includes t-bar clips and holes for mounting support wires (by others)

OPTICAL SYSTEM

- Unique combination of reflective and refractive optical components achieves a uniform, comfortable appearance while eliminating pixelation and color fringing
- Components work together to optimize distribution, balancing the delivery of high illuminance levels on horizontal surfaces with an ideal amount of light on walls and vertical surfaces. This increases the perception of spaciousness
- Diffusing lens integrated with upward-facing LED strip eliminates direct view of LEDs while lower reflector balances brightness of lens with the ceiling to create a low-glare high angle appearance

ELECTRICAL SYSTEM

- Integral, high-efficiency driver
- **Power Factor:** = 0.9 nominal
- **Input Voltage:** 120-277V, 50/60Hz
- **Operating Temperature Range:** 0°C - + 35°C (32°F - + 95°F)
- **Total Harmonic Distortion:** < 20%
- **Dimming:** 5% - 100%

REGULATORY & VOLUNTARY QUALIFICATIONS

- cULus Listed
- Suitable for damp locations
- Designed for indoor use
- UL924 (EB10W option)
- DLC qualified. Please refer to www.designlights.org/QPL for most current information
- RoHS compliant. Consult factory for additional details
- Meets FCC Part 15 standards for conducted and radiated emissions

Cree SmartCast® Technology

INTEGRAL MOTION SENSOR

- Passive infrared (PIR)
- **Coverage area:** 100 sq. ft. (30.5m²) at 10 ft. (3.0m) mounting height
- Not intended to be mounted higher than 12 ft. (3.7m)
- **Operation:**
 - *Grouped with a wall control:* Luminaire will operate in vacancy mode (manual-on/auto-off)
 - *Not grouped with a wall control:* Luminare will operate in occupancy mode (auto-on/auto-off)
- Luminaires operate at full intensity until OneButton™ Setup is initiated by the Cree Configuration Tool

AMBIENT LIGHT SENSOR

- Sensor response matches response of human eye
- Not intended to be mounted higher than 12 ft. (3.7m)
- Luminaires operate at full intensity until OneButton™ Setup is initiated by the Cree Configuration Tool
- Daylight harvesting calibration performed automatically during OneButton™ Setup

INTEGRAL WIRELESS COMMUNICATION

- 2.4GHz wireless mesh technology with AES 128-bit encryption
- Self assigns to quietest channel during OneButton™ Setup
- **Range:**
 - 30 ft. (9.1m) in typical commercial applications
 - 300 ft. (91.4m) open air without obstructions
- **Network:** 250 devices max.
- **Space:** 100 devices max. per group
- FCC certified
- IC certified

LUMINAIRE

- Luminaires operate at full intensity until OneButton™ Setup is initiated by the Cree Configuration Tool
- 10 year power fail memory of settings

DEPLOYMENT

- Please refer to the SmartCast® Deployment Guide at www.creelink.com/exLink.asp?236135640H88E44I39771048

CR22™ 2' x 2' Architectural LED Troffer with Cree SmartCast® Technology

Photometry

CR22-32L-30K BASED ON CSA REPORT TEST #: 2362893-01

Luminaire photometry has been conducted by a NVLAP accredited testing laboratory in accordance with IESNA LM-79-08. IESNA LM-79-08 specifies the entire luminaire as the source resulting in a luminaire efficiency of 100%.

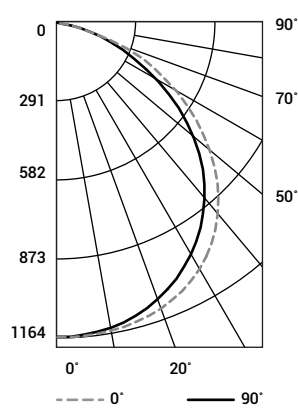

Coefficients Of Utilization – Zonal Cavity Method					
RC %:	80				
RW %:	70	50	30	10	
RCR: 0	119	119	119	119	
1	110	105	101	98	
2	100	92	86	80	
3	91	81	73	67	
4	84	72	63	57	
5	77	64	55	49	
6	71	58	49	43	
7	66	52	44	38	
8	61	48	39	33	
9	57	44	36	30	
10	53	40	32	27	

Effective Floor Cavity Reflectance: 20%

Average Luminance Table (cd/m ²)				
Vertical Angle	Horizontal Angle			
	0°	45°	90°	
45°	3,517	3,799	3,852	
55°	3,117	3,552	3,568	
65°	2,439	2,970	3,066	
75°	1,559	2,063	1,656	
85°	359	203	133	

Zonal Lumen Summary			
Zone	Lumens	% Lamp	Luminaire
0-30	925	N/A	28.2%
0-40	1,532	N/A	46.7%
0-60	2,716	N/A	82.7%
0-90	3,284	N/A	100%
0-180	3,284	N/A	100%

Reference www.cree.com/Lighting/Products/Indoor/Troffers/CR-Series for detailed photometric data

Application Reference

Based on CR22-32L-30K Luminaire

Open Space					
Spacing	Lumens	Wattage	LPW	w/ft ²	Average fc
8 x 8	3,200	32W	100	0.55	44
8 x 10				0.44	37
10 x 10				0.35	31
10 x 12				0.29	25

9' ceiling; 80/50/20 reflectances; 2.5' workplane, open room. LLF: 1.0 Initial Open Space: 50' x 40' x 10'

Recommended CR Series Lumen Maintenance Factors (LMF) ¹					
Ambient	Initial LMF	25K hr Projected ² LMF	50K hr Projected ² LMF	75K hr Calculated ³ LMF	100K hr Calculated ³ LMF
0°C (32°F)	1.05	1.04	1.04	1.04	1.04
5°C (41°F)	1.04	1.03	1.03	1.03	1.03
10°C (50°F)	1.03	1.02	1.02	1.02	1.02
15°C (59°F)	1.02	1.01	1.01	1.01	1.01
20°C (68°F)	1.01	1.00	1.00	1.00	1.00
25°C (77°F)	1.00	0.99	0.99	0.99	0.99
30°C (86°F)	0.99	0.98	0.98	0.98	0.98
35°C (95°F)	0.98	0.97	0.97	0.97	0.97
40°C (104°F)	0.97	0.96	0.96	0.96	0.96

¹ Lumen maintenance values at 25°C are calculated per TM-21 based on LM-80 data and in-situ luminaire testing

² In accordance with IESNA TM-21-11, Projected Values represent interpolated value based on time durations that are within six times (6x) the IESNA LM-80-08 total test duration (in hours) for the device under testing ((DUT) i.e. the packaged LED chip)

³ In accordance with IESNA TM-21-11, Calculated Values represent time durations that exceed six times (6x) the IESNA LM-80-08 total test duration (in hours) for the device under testing ((DUT) i.e. the packaged LED chip)

