



NPN BD675/A - BD677/A - BD679/A - BD681/A

SILICON DARLINGTON POWER TRANSISTORS

The BD675/A-BD677/A-BD679/A-BD681/A are NPN transistors mounted in Jedec TO-126 plastic package.

They are epitaxial-base transistors in monolithic Darlington circuit for audio and video applications.

PNP complements are BD676/A - BD678/A - BD680/A - BD682/A

Compliance to RoHS.

ABSOLUTE MAXIMUM RATINGS

Symbol	Ratings	Value	Unit	
V_{CEO}	Collector-Emitter Voltage	BD675/A	45	V
		BD677/A	60	
		BD679/A	80	
		BD681/A	100	
V_{CBO}	Collector-Base Voltage	BD675/A	45	V
		BD677/A	60	
		BD679/A	80	
		BD681/A	100	
V_{EBO}	Emitter-Base Voltage	5	V	
I_C	Collector Current	I_C	4	A
		I_{CM}	6	
I_B	Base current (peak value)	I_{BM}	0.1	A
P_T	Total power Dissipation	@ $T_{mb} = 25^\circ C$	40	W
T_J	Junction Temperature		150	$^\circ C$
T_{Stg}	Storage Temperature		-65 to +150	$^\circ C$

THERMAL CHARACTERISTICS

Symbol	Ratings	Value	Unit
R_{thJ-mb}	Thermal Resistance, Junction to mounting base	3.12	K/W
R_{thJ-a}	Thermal Resistance, Junction to ambient in free air	100	K/W

NPN BD675/A - BD677/A - BD679/A - BD681/A
ELECTRICAL CHARACTERISTICS

TC=25°C unless otherwise noted

Symbol	Ratings	Test Condition(s)	Min	Typ	Max	Unit	
I_{CBO}	Collector cut-off current	$I_E=0, V_{CB}=60\text{ V}$	BD675/A	-	-	0,2	mA
		$I_E=0, V_{CB}=80\text{ V}$	BD677/A	-	-	0,2	
		$I_E=0, V_{CB}=100\text{ V}$	BD679/A	-	-	0,2	
		$I_E=0, V_{CB}=120\text{ V}$	BD681/A	-	-	0,2	
		$I_E=0, V_{CB}=30\text{ V}, T_j=150^\circ\text{C}$	BD675/A	-	-	2	
		$I_E=0, V_{CB}=40\text{ V}, T_j=150^\circ\text{C}$	BD677/A	-	-	2	
		$I_E=0, V_{CB}=50\text{ V}, T_j=150^\circ\text{C}$	BD679/A	-	-	2	
		$I_E=0, V_{CB}=60\text{ V}, T_j=150^\circ\text{C}$	BD681/A	-	-	2	
I_{CEO}	Collector cut-off current	$I_B=0, V_{CE}=\frac{1}{2}V_{CEOMAX}$	BD675/A	-	-	0,5	mA
		$I_B=0, V_{CE}=\frac{1}{2}V_{CEOMAX}$	BD677/A	-	-	0,5	
		$I_B=0, V_{CE}=\frac{1}{2}V_{CEOMAX}$	BD679/A	-	-	0,5	
		$I_B=0, V_{CE}=\frac{1}{2}V_{CEOMAX}$	BD681/A	-	-	0,5	
I_{EBO}	Emitter cut-off current	$I_C=0, -V_{EB}=5\text{ V}$	-	-	5	mA	
$V_{CEO(SUS)}$	Collector-Emitter sustaining Voltage	$I_B=0, I_C=50\text{ mA}$	BD675/A	45	-	-	V
			BD677/A	60	-	-	
			BD679/A	80	-	-	
			BD681/A	100	-	-	
$V_{CE(SAT)}$	Collector-Emitter saturation Voltage	BD675, BD677, BD679, BD681 $I_C=1.5\text{ A}, I_B=30\text{ mA}$	-	-	2,5	V	
		BD675A, BD677A, BD679A, BD681A $I_C=2\text{ A}, I_B=40\text{ mA}$	-	-	2.8		
h_{FE}	DC Current Gain	BD675, BD677, BD679, BD681 $V_{CE}=3\text{ V}, I_C=500\text{ mA}$	-	2200	-		
		BD675, BD677, BD679, BD681 $V_{CE}=3\text{ V}, I_C=1,5\text{ A}$	750	-	-		
		BD675, BD677, BD679, BD681 $V_{CE}=3\text{ V}, I_C=4\text{ A}$	-	1500	-		
		BD675A, BD677A, BD679A, BD681A $V_{CE}=3\text{ V}, I_C=2\text{ A}$	750	-	-		
V_{BE}	Base-Emitter Voltage(1&2)	BD675, BD677, BD679, BD681 $V_{CE}=3\text{ V}, I_C=1,5\text{ A}$	-	-	2,5	V	
		BD675A, BD677A, BD679A, BD681A $V_{CE}=3\text{ V}, I_C=2\text{ A}$	-	-	2.5		
h_{fe}	Small signal current gain	$V_{CE}=3\text{ V}, I_C=1,5\text{ A}, f=1\text{ MHz}$	10	-	-		
f_{hfe}	Ut-off frequency	$V_{CE}=3\text{ V}, I_C=1,5\text{ A}$	-	60	-	kHz	
V_F	Diode forward voltage	$I_F=1,5\text{ A}$	-	1,5	-	V	
$I_{(SB)}$	Second-breakdown collector current	$-V_{CE}=50\text{ V}, t_p=20\text{ms, non rep., without heatsink}$	0,8	-	-	A	

NPN BD675/A - BD677/A - BD679/A - BD681/A

Symbol	Ratings	Test Condition(s)	Min	Typ	Max	Unit
t_{on}	Turn-on time	$-I_{con} = 1,5A, -I_{bon} = I_{boff} = 6mA,$	-	0,3	1.5	μs
t_{off}	Turn-off time		-	1,5	5	

1. Measured under pulse conditions : $t_p < 300\mu s, \square < 2\%$.
2. V_{BE} decreases by about 3,6 mV/K with increasing temperature.

MECHANICAL DATA CASE TO-126

	DIMENSIONS	
	min	max
A	7.4	7.8
B	10.5	10.8
C	2.4	2.7
D	0.7	0.9
E	2.25 typ.	
F	0.49	0.75
G	4.4 typ.	
L	15.7 typ.	
M	1.27 typ.	
N	3.75 typ.	
P	3.0	3.2
S	2.54 typ.	

Pin 1 :	Emitter
Pin 2 :	Collector
Pin 3 :	Base

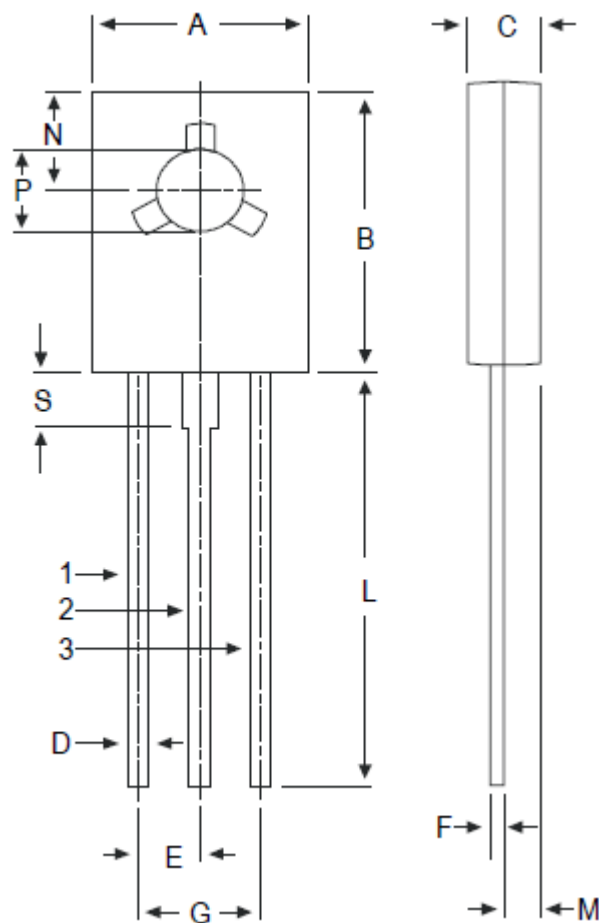

Revised August 2012

Information furnished is believed to be accurate and reliable. However, Comset Semiconductors assumes no responsibility for the consequences of use of such information nor for any infringement of patents or other rights of third parties which may result from its use. Data are subject to change without notice. Comset Semiconductors makes no warranty, representation or guarantee regarding the suitability of its products for any particular purpose, nor does Comset Semiconductors assume any liability arising out of the application or use of any product and specifically disclaims any and all liability, including without limitation consequential or incidental damages. Comset Semiconductors' products are not authorized for use as critical components in life support devices or systems.