

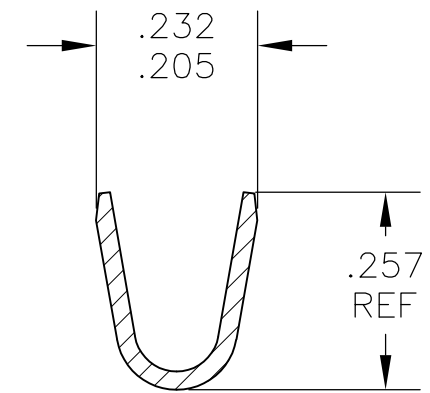

THIS DRAWING IS UNPUBLISHED. RELEASED FOR PUBLICATION  
 © COPYRIGHT - By - ALL RIGHTS RESERVED.

LOC	DIST	REVISIONS			
P	LTR	DESCRIPTION	DATE	DWN	APVD
AF	50	B	REVISED PER ECR-13-005733	22AUG2013	KH PD

- CONTINUOUS STRIP ON REELS
- WIRE SIZE 7,000 - 13,000 CMA
- CRIMP INFO: .180 WIDTH, F TYPE  
 CRIMP HT ( $\pm 0.002$ ) = (TOTAL CMA + 22,200)/304,500

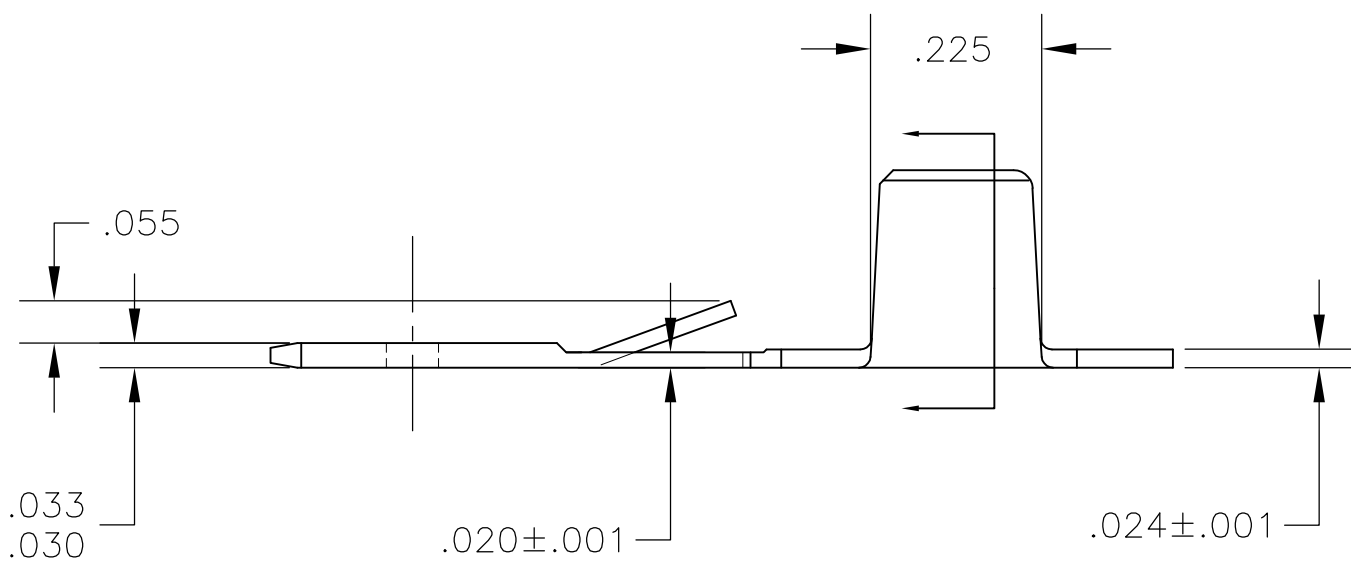
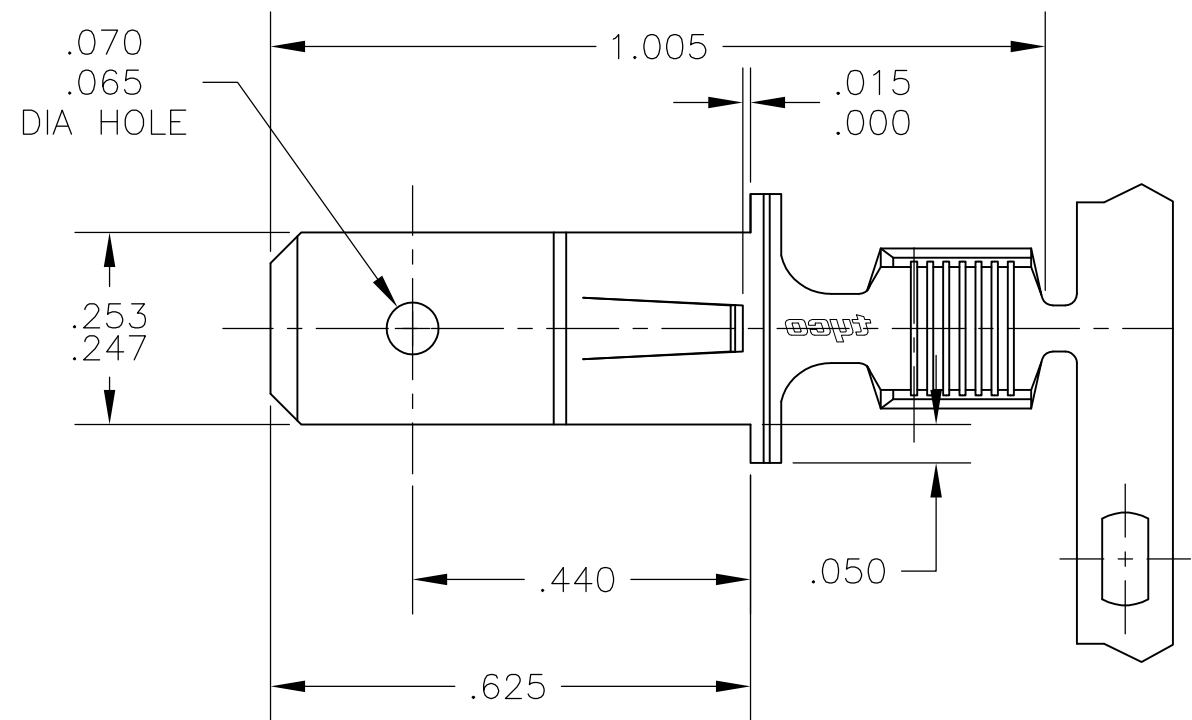

1742266-1  
 PART NO

THIS DRAWING IS A CONTROLLED DOCUMENT.		DWN jr_ruth 11APR05	 TE Connectivity		
DIMENSIONS: INCHES		CHK K RANDOLPH 11APR05			
TOLERANCES UNLESS OTHERWISE SPECIFIED:		APVD K RANDOLPH 11APR05	PRODUCT SPEC		
0 PLC ± - 1 PLC ± - 2 PLC ± - 3 PLC ± .010 4 PLC ± - ANGLES ± 5°		APPLICATION SPEC 114-2146		SIZE A3	CAGE CODE 00779
MATERIAL BRASS		FINISH .000080 MIN TIN		DRAWING NO C-1742266	
CUSTOMER DRAWING			WEIGHT -	RESTRICTED TO -	SCALE 4:1
			SHEET 1 OF 1		REV B