

This document is the property of Amphenol Corporation and is delivered on the express condition that it is not to be disclosed, reproduced or used in whole or in part for manufacture or sale by anyone other than Amphenol Corporation without its prior consent, and that no right is granted to disclose or to use any information in this document.

| REVISIONS | | | | |
|-----------|-----|---------------------|---------|----------|
| SYM | ECN | DESCRIPTION | DATE | APPROVED |
| A | EK# | PRELIMINARY RELEASE | 3/26/03 | Y.M.LEE |
| B | EK# | ADD CHOP OF ROHS | 8/2/06 | IP |

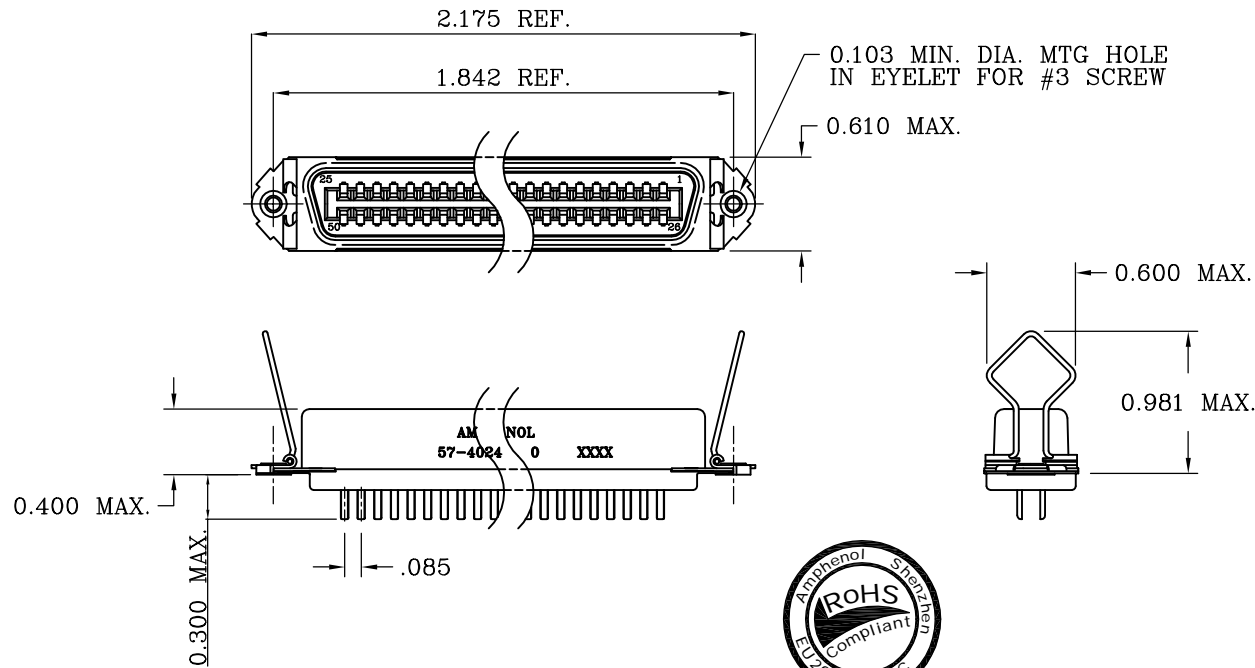

TABLE 1

| CONNECTOR SIZES | AVERAGE MATING FORCE (POUNDS) |
|-----------------|-------------------------------|
| 14 | 5 |
| 24 | 8 |
| 36 | 12 |
| 50 | 15 |
| 64 | 19 |

SPECIFICATIONS:

- 1) SOLDER CONTACT: SOLDER CUP CONTACT TO ACCOMMODATE 22-30 AWG SOLID & 24-30 STRANDED CONNECTOR WIRES.
- 2) DIELECTRIC: DIALLY-PHTHALATE PER MIL-M-14F TYPE MDG UL-94V0
- 3) CONTACT MATERIAL: COPPER ALLOY
- 4) CONTACT: 20 MICRO-INCHES MIN. GOLD MATING AREA, GOLD FLASH ON TAIL. 50 MICRO-INCHES MIN. NICKEL UNDERPLATING ALL OVER.
- 5) SHELL MATERIAL: ZINC PLATED STEEL WITH CLEAR CHROMATE COATING
- 6) CURRENT CAPACITY: 5 AMPS/CONTACT
- 7) VOLTAGE RATING: 700 VOLTS D.C. AT SEA LEVEL
200 VOLTS D.C. AT 70,000 FEET
- 8) INSULATION RESISTANCE: >5000 M OHM
- 9) DIELECTRIC WITHSTANDING VOLTAGE: 1200 VAC (RMS) AT SEA LEVEL
- 10) CONNECTOR MATING FORCE: REFER TO TABLE 1.

- 11) CONTACT RETENTION FORCE: 2 LBS MAX.
- 12) DURABILITY: 250 CYCLES MIN.
- 13) VIBRATION: NO INTERRUPTIONS < 1u SEC.
- 14) OPERATING TEMPERATURE: -55°C TO +105°C
(-67°F TO +221°F)
- 15) MATERIAL SHOULD FULFILLED AMPHENOL SPEC.# SSN001

CUSTOMER INFORMATION DRAWING

| ITEM NO | PART OR IDENTIFICATION NO | NOMENCLATURE OR DESCRIPTION | QTY REQ'D |
|---------------------------------------|---------------------------|---|-----------|
| PARTS LIST | | | |
| UNLESS OTHERWISE SPECIFIED TOLERANCES | | APPROVAL | DATE |
| .X +/- 0.20 | | DRAWN ES.GUO | 8/2/06 |
| .XX +/- 0.10 | | CHECKED | |
| .XXX +/- 0.05 | | CHECKED | |
| FRACTIONS +/- | | DRAWING FILE : /DRAWING/57/CS740240.DWG | |
| ANGLES +/- 1° | | TITLE | |
| FOR MATERIALS AND FINISHES SEE NOTES | | 24 CONTACT RECEPTACLE ASS'Y MINIATURE RIBBON, SPRING LATCH | |
| REMOVE SHARP EDGES | | SIZE DRAWING NO. | |
| DIMENSIONS | | A3 C57-40240 | |
| U.S. INCHES | | REV. B | |
| -(METRIC)- (MM)- | | SCALE NONE SHEET 1 OF 1 | |