

TOP VIEW -SHOW ORIENTATION OF LEGENDS  
IN RESPECT TO THE PCB PIN TERMINALS.

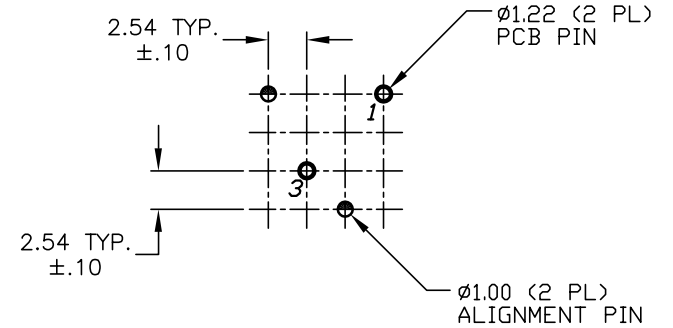

RECOMMENDED P.C.B. LAYOUT

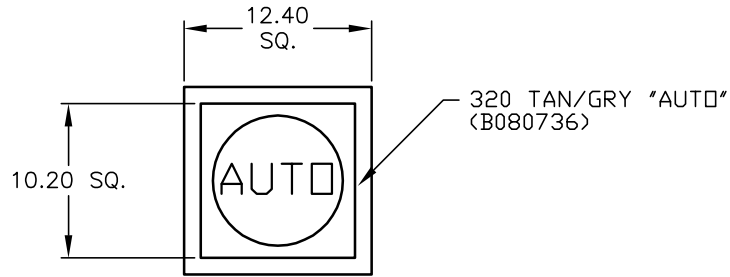
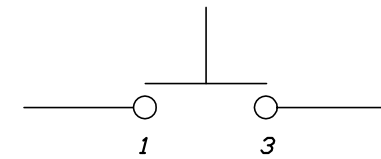
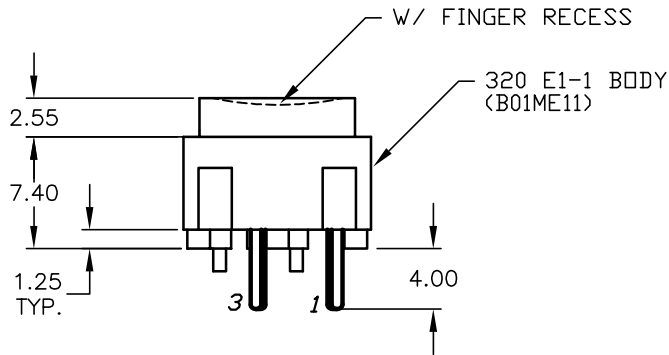

CIRCUIT: SPST  
CONTACT CONFIGURATION

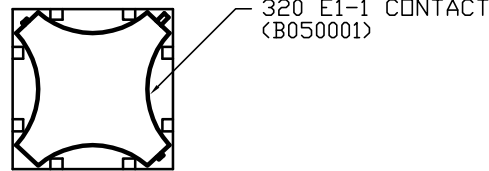
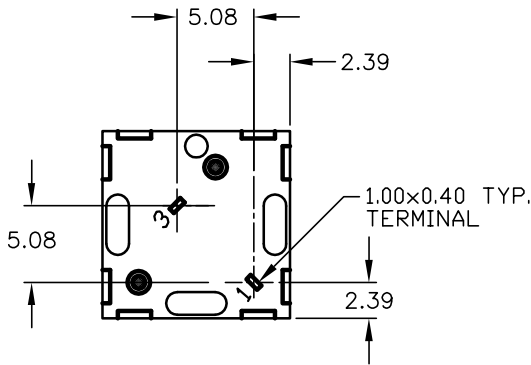

SHOWN CAP REMOVED

- NOTES:
1. ALL DIMINIONS IN MM
  2. GENERAL TOLERANCE: X.X=±0.4  
X.XX=±0.25
  3. TERMINAL NO'S FOR REFERENCE ONLY.
  4. RATING: 25mA, @50VDC
  5. OPERATING FORCE: 120gF
  6. TRAVEL TO MAKE: 0.7mm

**E-SWITCH®**

B	12655	REVISED NOTES	12/23/02	CJB
REV.	ECN No.	DESCRIPTION	DATE	CHKD

TITLE				
320 E1-1 TAN/GRY "AUTO"				
SCALE	DATE	DR	DWG	REV
2:1	12/14/00	CJB	XB0744A	B

THE INFORMATION CONTAINED IN THIS DOCUMENT  
IS PROPRIETARY TO E-SWITCH AND IS  
NOT TO BE COPIED OR TRANSFERRED