

Features

Reference Design

- Half-bridge voltage up to 1kV
- TTL-compatible signal input
- Single 15V to 42V supply
- Shoot-through protection
- Separate input for low and high-side switch for use with different topologies

R-REF01-HB

Description

The Half-Bridge Gate-Drive Power Supply Reference Design (RD) consists of a half-bridge suitable for voltages up to 1kV and a fully-isolated driver stage with isolated power supplies for the low-side and the high-side switching transistors. It is suitable for single gate drive supply voltages as low as +4V as well as dual gate drive supply voltages as high as +20V / -5V (30V max) with no maximum duty cycle limitations.

Two R12P22005D, R12P21053D, R12P21509D and R12P06S DC/DC modules each are included in the R-REF01-HB design kit.

NOTE: transistors sold separately.

The signal ground is galvanically isolated from the power ground and can be connected to any potential, as long as it is less than 2.5kV with respect to the power potential (high-side and low-side). The limiting element is the gate driver IC specification.

Features:

- Optimized for very high switching speed
- 2.5kV continuous input to output isolation
- High gate-drive currents (up to 10A source and sink)
- The RD is fitted with a SI8273 gate driver, but can be used with any pin-compatible gate driver with a PWM input (SI8274) or for gate driver ICs with reinforced isolation, for example the UCC21520 (dual pinout layout on PCB).

This RD can easily be configured for the following topologies (see application suggestions section):

- LLC half-bridge
- Asymmetric duty cycle half-bridge (forward and flyback)
- Active clamp half-bridge (forward and flyback)
- Full-bridge / phase-shifted full-bridge
- 3-phase B6 bridge
- NPC B6 bridge (additional driving circuit for NPC is required)
- Double pulse test
- Synchronous boost converter
- Synchronous buck converter



Delivered Board

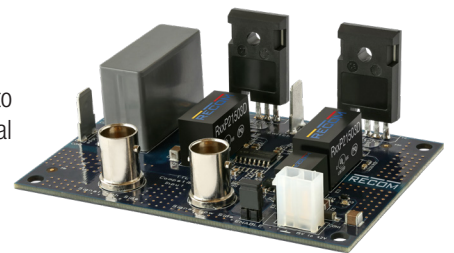

fully populated



DANGER!

This board is designed to be used with voltages up to 1kV, only qualified personnel should work with this board. Direct contact with hazardous voltage can cause injury or death!

Never leave the board operating unattended. After removing the high voltage from the board, discharge the capacitors with a suitable discharging resistor to avoid electrical shock!



Caution:

This reference design is built with ESD (electrostatic discharge) sensitive components. Always follow ESD prevention procedures when handling the product to avoid failures!

Specifications (measured @ ta= 25°C, 1.5Vin, full load after warm up unless otherwise stated)

BASIC CHARACTERISTICS				
Parameter	Condition	Min.	Typ.	Max.
Input Voltage Con1		15V		42V
Input Voltage Con2 -> Con3	limited by C10	0V		1000V
Digital U1, U2, Enable		-0.5V		5.5V
Logic High Input Threshold		2V		
Logic Low Input Threshold				0.8V
Input Hysteresis		350mV	400mV	
Maximum Ratings		-0.5V		5.5V
Driver Section				
Source and Sink Current (max)				10A
Total Drive Voltage	positive and negative	+4V		30V
Propagation Delay	system before gate resistors	20ns	40ns	70ns
Rise and Fall Times	refer to the datasheet of the gate-driver IC			
Isolation				
Isolation Voltage	input to output	2.5kVDC		

Component Placement

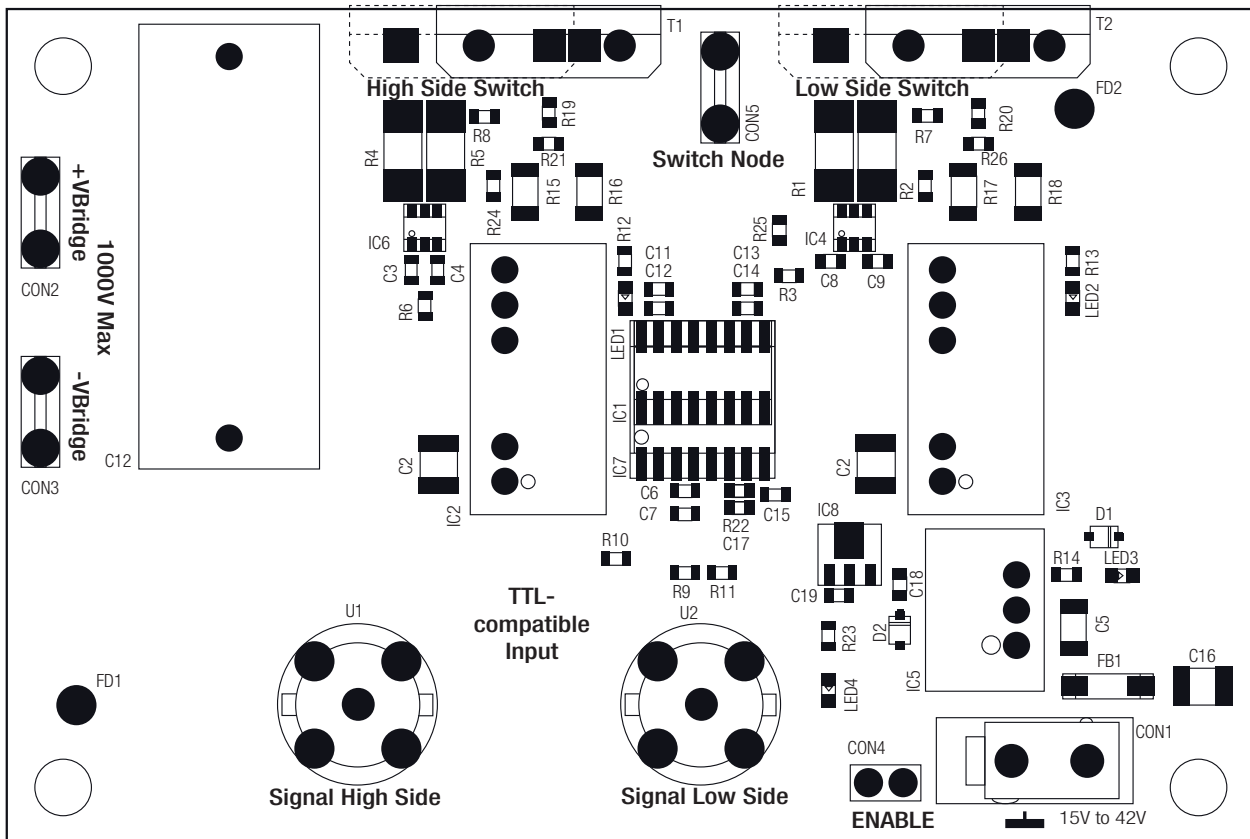

continued on next page

Specifications (measured @ $t_a = 25^\circ\text{C}$, 1.5Vin, full load after warm up unless otherwise stated)

Component List

Part	Description
IC2	DC/DC isolated converter for high-side gate-driver. Depending on the transistor type, fit the appropriate DC/DC converter (please refer to pages P-10 to P-12).
IC3	DC/DC isolated converter for low-side gate-driver. Depending on the transistor type, fit the appropriate DC/DC converter (see table 1).
T1	High-side switching transistor (not supplied). Read important notice below.
T2	Low-side switch transistor (not supplied). Read important notice below.
Note:	The transistors are placed on the edge of the PCB so that they are easy to mount to a heatsink. They can also be mounted inverted on the bottom side of the PCB. Both TO247-3L and TO247-4L format transistors can be used by using the appropriate hole set.
CON1	Connector for logic and driver supply. Connect a 15V, 18V, 24V or 36V DC supply here.
CON2	+V bridge voltage: connect a positive voltage up to 1kV in respect to power-GND to this connector.
CON3	-V bridge voltage: power-GND
CON4	Enable: a high signal enables the driver signals. Place the jumper on the connector to enable the signals permanently
CON5	Switching node of the half-bridge
U1	Signal high-side: TTL-compatible input for the high-side transistor
U2	Signal low-side: TTL-compatible input for the low-side transistor

Following DC/DC models are suitable for use with this reference design

Model	Power [W]	Output Voltage [V]	Application
R12P22005D*	2	+20/-5	SiC MOSFETs
R12P21503D*	2	+15/-3	SiC MOSFETs
R12P21509D*	2	+15/-9	IGBTs
R12P1509D	1	+15/-9	IGBTs
R12P06S*	1	+6	GaN
R12P12S	1	+12	Cascode/Si MOSFET

*these models are included in the reference design. Each of them two times

Truth table (with IC1 SI8273 mounted):

Input			Output		Comment
U1	U2	Enable	High-side Gate	Low-side Gate	
L	L	H	L	L	
L	H	H	L	H	
H	L	H	H	L	
H	H	H	L	L	Invalid state
X	X	L	L	L	Device is disabled

Specifications (measured @ $t_a = 25^\circ\text{C}$, 1.5Vin, full load after warm up unless otherwise stated)

NOTE: TRANSISTORS SOLD SEPARATELY

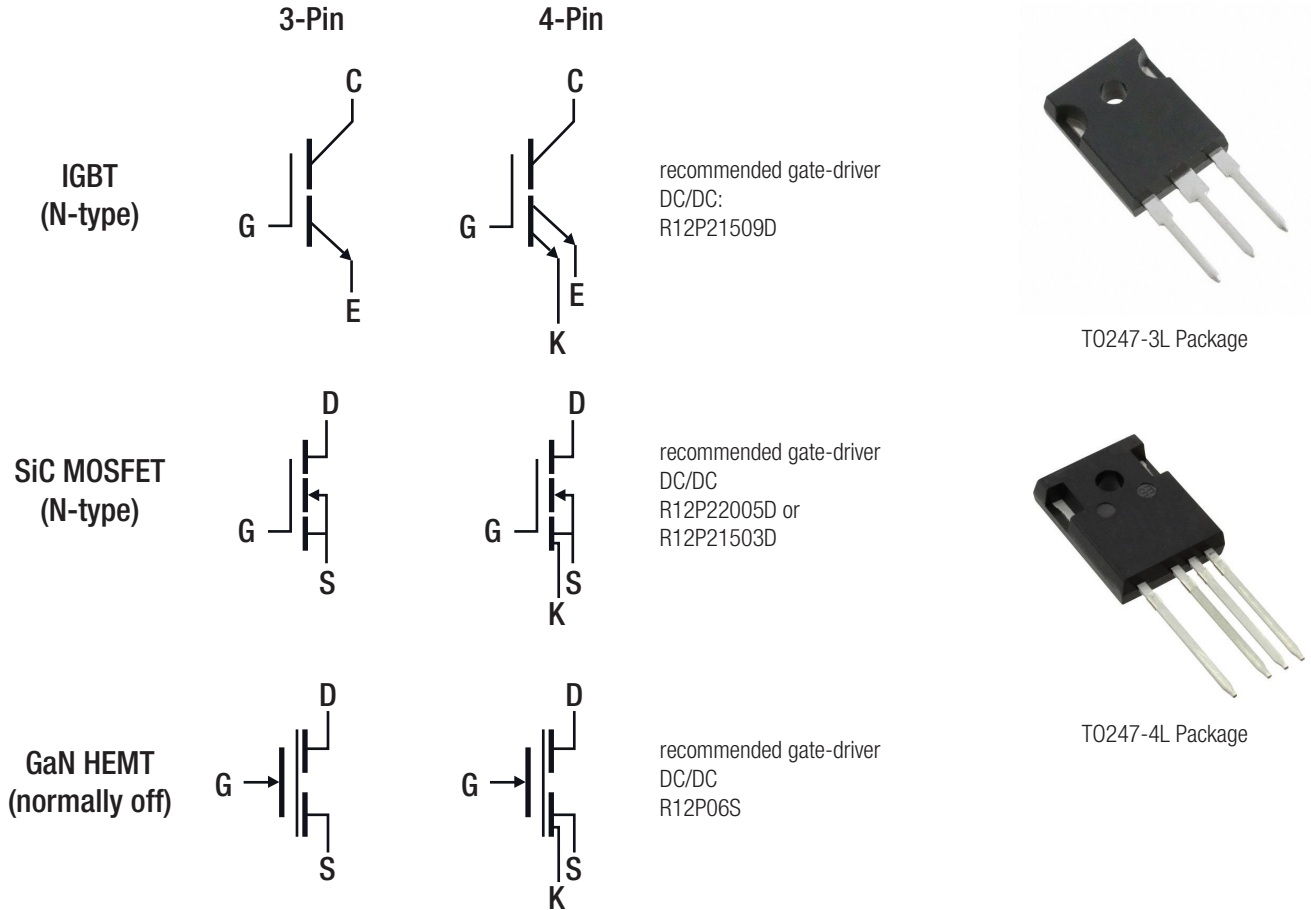

Important: using three pin or four pin T0247 packages:

T0247-4L packages can be used without any modification of the PCB. The Kelvin source pin is already connected to the gate-driver ground.

T0247-3L packages however require a minor modification to join the gate-driver ground to the source pin ground. This can be done by soldering 0Ω resistors across R19 and R20 or by making a solder bridge between the source and Kelvin source pads (recommended for lowest gate inductance).



Specifications (measured @ $t_a = 25^\circ\text{C}$, 1.5Vin, full load after warm up unless otherwise stated)

Schematic

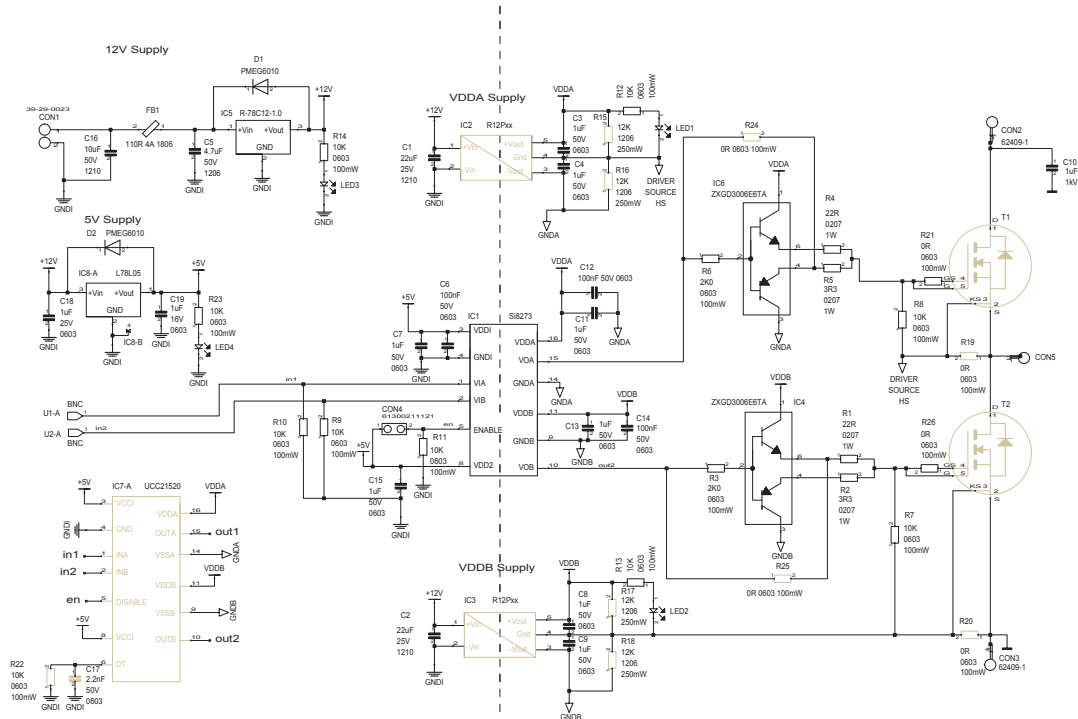

Description:

The reference design board requires a single supply voltage with a range of 15-42V.

IC5 creates the regulated 12V supply for IC2 and IC3.

IC2 generates the isolated high-side gate-driver supply voltage. Choose the appropriate DC/DC converter from the selection provided.

IC3 generates the isolated low-side gate-driver supply voltage. Choose the appropriate DC/DC converter from the selection provided.

IC8 creates a +Vcc rail required for the gate driver.

IC1 isolates the control signals and level shifts the TTL input to the gate-drive voltages.

IC7 can be mounted instead of IC1 if reinforced isolation is required.

IC4 and IC5 amplify the maximum gate-drive current to $\pm 10\text{A}$.

R24 and R25 are not fitted. Zero Ω resistors can be mounted if IC4 and IC5 are not required (for example GaN transistors).

The input GND1 is galvanically isolated from the high-side GNDA and the low-side GNDB.

For single-ended designs, it is recommended to connect GND1 to Power-GND (CON3) with a star-earth configuration.

For full-bridge configurations, couple GND1 to Power-GND with Y-Capacitors to avoid generating high potentials caused by common mode currents.

R15, R16, R17 and R18 are not fitted. The positions can be used to add dummy loads for the power supplies if needed, for example, under very light load conditions or low switching frequencies. Alternately R16 and R18 can be used to allow single-output voltage DC/DC converters to be used by connecting -Vout to the gate-driver ground.

Configuration	R15, R17	R16, R18
Dual Output DC/DC, Normal Load (standard)	Not required	Not required
Dual Output DC/DC, Light Load	12k Ω	12k Ω
Single Output DC/DC, Normal Load	Not required	Zero Ω
Single Output DC/DC, Light Load	12k Ω	Zero Ω

R1 and R4 control the turn-on slew rate. 22 Ω is fitted as standard.

R2 and R5 control the turn-off slew rate. 3.3 Ω is fitted as standard.

These O207 package resistors are made to withstand highly pulsed loads. Gate currents up to 10A are possible.

Specifications (measured @ ta= 25°C, 1.5Vin, full load after warm up unless otherwise stated)

Layout

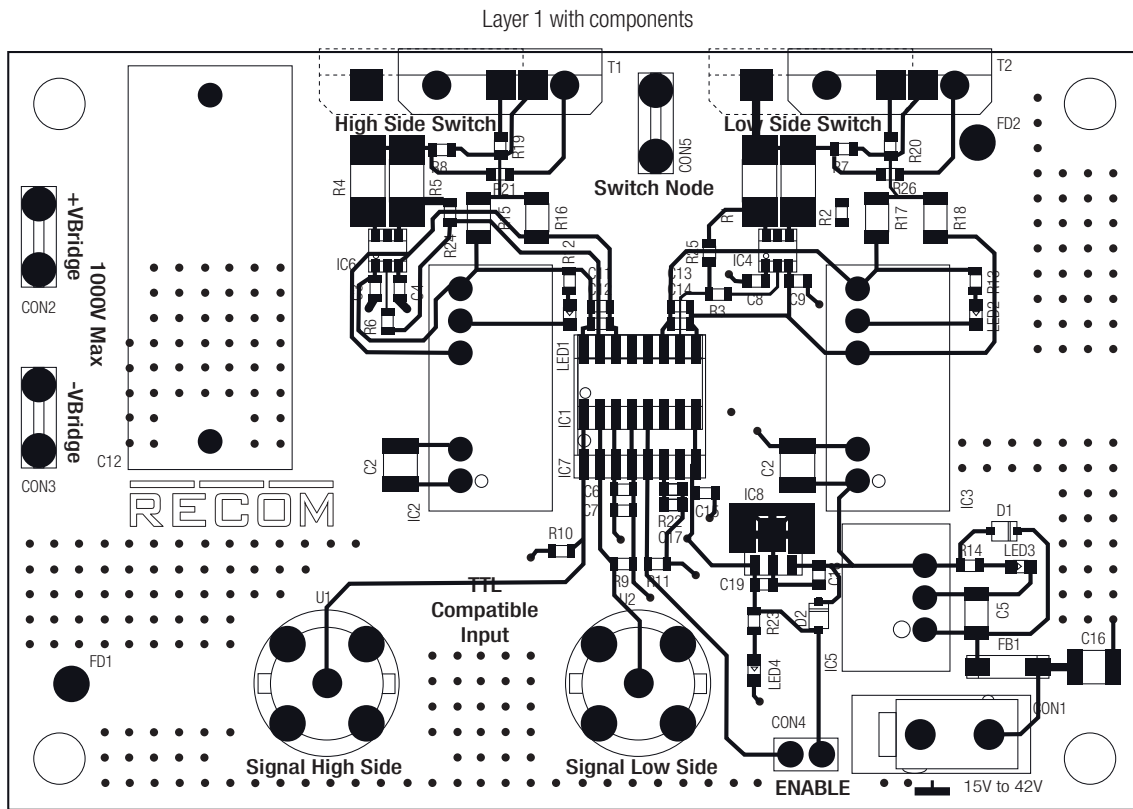

Layer 2

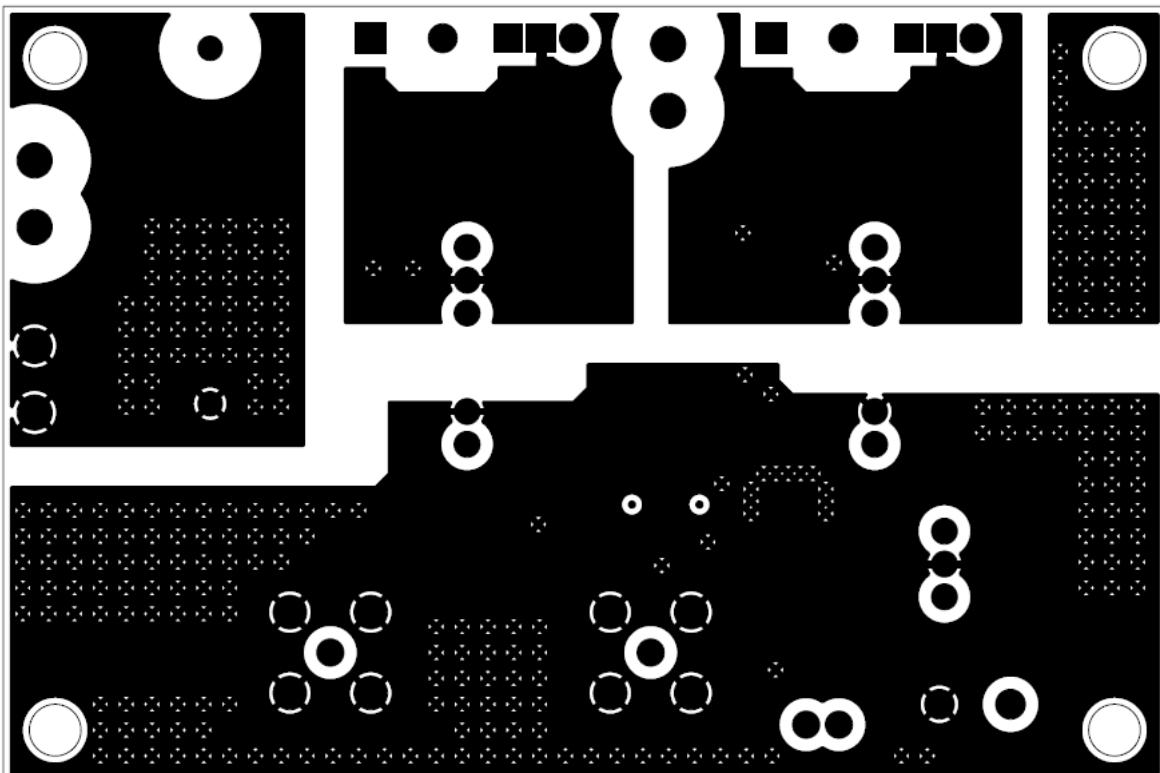

Specifications (measured @ $t_a = 25^\circ\text{C}$, 1.5Vin, full load after warm up unless otherwise stated)

Layer 3

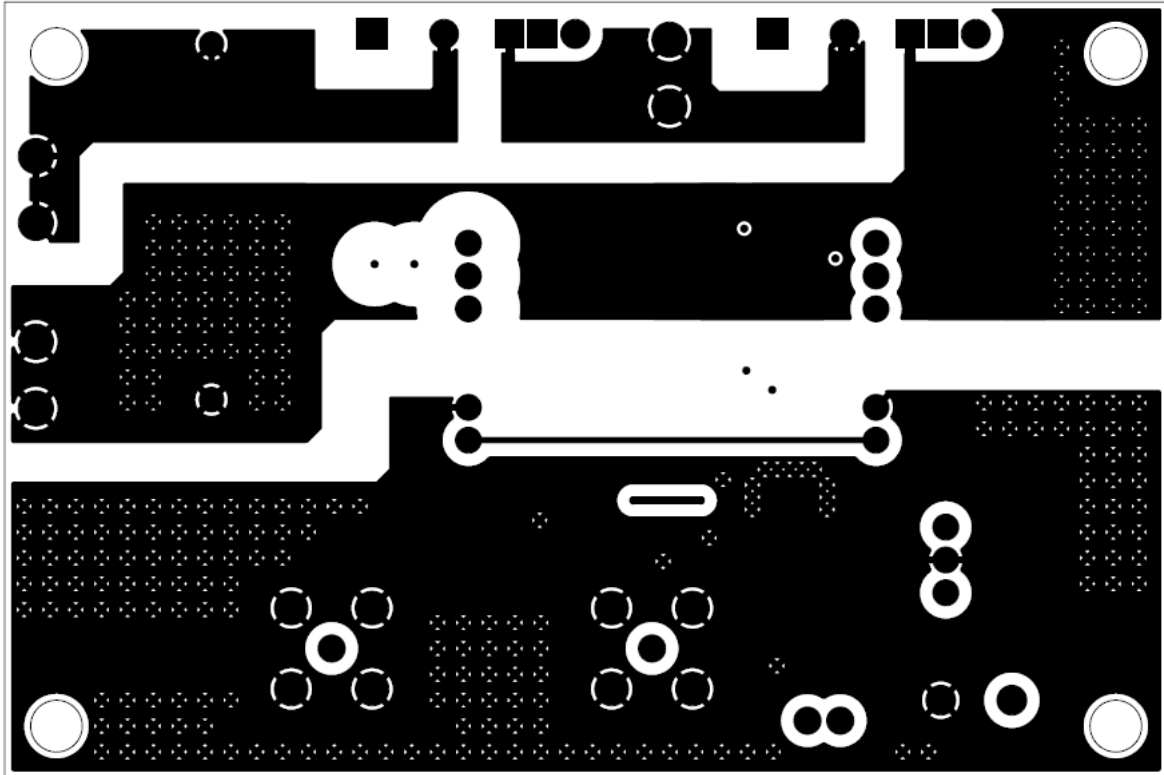

Bottom View

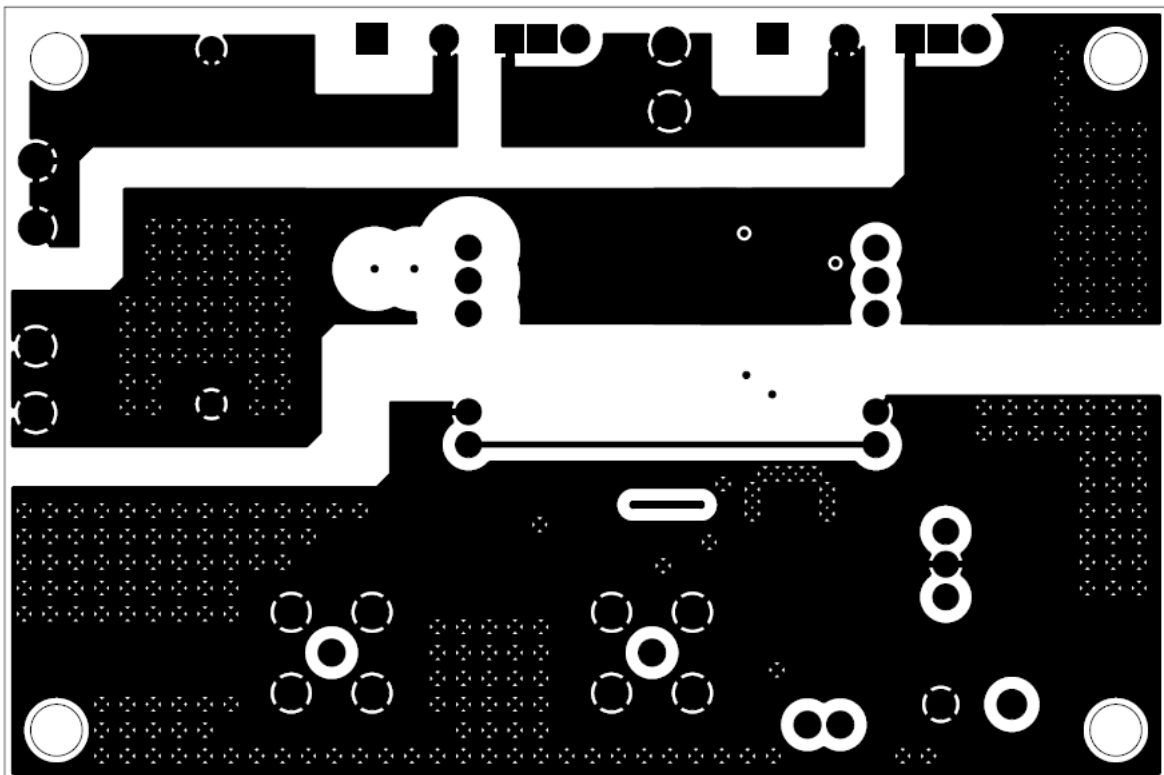

Specifications (measured @ ta= 25°C, 1.5Vin, full load after warm up unless otherwise stated)

BOM					
Part Name/Number	Description	Manufacturer Part Number	Manufacturer	Qty.	Comps.
74279245	FERRITE BEAD 110Ω 1806 1LN	74279245	Würth	1	FB1
BNC_500HM_6.26mm_THD	CONN BNC JACK STR 50Ω PCB	5-1634503-1	TE Connectivity	2	U1 U2
C1μF-1kV-FOIL-32mmX13mm	CAP FILM 1μF 10% 1kVDC RADIAL	R71QR41004010K	KEMET	1	C10
C1μF-0603-16V	CAP CER 1μF 16V X7R 0603	CC0603KRX7R7BB105	Yageo	1	C19
C1μF-0603-25V	CAP CER 1μF 25V X7R 0603	TMK107B7105KA-T	Taiyo Yuden	1	C18
C1μF-0603-50V	1μF ±10% 50V X7R MLCC CAPACITOR 0603	UMK107AB7105KA-T	Taiyo Yuden	8	C3 C4 C7 C8 C9 C11 C13 C15
C2.2nF-0603-50V	CAP CER 2200pF 50V X7R 0603	CC0603KRX7R9BB222	Yageo	1	C17
C3M0120100K-HYBRID	1000V 120mΩ G3 SIC MOSFET	C3M0120100K	Cree/ Wolfspeed	2	T1 T2
C4.7μF-1206-50V	4.7μF ±10% 50V X7R MLCC CAPACITOR 1206	UMK316AB7475KL-T	Taiyo Yuden	1	C5
C10μF-1210-50V	CAP CER 10μF 50V X7R 1210	UMK325AB7106KMHT	Taiyo Yuden	1	C16
C22μF-1210-25V	CAP CER 22μF 25V X7R 1210	TMK325B7226KM-PR	Taiyo Yuden	2	C1 C2
C100nF-0603-50V	0.10μF ±20% 50V X7R CERAMIC CAPACITOR SURFACE MOUNT MLCC 0603	C0603C104M5RACTU	Kemet	3	C6 C12 C14
CONNECTOR_2X1_5.5mm	MOLEX MINI-FIT JR	39-29-0023	Molex	1	CON1
CONNECTOR_6.35mmX0.83mm	FASTON 250 PCB TAB TPBR 6.35 x 0.83mm L=15.8mm	62409-1	TE Connectivity	3	CON2 CON3 CON5
HEADER_2X2.54mm_WURTH	CONN HEADER 2 POS 2.54	61300211121	Würth	1	CON4
L78L05ABUTR	IC REG LINEAR 5V 100mA SOT89-3	L78L05ABUTR	STMicroelect- ronics	1	IC8
LED-0603-GREEN-3.2V	LED GREEN CLEAR 0603 SMD	150060GS75000	Würth	4	LED1 LED2 LED3 LED4
PMEG6010-SOD323	DIODE SCHOTTKY 60V 1A SOD323F PMEG6010	PMEG6010CEJ	NXP	2	D1 D2
R0-0603	RES SMD 0.0Ω JUMPER 1/10W 0603	RC0603JR-070RL	Yageo	4 2	R19 R20 R24 R25 R21 R26
R2K0-0603	RES SMD 2kΩ 1% 1/10W 0603	RC0603FR-072KL	Yageo	2	R3 R6
R3E3-0207-MELF	RES SMD 3.3Ω 1% 1W 0207	MMB02070C3308FB200	Vishay Bey- schlag	2	R2 R5
R12P22005D	CONV DC/DC 2W 5VIN +20/-5VOUT	R12P22005D	RECOM	2	IC2 IC3
R10K0-0603	RES SMD 10kΩ 1% 1/10W 0603	RC0603FR-0710KL	Yageo	1 9	R22 R7 R8 R9 R10 R11 R12 R13 R14 R23
R22E0-0207-MELF	RES SMD 22Ω 1% 1W 0207	MMB02070C2209FB200	Vishay Bey- schlag	2	R1 R4
R47K-1206	RES SMD 47kΩ 1% 1/4W 1206	RC1206FR-0747KL	Yageo	4	R15 R16 R17 R18
R-78C12-1.0	CONV DC/DC 1A 12V OUT SIP VERT	R-78C12-1.0	RECOM	1	IC5
SI8273GBD-IS1	OPTOISO 2.5kV GATE DRVR 16SOIC	SI8273GBD-IS1	Silicon Labs	1	IC1
UCC21520	OPTOISO 5.7kV GATE DRVR 16SOIC	UCC21520ADW	Texas Instru- ments	1	IC7
ZXGD3006E6TA	IC GATE DRVR IGBT/MOSFET SOT26	ZXGD3006E6TA	Diodes Incor- porated	2	IC4 IC6

Specifications (measured @ $t_a = 25^\circ\text{C}$, 1.5Vin, full load after warm up unless otherwise stated)

Typical Switching Waveforms

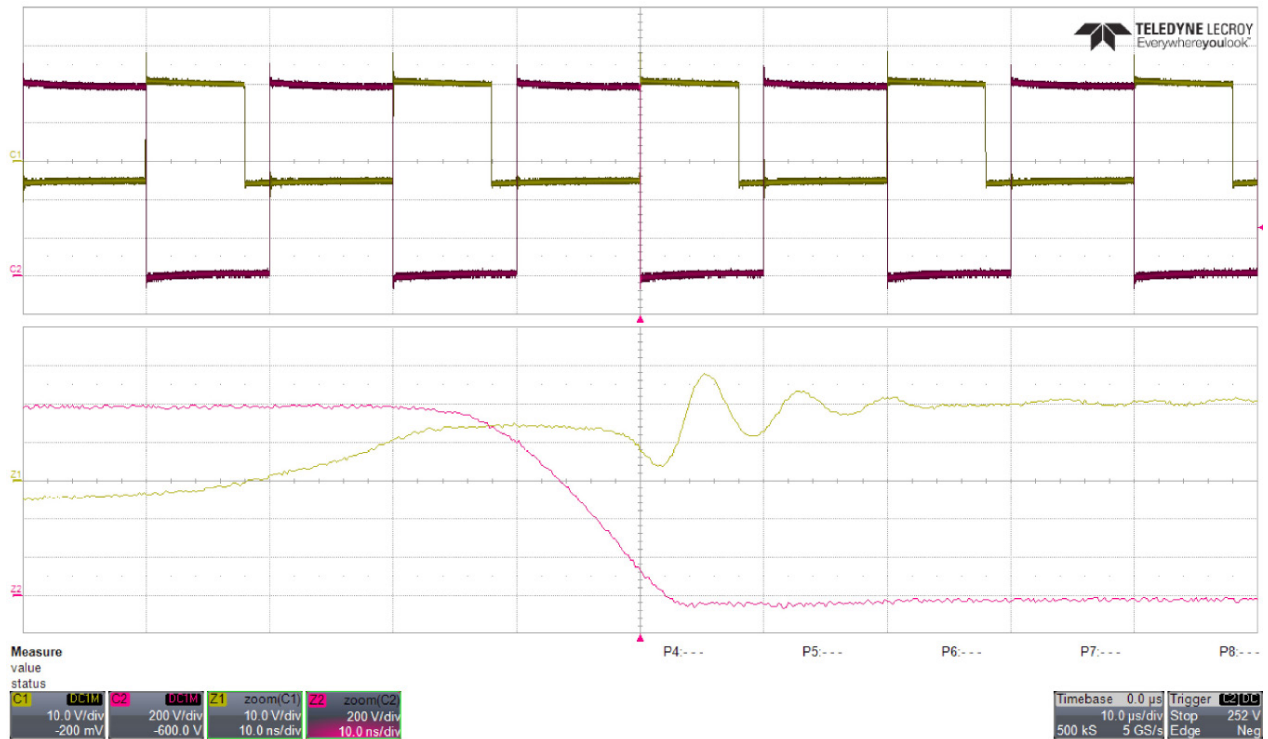

Ch.1: Low-side Gate Source Voltage
Ch.2: Low-side Drain Source Voltage

Switching Voltage: 1000VDC
Transistor: C2M1000170D-ND
IC2/IC3: R12P22005D

Switching Frequency: 50kHz
Measured Switching Slew Rate: 65kV/ μs
Measured Switching Time: 15ns

Specifications (measured @ $t_a = 25^\circ\text{C}$, 1.5Vin, full load after warm up unless otherwise stated)

Application Suggestion

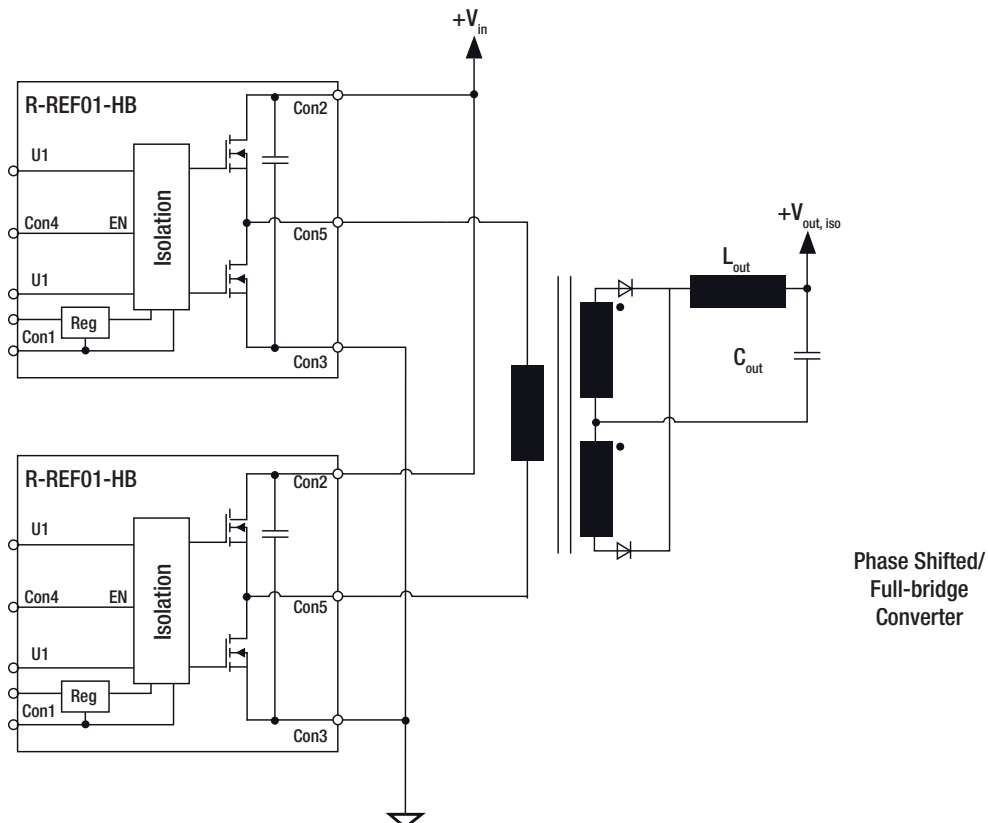
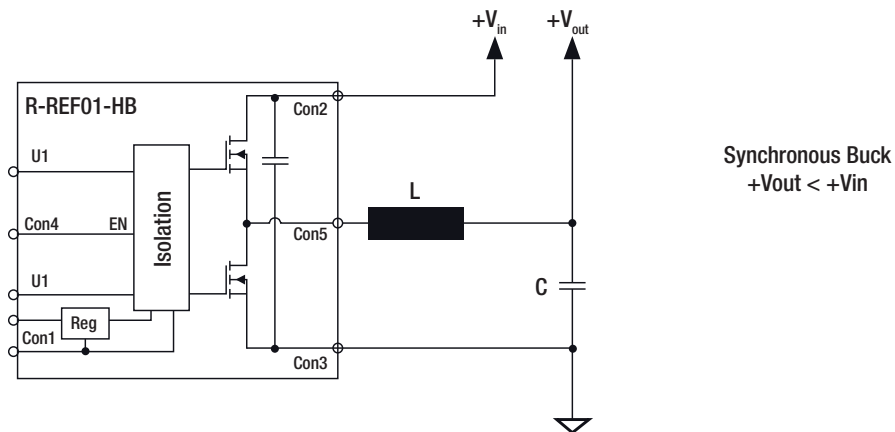
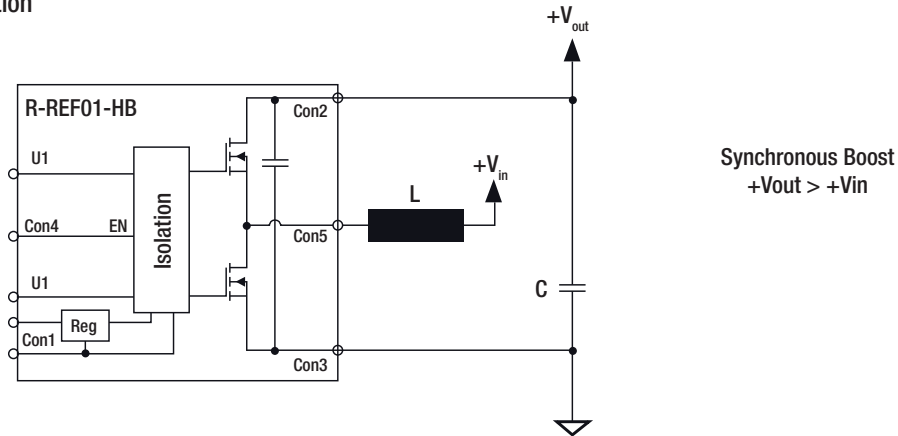

Specifications (measured @ $t_a = 25^\circ\text{C}$, 1.5V_{in}, full load after warm up unless otherwise stated)

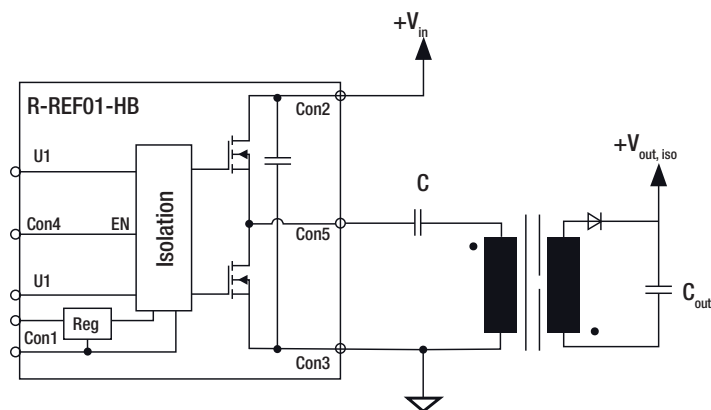

Half-bridge
Flyback
Converter

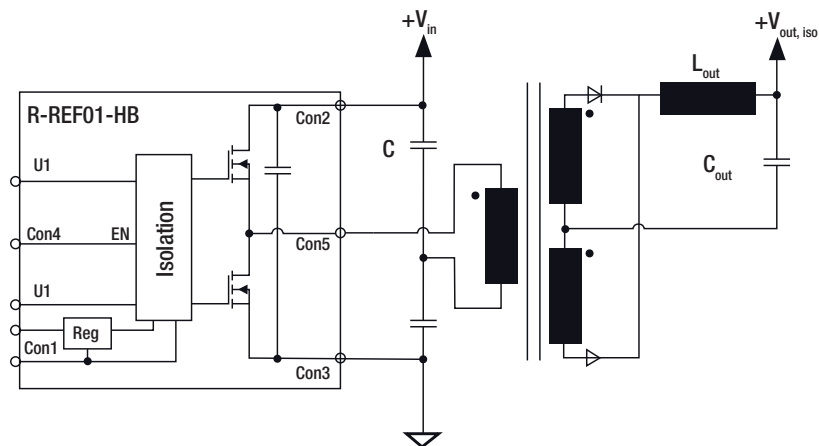

Half-bridge
Forward
Converter

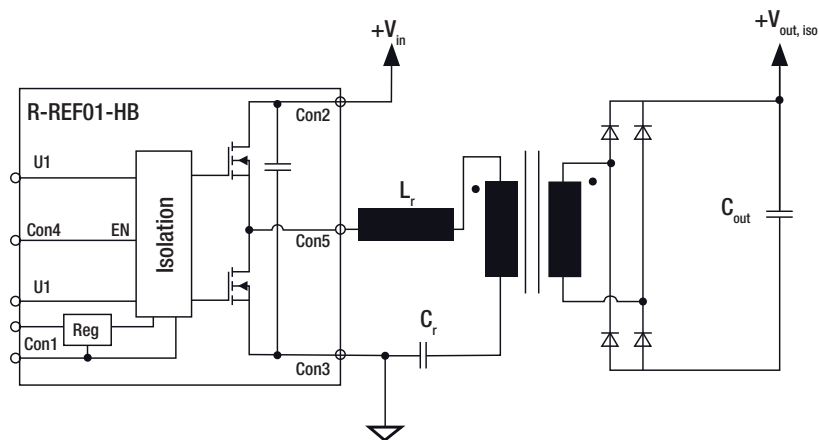

Half-bridge
LLC
Converter

Specifications (measured @ $t_a = 25^\circ\text{C}$, $1.5V_{in}$, full load after warm up unless otherwise stated)

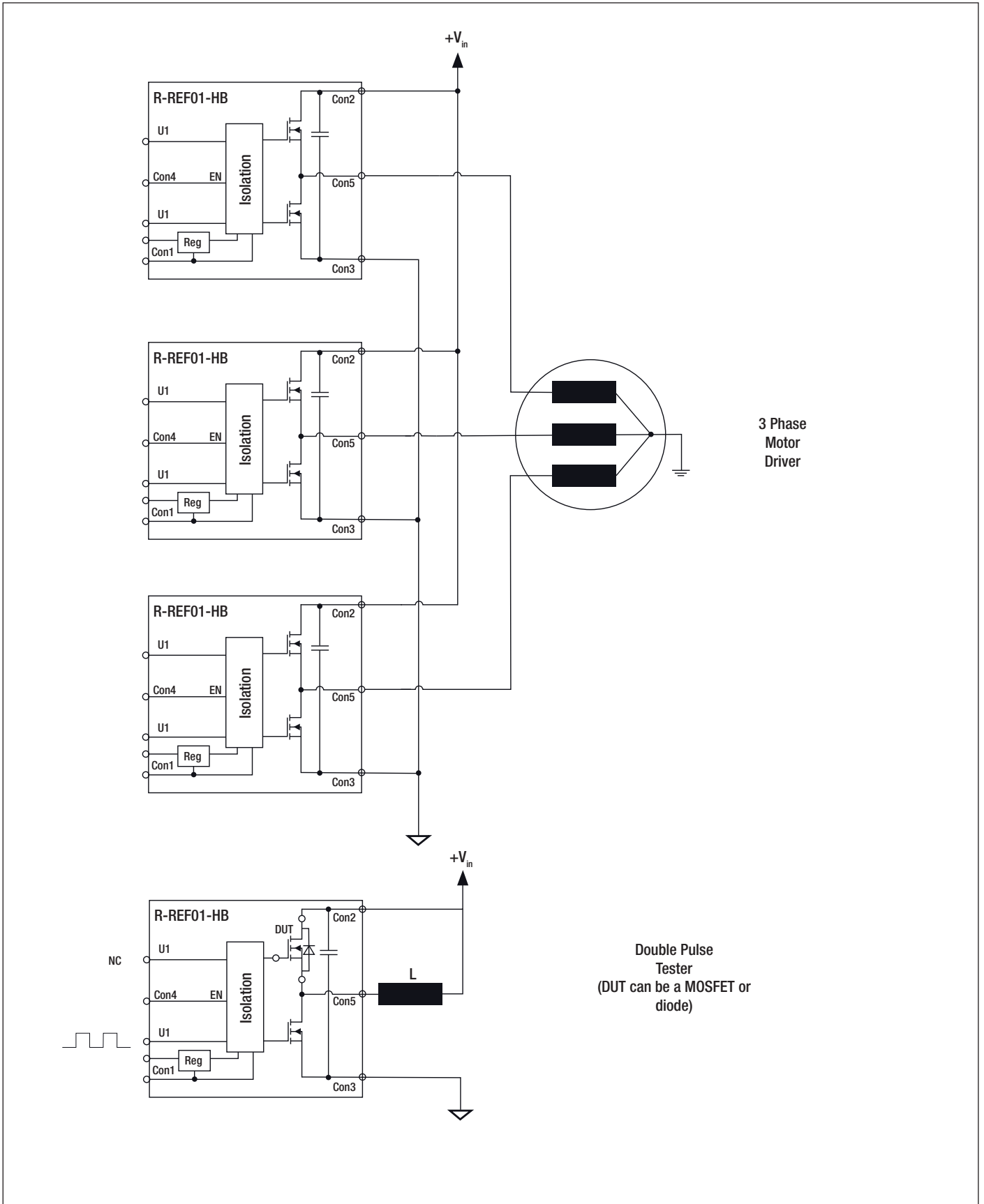

The product information and specifications may be subject to changes even without prior written notice. The product has been designed for various applications; its suitability lies in the responsibility of each customer. The products are not authorized for use in safety-critical applications without RECOM's explicit written consent. A safety-critical application is an application where a failure may reasonably be expected to endanger or cause loss of life, inflict bodily harm or damage property. The applicant shall indemnify and hold harmless RECOM, its affiliated companies and its representatives against any damage claims in connection with the unauthorized use of RECOM products in such safety-critical applications.