

4

3

2

1

THIS DRAWING IS UNPUBLISHED. RELEASED FOR PUBLICATION
 © COPYRIGHT - By - ALL RIGHTS RESERVED.

LOC		DIST		REVISIONS			
P	LTR	DESCRIPTION	DATE	DWN	APVD		
HB	-						
	D	CHANGE LOGO, ADD CQC, LINE IDENTIFIER AND PLATING THICKNESS	ECO-12-005725	21-AUG-12	D.L	BH.Y	
	E	REVISE ONLY	ECO-13-015347	16-DEC-13	XL,Y	B,F	

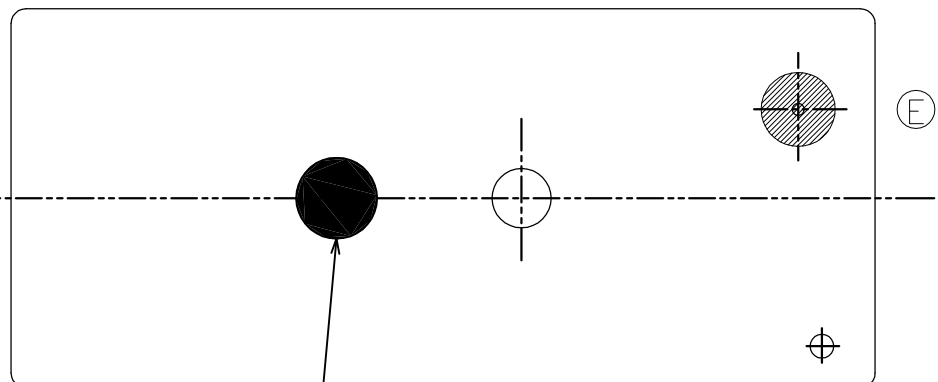

DOT MARK:BLACK (C)(D)
 PART A PART B C:MADE IN CHINA

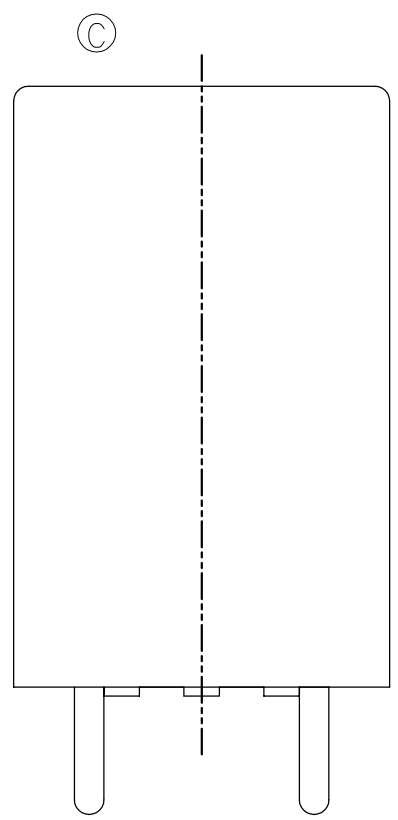
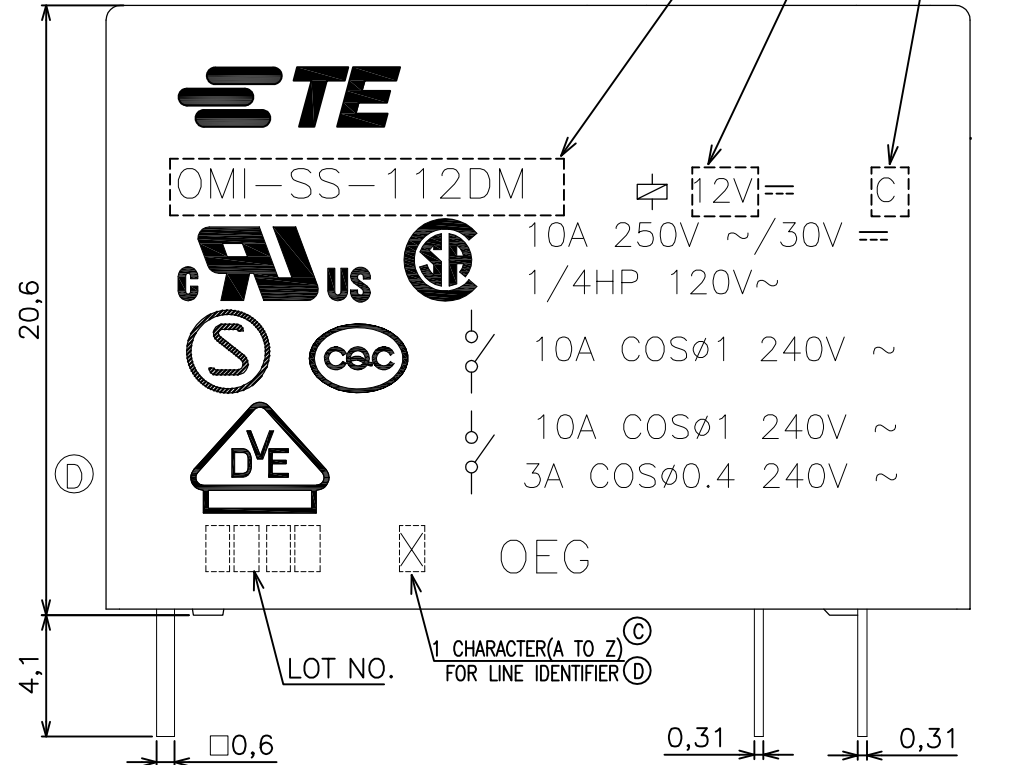

NOTES:
 1.-SS- : PLASTIC SEALD TYPE
 2.LOT NO. SYSTEM AS FOLLOWING:

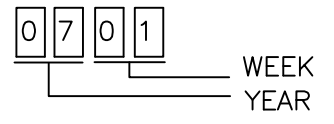

3.GENERAL TOLERANCE AS FOLLOWING:

TOLERANCE	
0~0.99mm	±0.1
1mm~2.99mm	±0.2
3mmMIN.	±0.3

(D) 4.TERMINAL DIMENSION IS NOT INCLUDING SOLDER TIP.
 FOR THE TIN-PLATING OF THE PINS:
 +0.1mm FOR WIDTH,THICKNESS AND DIAMETER.
 +0.5mm FOR LENGTH.

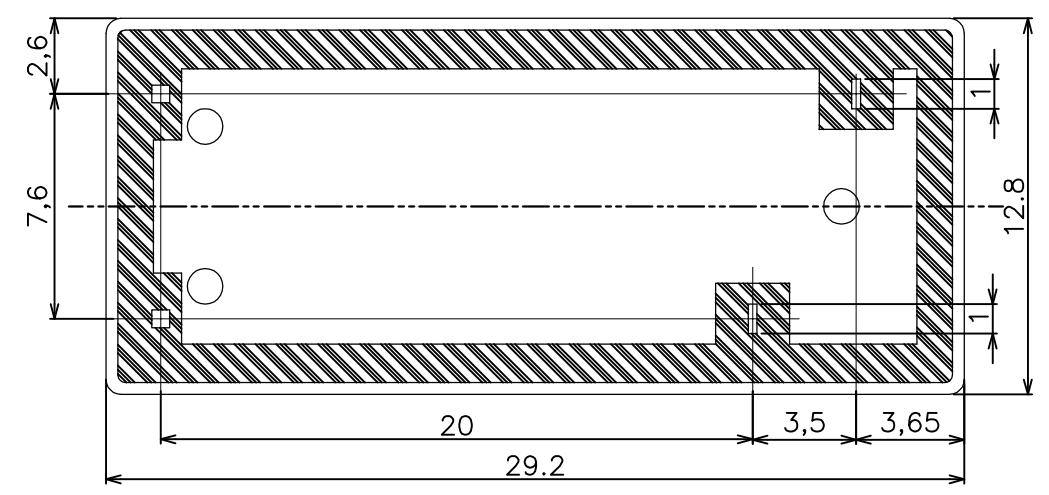

THIS DRAWING IS A CONTROLLED DOCUMENT.		DWN H.SASAKI	STE TE Connectivity	
DIMENSIONS: mm		CHK Y.OIKAWA		
TOLERANCES UNLESS OTHERWISE SPECIFIED:		APVD A.NAGAI	NAME	
0 PLC ± -		PRODUCT SPEC	OMI-SH-LM SPEC,095 CUSTOMER DRAWING	
1 PLC ± -		APPLICATION SPEC	SIZE	CAGE CODE
2 PLC ± -		WEIGHT	A3	00779
3 PLC ± -		CUSTOMER DRAWING	DRAWING NO	
4 PLC ± -		SCALE	C-9-1419121-4	
ANGLES ± -		4:1	RESTRICTED TO	
FINISH		SHEET	1 OF 2	
		REV	E	

4

3

2

1

THIS DRAWING IS UNPUBLISHED.

RELEASED FOR PUBLICATION

ALL RIGHTS RESERVED.

© COPYRIGHT - By -

LOC	DIST	REVISIONS					
		P	LTR	DESCRIPTION	DATE	DWN	APVD
HB	-						

CONNECTION DIAGRAM (BOTTOM VIEW)

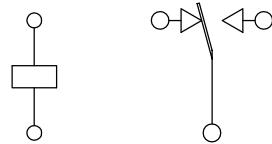

DRILLING DIAGRAM(2/1) (BOTTOM VIEW)

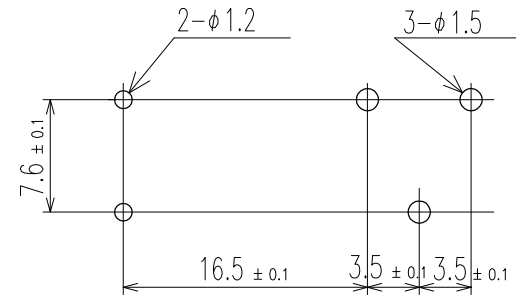

TE PART NO	TE TYPE NAME	PART B	PART A
9-1419121-5	OMI-SH-109LM	9V	OMI-SH-109LM
9-1419121-4	OMI-SH-105LM	5V	OMI-SH-105LM

RELAY TYPE

		EPOXY RESIN	RESIN	17
UL94 V-0		PBT	CASE	16
		-	TAPE	15
CLASS E		UEW	MAGNETIC WIRE	14
UL94 V-0		PET	BASE	13
UL94 V-0		PBT	BOBBIN	12
	SOLDER DIP	CP WIRE	COIL TERMINAL	11
UL94 V-0		PPS	CARD	10
		Ag ALLOY	MOVABLE CONTACT	9
		Ag ALLOY	STATIONARY CONTACT	8
		Cu ALLOY	HINGE SPRING	7
	SOLDER DIP	Cu ALLOY	B TERMINAL	6
	SOLDER DIP	Cu ALLOY	M TERMINAL	5
	SOLDER DIP	Cu ALLOY	MOVABLE SPRING	4
		STEEL	CORE	3
		STEEL	ARMATURE	2
		STEEL	YOKE	1
INCOMBUSTIBILITY	TREATMENT	MATERIAL	DESCRIPTION	ITEM

THIS DRAWING IS A CONTROLLED DOCUMENT.		DWN H.SASAKI	STE TE Connectivity		
DIMENSIONS: mm		CHK Y.OIKAWA			
TOLERANCES UNLESS OTHERWISE SPECIFIED:		APVD A.NAGAI	NAME		
0 PLC ± -		PRODUCT SPEC	OMI-SH-LM SPEC,095 CUSTOMER DRAWING		
1 PLC ± -		APPLICATION SPEC	SIZE	CAGE CODE	DRAWING NO
2 PLC ± -		WEIGHT	A3	00779	C-9-1419121-4
3 PLC ± -		CUSTOMER DRAWING	RESTRICTED TO		-
4 PLC ± -			SCALE	SHEET	REV
ANGLES ± -			4:1	2 of 2	E
FINISH					