

SILICON BRIDGE RECTIFIERS

VOLTAGE RANGE: 50 --- 1000 V
CURRENT: 1.0 A

FEATURES

- ◇ Rating to 1000VPRV
- ◇ Surge overload rating to 50 Amperes peak
- ◇ Ideal for printed circuit board
- ◇ Reliable low cost construction utilizing molded plastic technique results in inexpensive product
- ◇ Lead solderable per MIL-STD-202 method 208
- ◇ Plastic material has UL flammability classification 94V-O
- ◇ Glass passivated junction
- ◇ Weight: 0.05 ounces, 1.52 grams

GBP

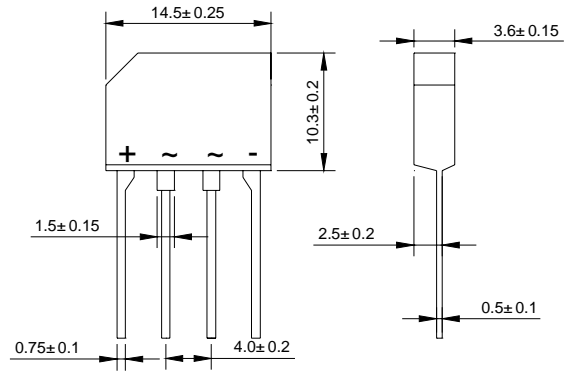

Dimensions in millimeters

MAXIMUM RATINGS AND ELECTRICAL CHARACTERISTICS

Ratings at 25°C ambient temperature unless otherwise specified.

Single phase, half wave, 60 Hz, resistive or inductive load. For capacitive load, derate by 20%.

		GBP 1005	GBP 101	GBP 102	GBP 104	GBP 106	GBP 108	GBP 110	UNITS
Maximum recurrent peak reverse voltage	V_{RRM}	50	100	200	400	600	800	1000	V
Maximum RMS voltage	V_{RMS}	35	70	140	280	420	560	700	V
Maximum DC blocking voltage	V_{DC}	50	100	200	400	600	800	1000	V
Maximum average forward Output current @ $T_A=25^\circ C$	$I_{F(AV)}$	1.0							A
Peak forward surge current 8.3ms single half-sine-wave superimposed on rated load	I_{FSM}	50							A
Maximum instantaneous forward voltage @ 0.5 A	V_F	1.05							V
Maximum reverse current @ $T_A=25^\circ C$ at rated DC blocking voltage @ $T_A=125^\circ C$	I_R	10.0 1.0							μA mA
Operating junction temperature range	T_J	- 55 ---- + 150							°C
Storage temperature range	T_{STG}	- 55 ---- + 150							°C

FIG.1 – PEAK FORWARD SURGE CURRENT

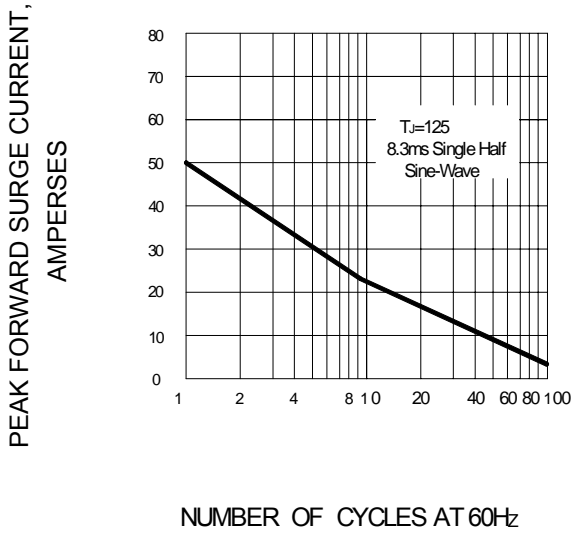

**FIG.2 – FORWARD DERATING CURVE
OUTPUT RECTIFIED CURRENT**

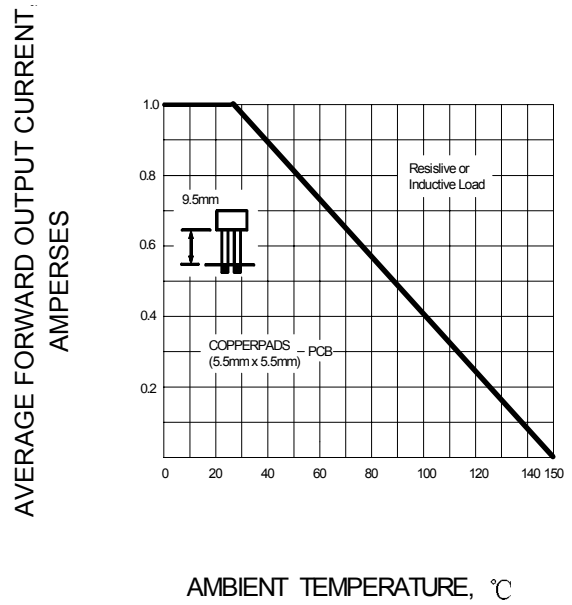

FIG.3 – TYPICAL FORWARD CHARACTERISTICS

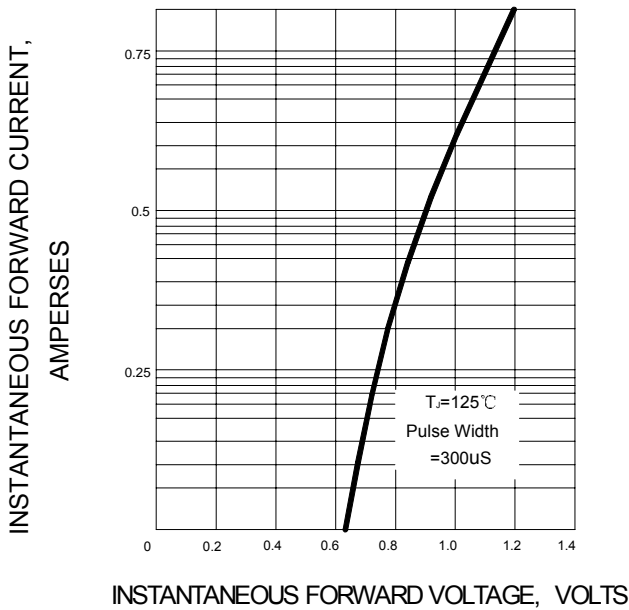

FIG.4 – TYPICAL REVERSE CHARACTERISTICS

