



# LED-12W Series

Switch Mode LED Drivers  
Constant Current & Constant Voltage with Isolation  
Black Magic Thermal Advantage™ Plastic Housing

## Electrical Specifications

Input Voltage Range:	100-277 Vac Nom. (90-305 V Min/Max)
Input Over-Voltage:	Can endure 320Vac for 48 Hrs, 350Vac for 2 Hrs
Frequency:	50/60 Hz Nom. (47-63 Hz Min/Max)
Power Factor:	>0.90 @ 120V, >0.75 @ 277V
Inrush Current:	<15.0 Amps max @ 230 Vac, cold start 25°C
Input Current:	0.15 Amps max at 120 Vac
Maximum Power:	12W
Line Regulation:	± 1% (when applicable)
Load Regulation:	± 3%
THD:	≤ 20% @ 120 Vac, ≤ 35% @ 277 Vac
Leakage Current:	300 µA Typical
Hold Up Time:	Half Cycle
Protection:	Output Over-Voltage, Output Over-Current, and Output Short Circuit Protection with Auto Recovery

## Environmental Specifications

Minimum Starting Temp:	-30°C
Storage Temperature:	-40°C to +85°C
Maximum Case Temp.	90°Cv
Humidity:	5% to 95%
Cooling:	Convection
Vibration Frequency:	5 to 55 Hz/2g, 30 minutes
Sound Rating:	Class A
MTBF:	>550,000 Hours @ full load & 40°C ambient conditions per MIL-217F Notice 2
EMC:	Compliant to CISPR 22 Class B, CISPR 14-1 Class B, GB4343 1-2003, GB17625.1-2003
Weight:	4.5 oz. (128 g)



- Total Power: 12 Watts
- Input Voltage: 100-277 Vac Nom.
- UL Dry & Damp Location Rated
- Suitable for use signs (UL48)
- High Power Factor
- UL Sign Components Manual (S.A.M. Models)

Constant Current - Product Specifications				
Model Number	Output Current (mA ±5%)	Output Voltage Range (Vdc)	Max. Output Power (W)	Typical Efficiency
LED12W-48-C0250	250	24-48	12	82%
LED12W-36-C0350	350	18-36	12.6	81%
LED12W-24-C0350	350	16.4-24	8.2	80%
LED12W-24-C0500	500	12-24	12	80%
LED12W-16-C0700	700	11.2-16	11.2	79%
LED12W-16-C0800	800	8-16	12.8	79%
LED12W-12-C1000	1000	6-12	12	78%

Constant Voltage - Product Specifications				
Model Number	Output Voltage (Vdc ±5%)	Output Current Range (mA)	Max. Output Power (W)	Typical Efficiency
LED12W-12 •	12	250-1000	12	78%
LED12W-16	16	200-800	12.8	79%
LED12W-24 •	24	125-500	12	80%
LED12W-36	36	88-350	12.6	81%
LED12W-48	48	62-250	12	82%

• Indicates S.A.M.



Class 2: US/Canada US Only

Safety and EMC Compliance	
UL/CUL	UL8750
CSA	22.2
C E	EN61347
FCC, 47CFR Part 15	Class B

**Note:**  
LED drivers are designed and intended to operate LED loads only. Non-LED loading may be outside the specified design limits of our LED drivers, and therefore cannot be covered by any warranty. If you desire to use our LED drivers to operate non-LED loads please contact us to discuss compatibility.

Specifications subject to change without notice.

Rev 9-8-15

**Dimensions - IN[mm]**

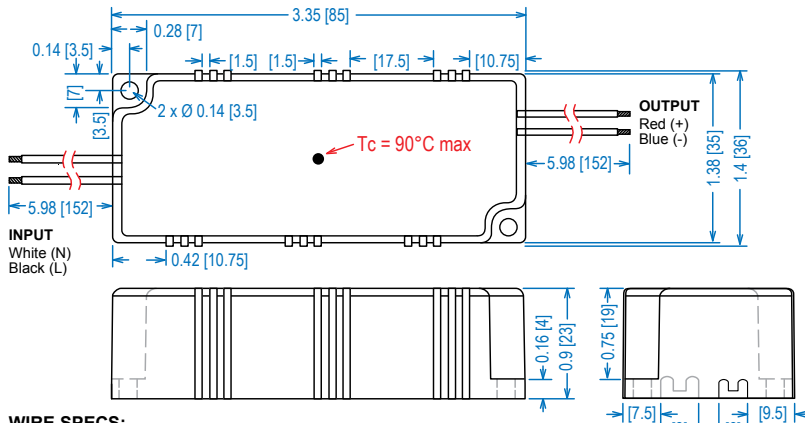

**WIRE SPECS:**

**Input Leads:** 18 AWG, rated 600 V, 105C, min.  
**Output Leads:** 18 AWG, rated 300 V, 105C, min.  
 All wires are stranded with solder dipped ends.

**Power Factor / Load**

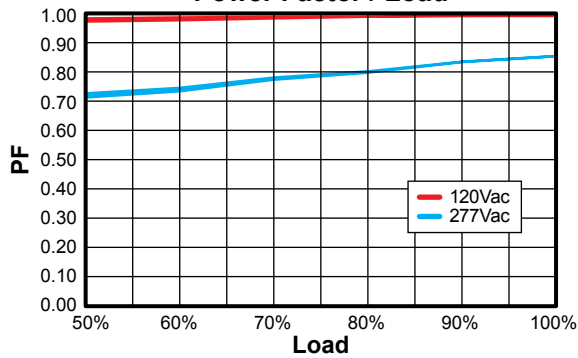

**THD / Load**

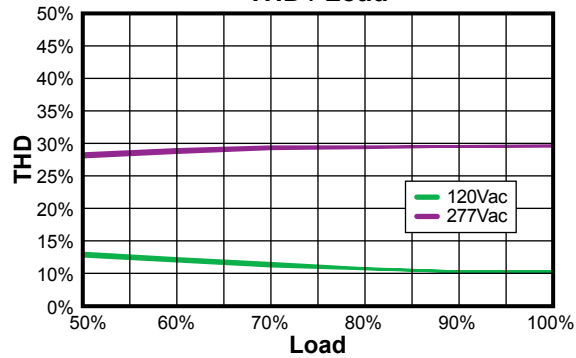

**Lifetime / Case Temperature**

(Full Load @ 120Vac)

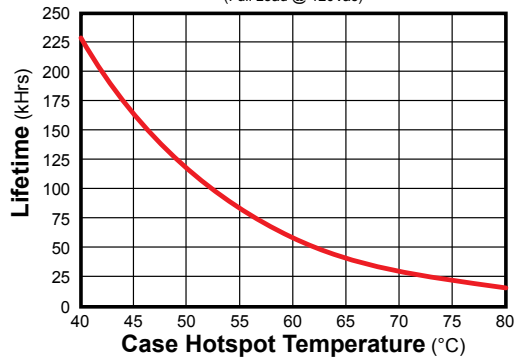

**Note:**

Life calculations are based on reliability with confidence using a 90% confidence level and <5% failure rate. At a confidence level of 90% it is expected that <5% of the parts will fail at the rated life provided. (Failure is defined as a driver drifting outside specification, rather than fail to operate)