

1. Mechanical Dimensions:

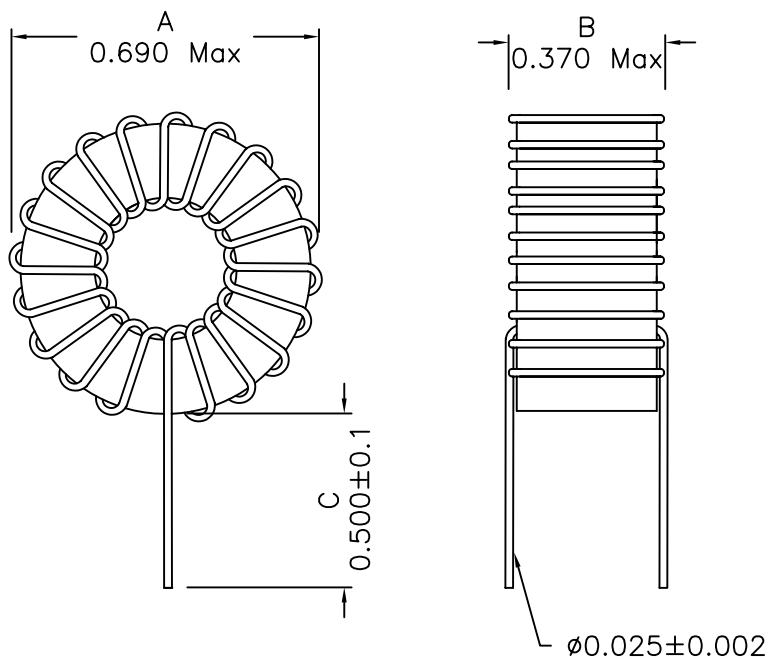

2. Schematic:

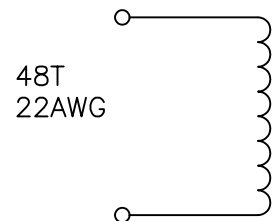

Micrometals T60-26 or equiv

3. Electrical Specifications: @25°C

OCL: 100uH+30%/-5% @10KHz 0.1V

OCL: 97uH Min @10KHz 0.1V, 1Adc

DC Resistance: 0.060 Ohms +10%/-25%

Etop: 103V-uSec @50KHz

Etop: 59V-uSec @100KHz

Note:

1. Solderability: Leads shall meet MIL-STD-202, Method 208D for solderability.
2. Flammability: UL94V-0,
3. ASTM oxygen index: > 28% ,
4. Temperature rating: 155°C. UL file E151556,
5. Operating Temperature Range: -40°C to +85°C

DOC. REV: A/3

XFMRs Inc	Title: TOROIDAL INDUCTOR		
	UNLESS OTHERWISE SPECIFIED TOLERANCES: .xxx ±0.010 Dimensions in INCH	P/N: XF1006-VO2	REV. A
SHEET 1 OF 1	DWN.	廖玉坤	Mar-30-04
	CHK.	李清儿	Mar-30-04
	APP.	MS	Mar-30-04

PROPRIETARY

Document is the property of XFMRs Group & is not allowed to be duplicated without authorization.