

Silicon NPN Power Transistors

2SC3949

DESCRIPTION

- With TO-3PML package
- High voltage ,high speed

APPLICATIONS

- For TV horizontal output and power switching applications

PINNING

PIN	DESCRIPTION
1	Base
2	Collector
3	Emitter

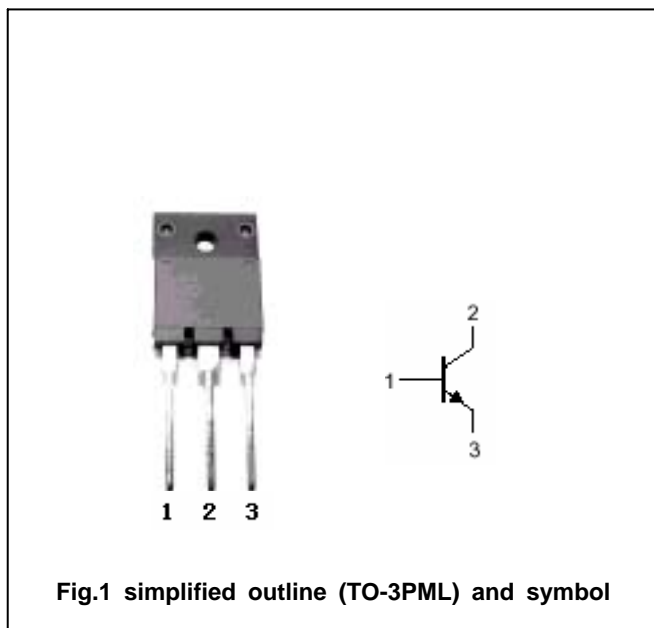

Fig.1 simplified outline (TO-3PML) and symbol

Absolute maximum ratings (Ta=25)

SYMBOL	PARAMETER	CONDITIONS	MAX	UNIT
V_{CBO}	Collector-base voltage	Open emitter	850	V
V_{CEO}	Collector-emitter voltage	Open base	500	V
V_{EBO}	Emitter-base voltage	Open collector	7	V
I_C	Collector current		15	A
P_C	Collector dissipation	$T_C=25$	80	W
T_j	Junction temperature		150	
T_{stg}	Storage temperature		-55~150	

Silicon NPN Power Transistors

2SC3949

CHARACTERISTICS

T_j=25 unless otherwise specified

SYMBOL	PARAMETER	CONDITIONS	MIN	TYP.	MAX	UNIT
V _{(BR)CEO}	Collector-emitter breakdown voltage	I _C =10mA ; R _{BE} =	500			V
V _{(BR)CBO}	Collector-base breakdown voltage	I _C =1mA ; I _E =0	850			V
V _{(BR)EBO}	Emitter-base breakdown voltage	I _E =1mA ; I _C =0	7			V
V _{CEsat}	Collector-emitter saturation voltage	I _C =10A ; I _B =2A			1.0	V
V _{BEsat}	Base-emitter saturation voltage	I _C =10A ; I _B =2A			1.5	V
I _{CBO}	Collector cut-off current	V _{CE} =800V ; I _E =0 T _C =100			0.1 1.0	mA
I _{EBO}	Emitter cut-off current	V _{EB} =6V ; I _C =0			0.1	mA
h _{FE}	DC current gain	I _C =10A ; V _{CE} =5V	10		30	
f _T	Transition frequency	I _C =2A ; V _{CE} =10V		20		MHz
C _{OB}	Output capacitance	I _E =0 ; V _{CB} =10V ; f=1MHz		260		pF

Silicon NPN Power Transistors

2SC3949

PACKAGE OUTLINE

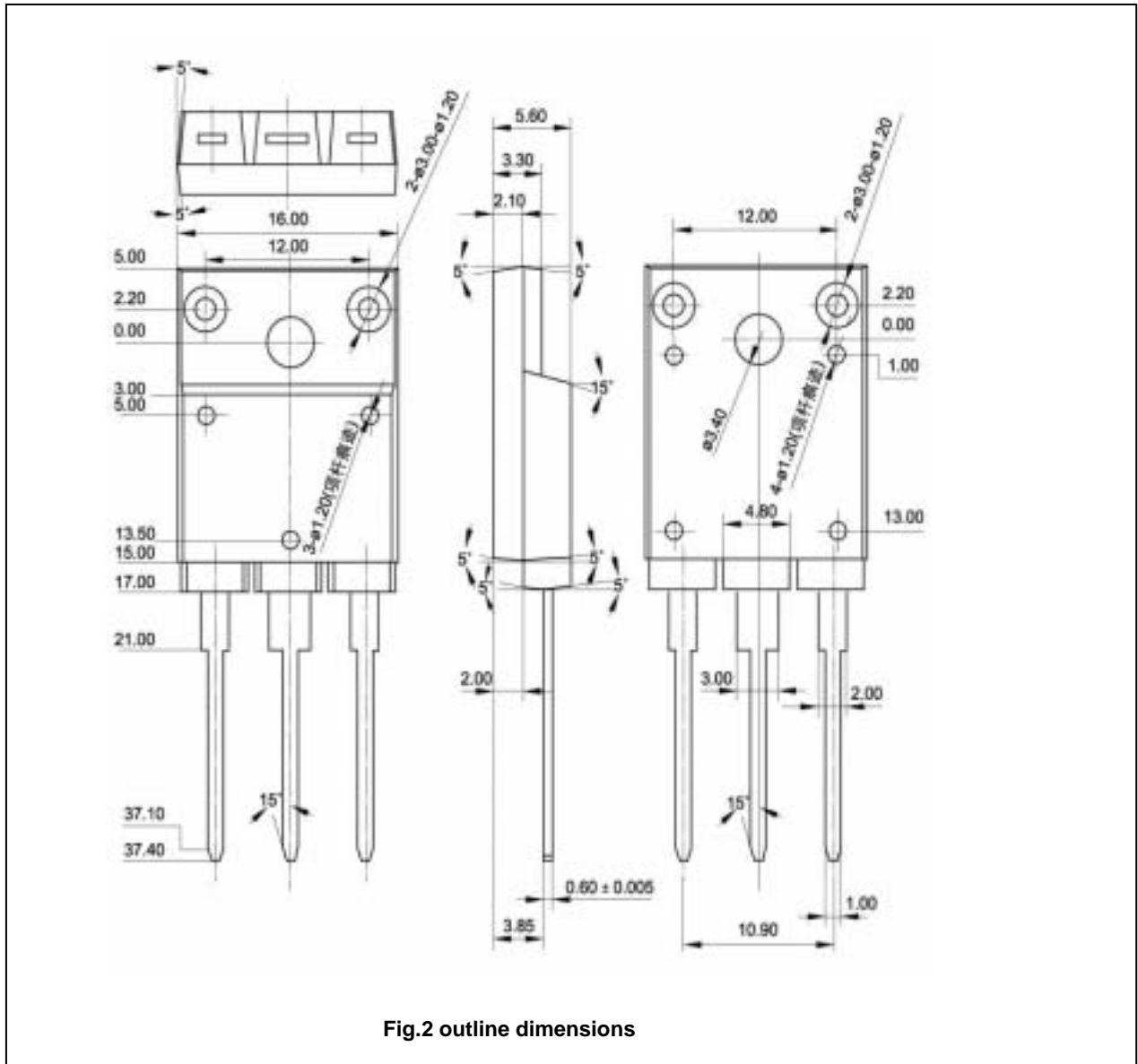

Fig.2 outline dimensions