



TAI-SAW TECHNOLOGY CO., LTD.

No. 3, Industrial 2nd Rd., Ping-Chen Industrial District,
Taoyuan, 324, Taiwan, R.O.C.

TEL: 886-3-4690038 FAX: 886-3-4697532

E-mail: tstsales@mail.taisaw.com Web: www.taisaw.com

Product Specifications Approval Sheet

Product Name: Duplexer 1960/2140MHz 60MHz BW SMD 2.0x1.6 mm

TST Parts No.: TF0088A

Customer Part No.: _____

Customer signature required
Company: _____
Division: _____
Approved by : _____
Date: _____

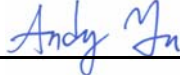
Checked by: _____ Andy Yu 

Approved by: _____ Bob Chau 

Date: _____ 2013, 11, 13

1. Customer signed back is required before TST can proceed with sample build and receive orders.
2. Orders received without customer signed back will be regarded as agreement on the specifications.
3. Any specifications changes must be approved upon by both parties and a new revision of specifications shall be released to reflect the changes



TAI-SAW TECHNOLOGY CO., LTD.

No. 3, Industrial 2nd Rd., Ping-Chen Industrial District,
Taoyuan, 324, Taiwan, R.O.C.

TEL: 886-3-4690038 FAX: 886-3-4697532

E-mail: tstsales@mail.taisaw.com Web: www.taisaw.com

SAW Duplexer 1960/2140MHz 60MHz BW SMD 2.0×1.6 mm

MODEL NO.: TF0088A

REV. No.: 1.0

A. MAXIMUM RATING:

1. Maximum Input Power: 29 dBm
2. DC voltage: 0 V
3. Operating Temperature: -20°C to +85°C
4. Storage Temperature: -40°C to +85°C

RoHS Compliant

Lead-free soldering

B. ELECTRICAL CHARACTERISTICS:

Tx to Ant		Specifications			
Parameters Description	Condition [MHz]	Unit	Minimum	Typical	Maximum
Insertion Loss	1920.0 ~ 1980.0	dB	-	1.5	1.8
Ripple	1920.0 ~ 1980.0	dB _{p-p}	-	0.4	1.0
VSWR of Ant Port	1920.0 ~ 1980.0	-	-	1.7	2.0
VSWR of Tx Port	1920.0 ~ 1980.0	-	-	1.8	2.1
Attenuation	1574.0 ~ 1577.0	dB	30	36	-
	2110.0 ~ 2170.0	dB	38	41	-
	2400.0 ~ 2500.0	dB	25	29	-
	3840.0 ~ 3960.0	dB	10	14	-

Ant to Rx		Specifications			
Parameters Description	Condition [MHz]	Unit	Minimum	Typical	Maximum
Insertion Loss	2110.0 ~ 2170.0	dB	-	1.6	2.2
Ripple	2110.0 ~ 2170.0	dB _{p-p}	-	0.5	1.0
VSWR of Ant Port	2110.0 ~ 2170.0	-	-	1.5	2.0
VSWR of Rx Port	2110.0 ~ 2170.0	-	-	1.5	2.0
Attenuation	1920.0 ~ 1980.0	dB	45	48	-
	1980.0 ~ 2025.0	dB	30	48	-
	2400.0 ~ 2500.0	dB	25	33	-
Amplitude balance(S ₃₁ /S ₄₁)	2110.0 ~ 2170.0	dB	-1.3	-0.2/+1.0	+1.3
Phase balance $\Phi(S_{31})-\Phi(S_{41})+180^\circ$	2110.0 ~ 2170.0	deg	-10	-5/+1	+10

Tx to Rx		Specifications			
Parameters Description	Condition [MHz]	Unit	Minimum	Typical	Maximum
Isolation in Tx Band	1920.0 ~ 1980.0	dB	55	59	-
Isolation in Rx Band	2110.0 ~ 2170.0	dB	44	47	-

Notes : (1) With Matching Network .

C. Frequency Characteristics :

Tx to Ant

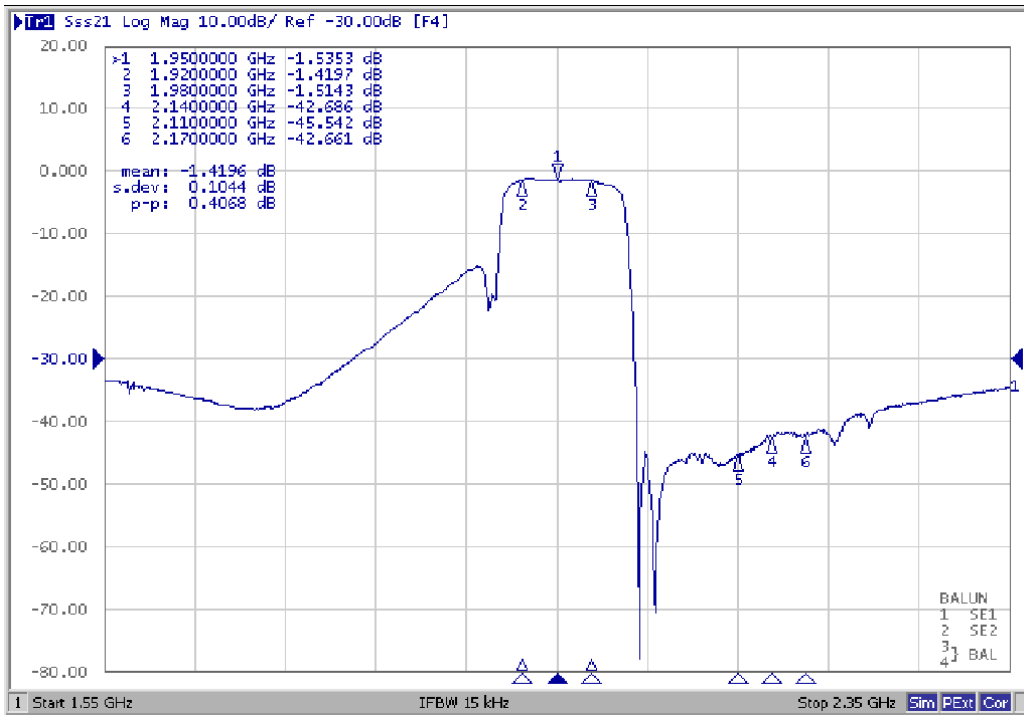

Ant to Rx

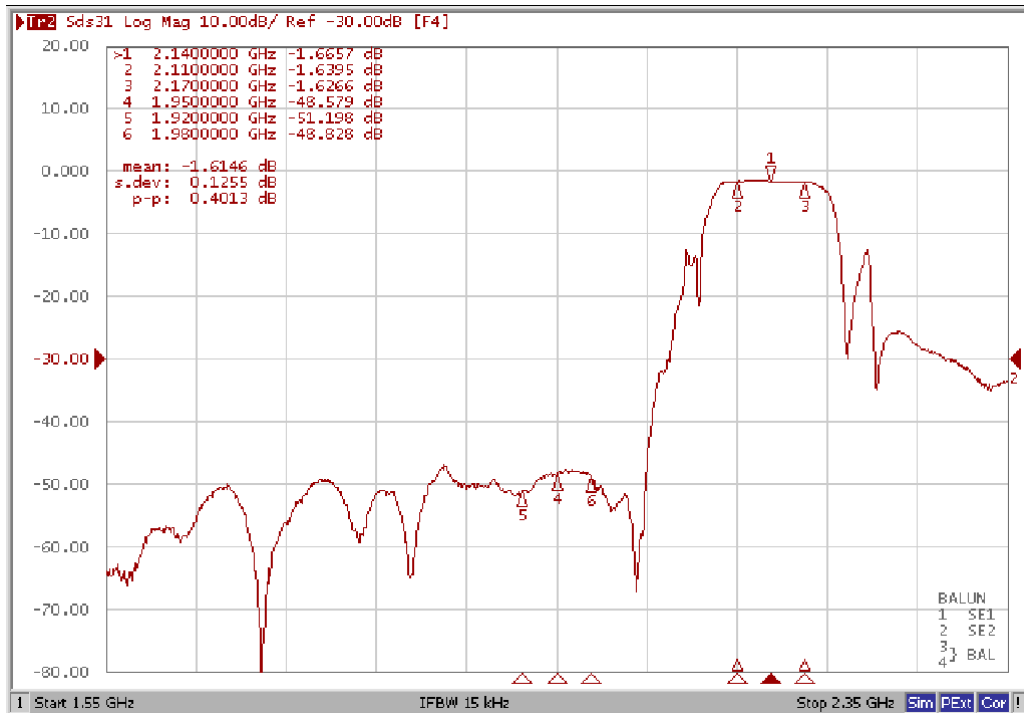

Isolation

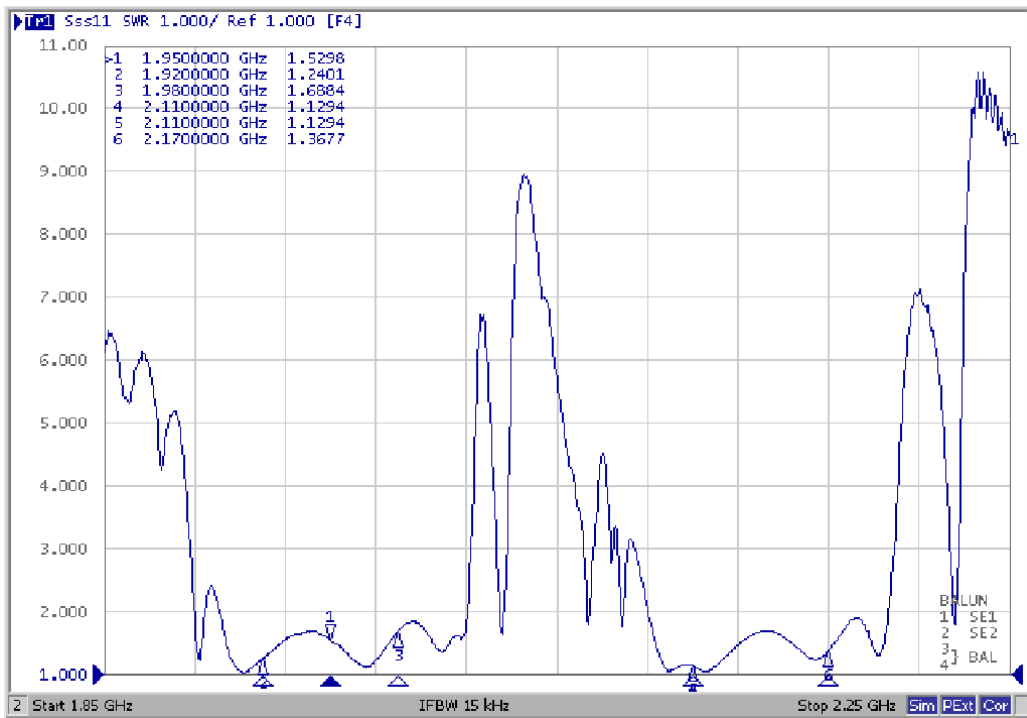

Ripple

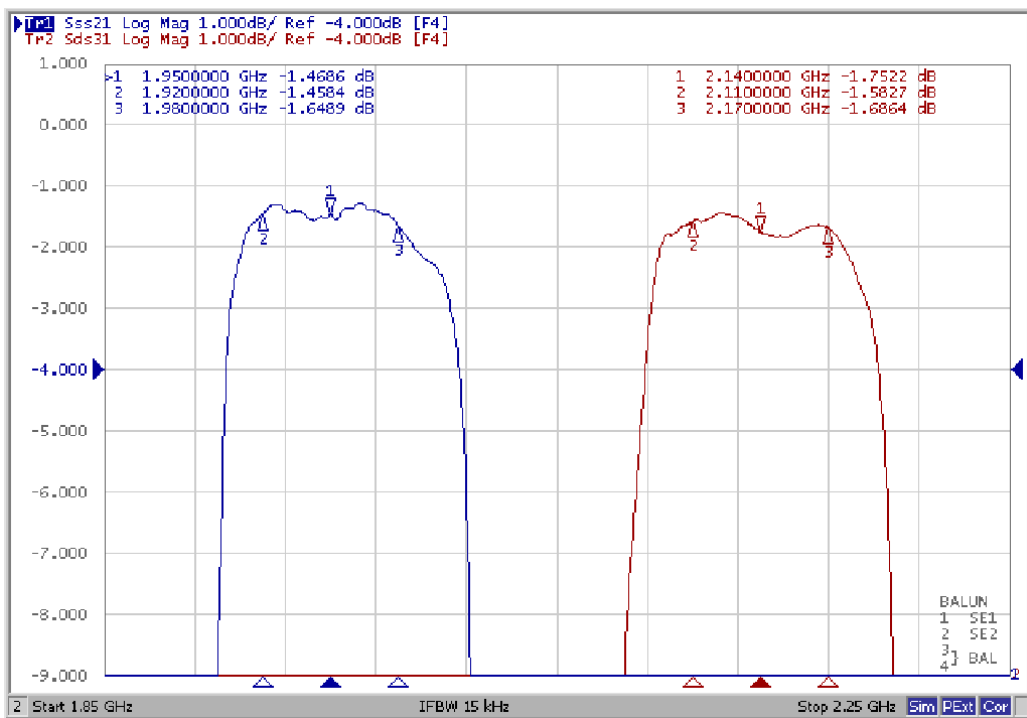

VSWR (Tx Port)

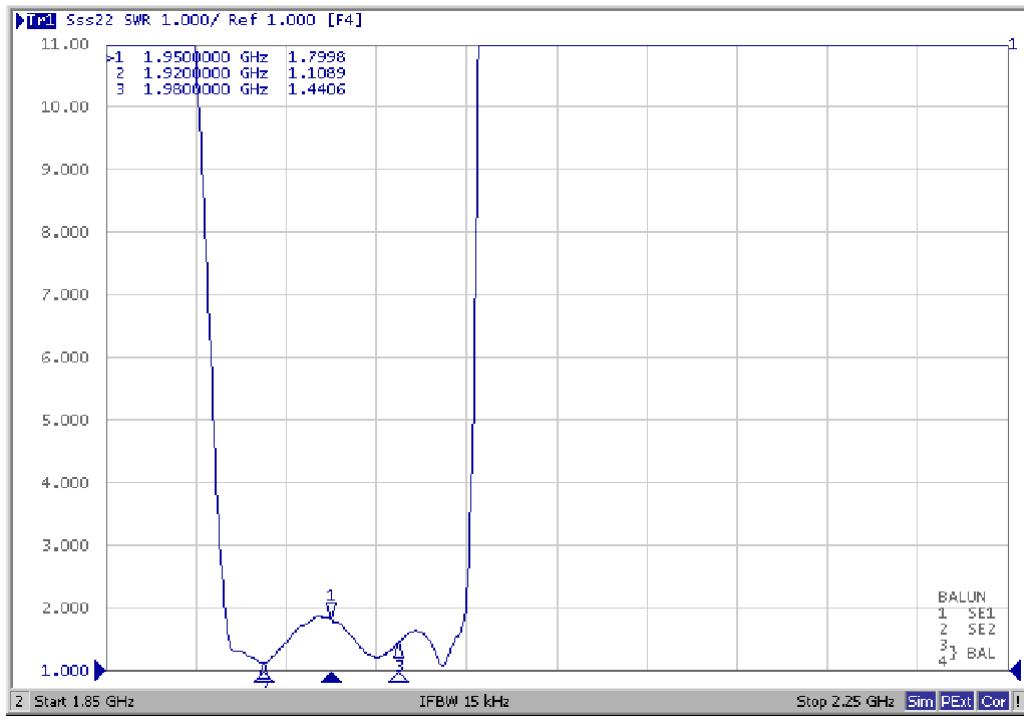

Smith Chart (Tx Port)

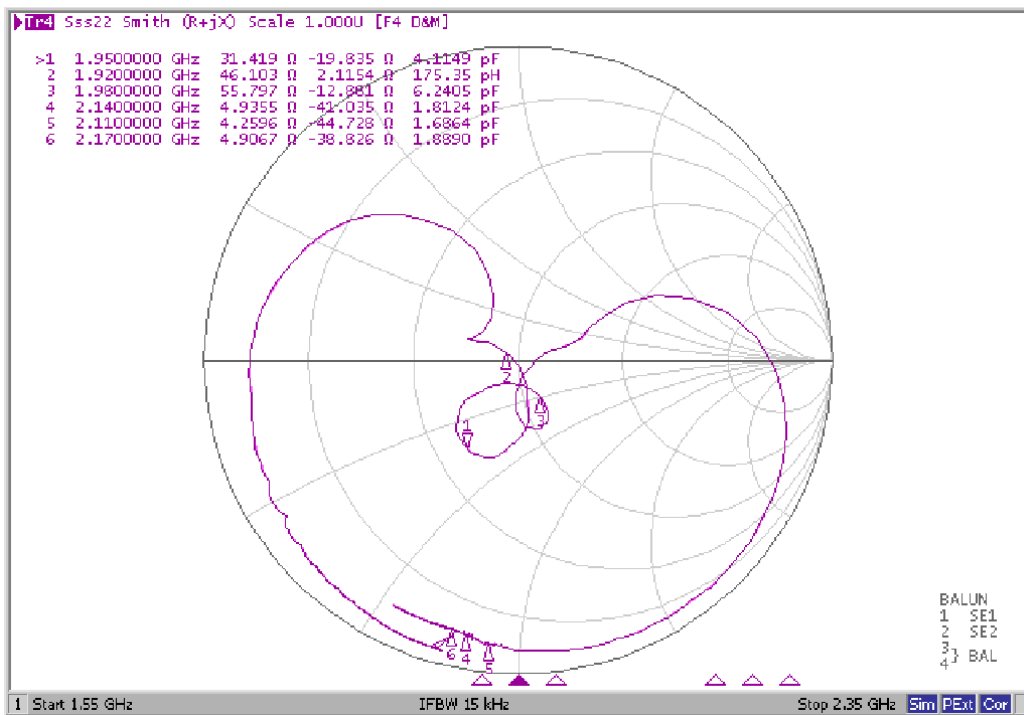

VSWR (Rx Port)



Smith Chart (Rx Port)

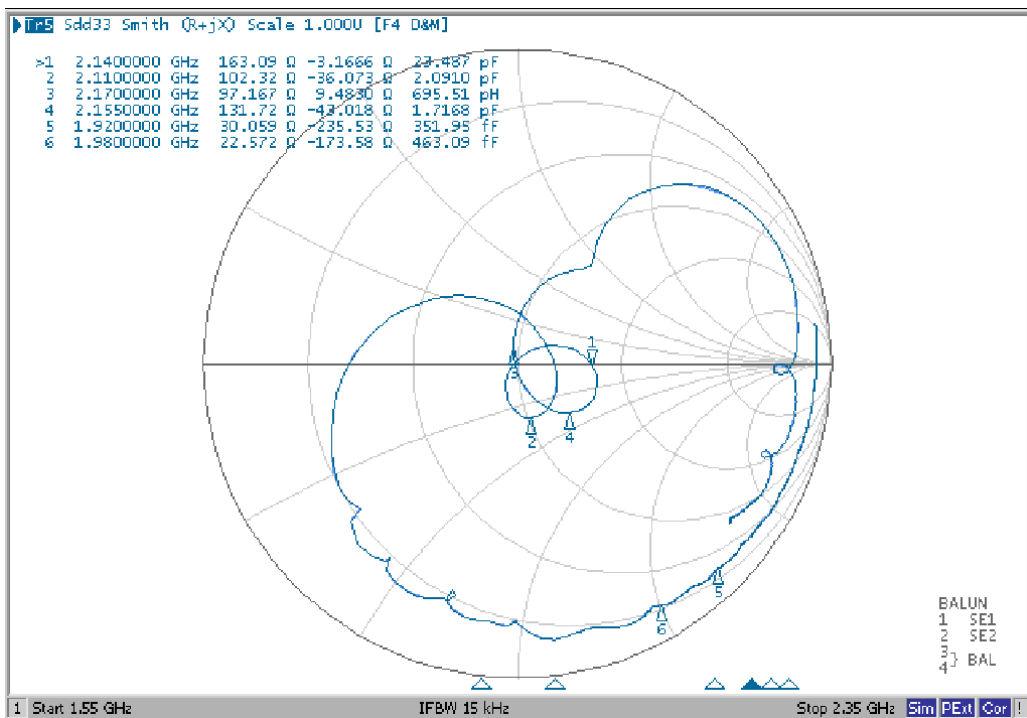

VSWR (ANT Port)

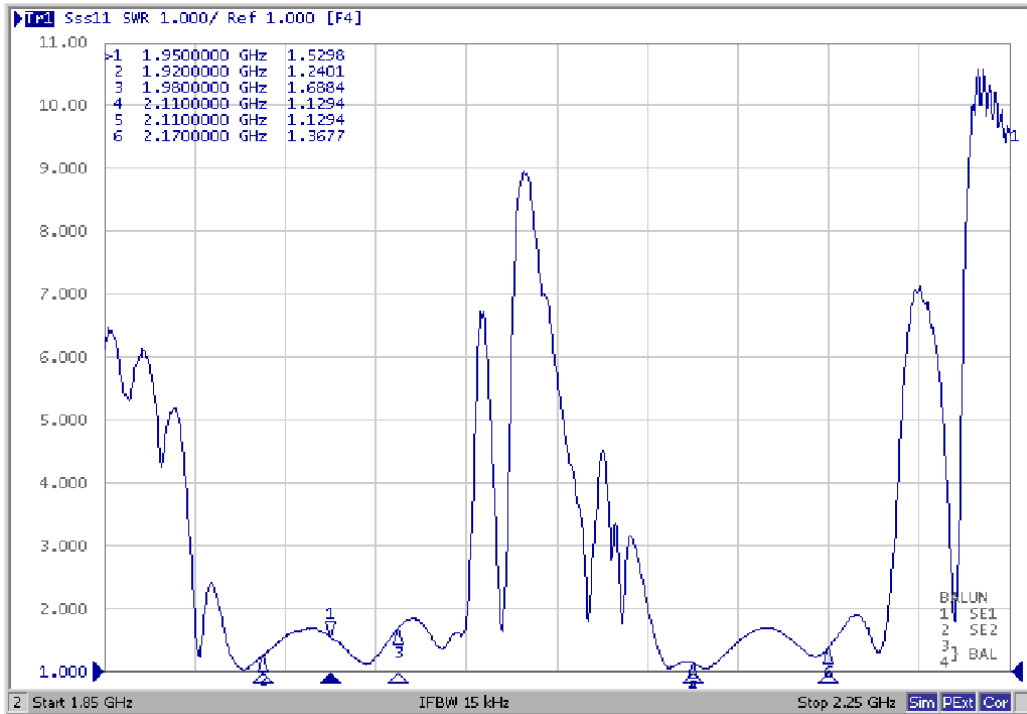

Smith Chart (ANT Port)

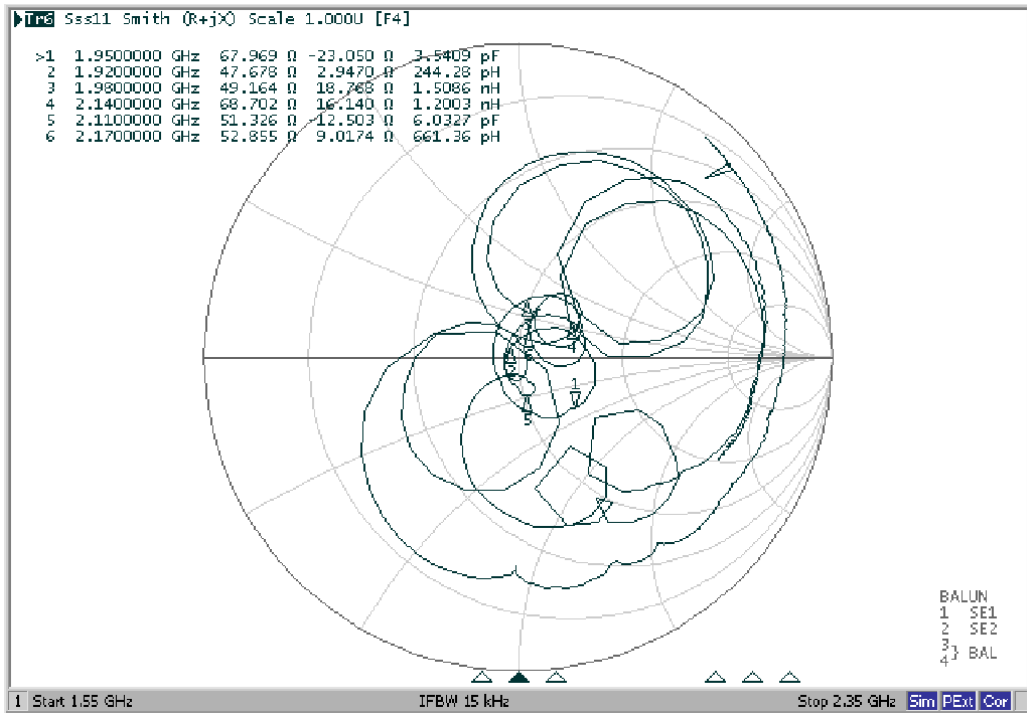

Wide Span

Tx

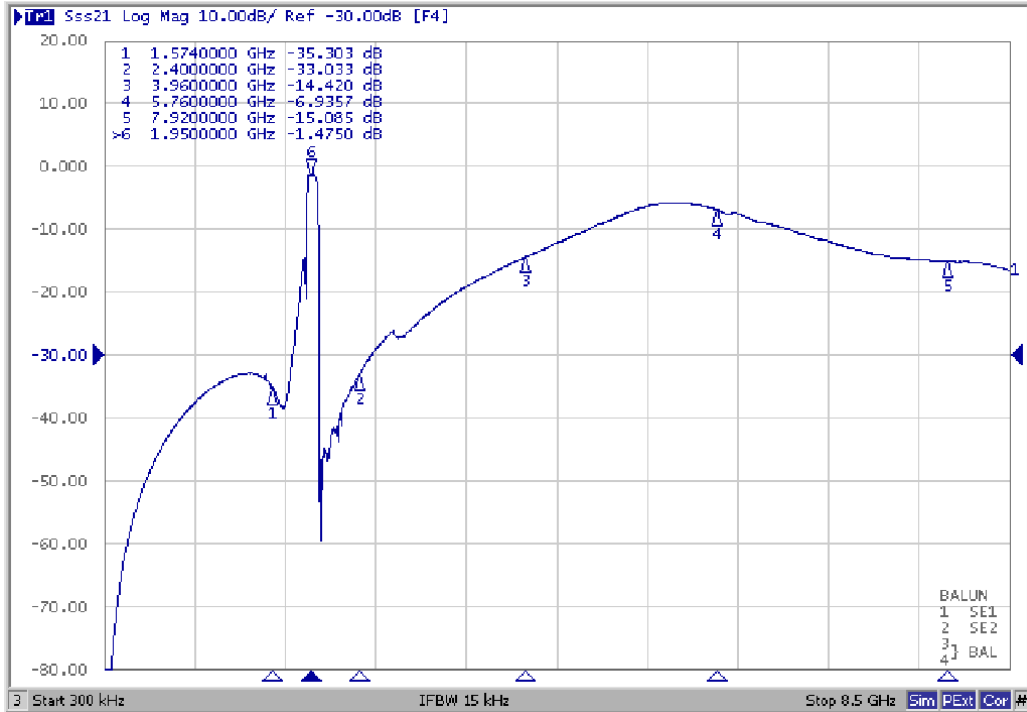

Rx

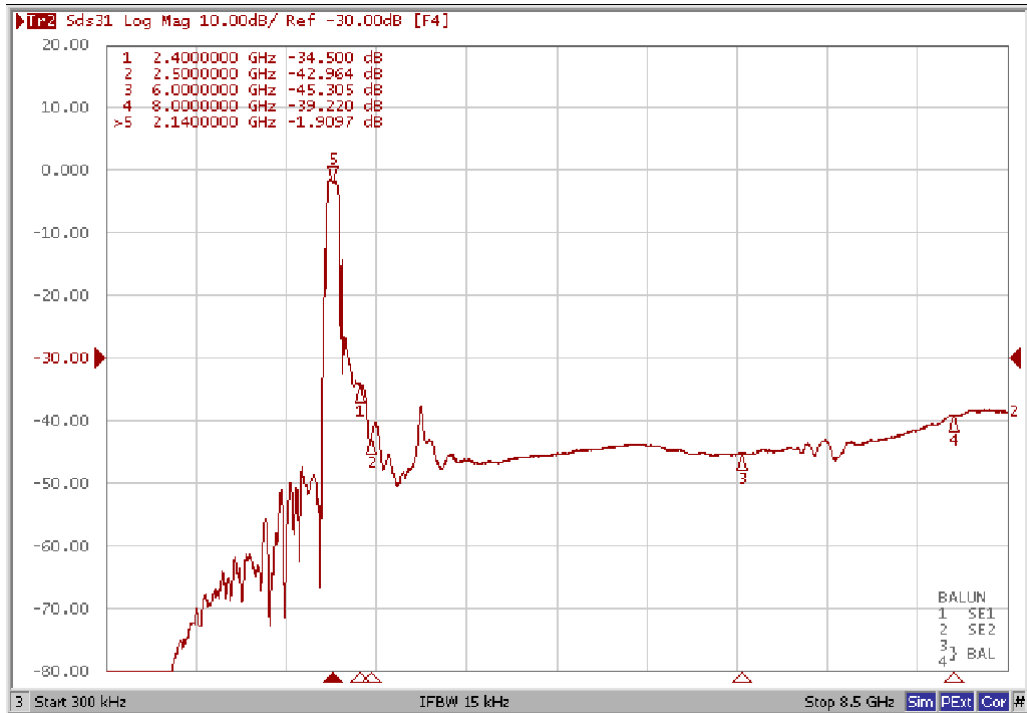

Amplitude balance of Ant to Rx+/Rx-

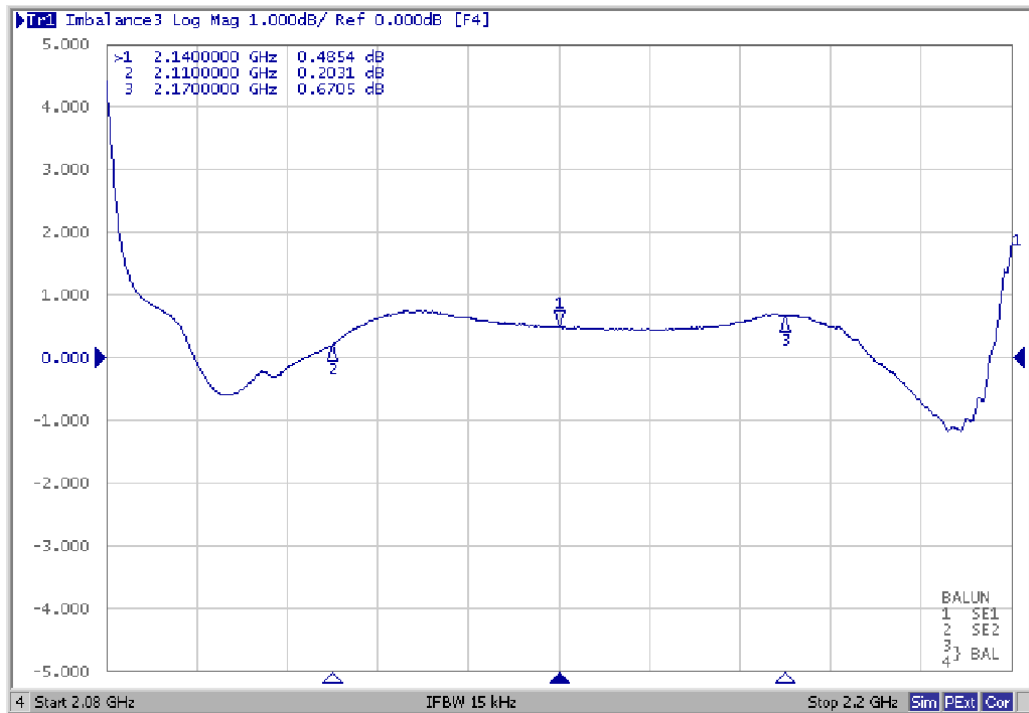

Phase balance of Ant to Rx+/Rx-

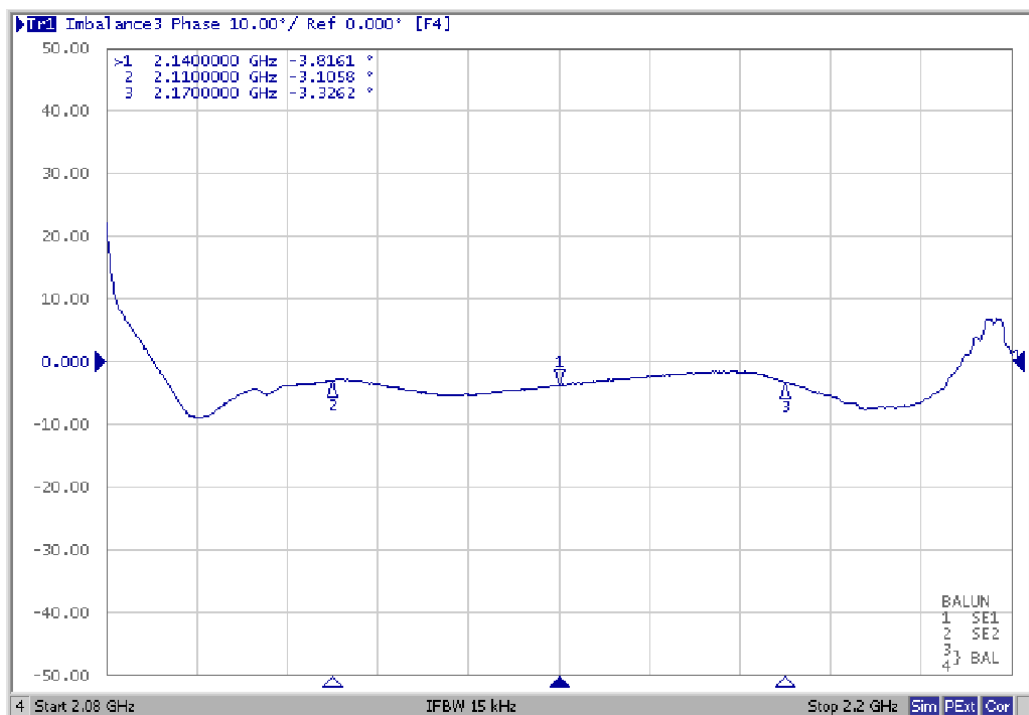

D. MEASUREMENT CIRCUIT:

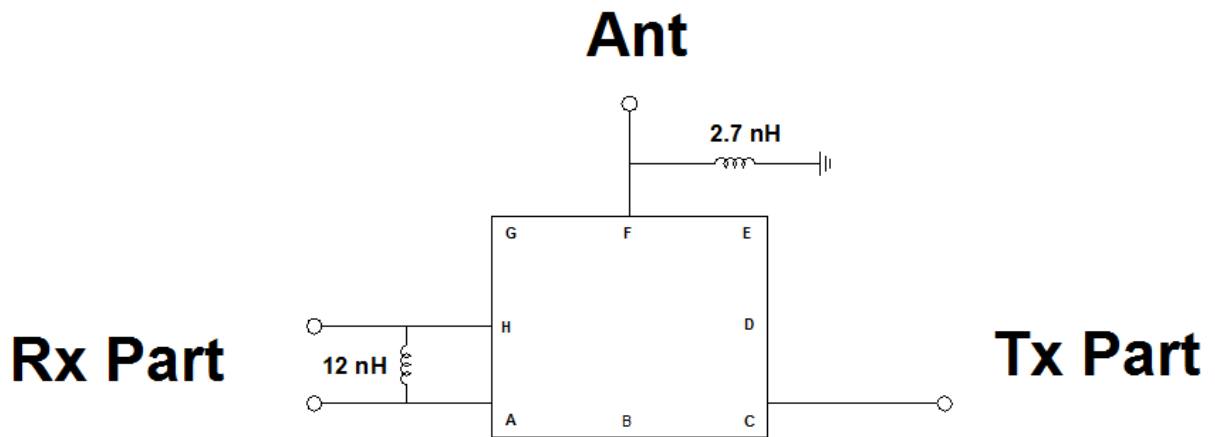

E. OUTLINE DRAWING: _

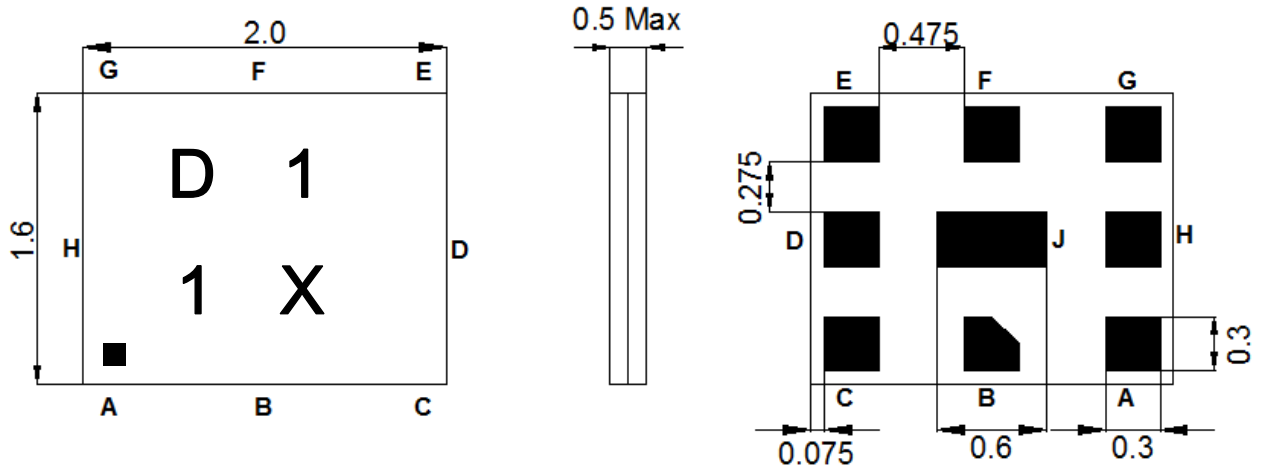

Marking Descriptions	
D	Duplexer Application
1	Band Class
1	Series Number
X	Date Code(Year+Month)

Pin Description	
B,D,E,G,J	Ground
F	Ant
C	Tx (1950.0MHz)
A,H	Rx (2140.0MHz)

E. PACKING:

1. REEL DIMENSION

(Please refer to FR-75D10 for packing quantity)

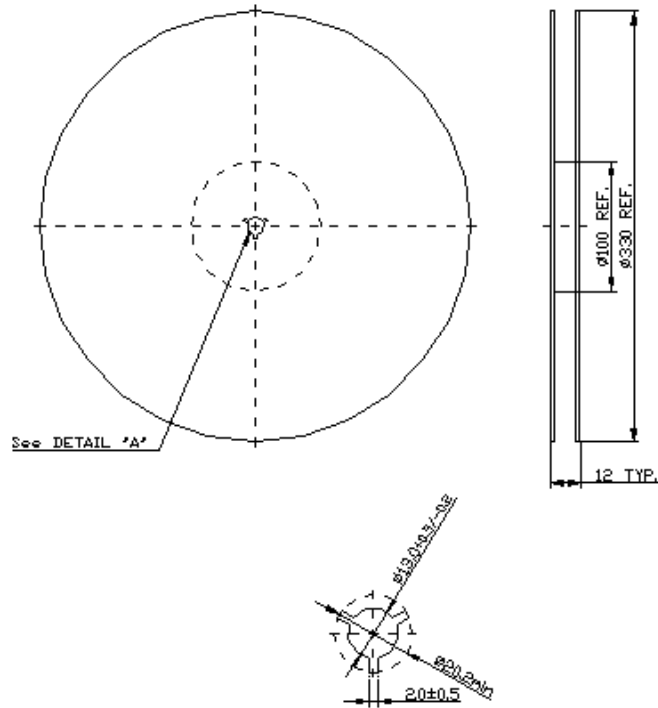

2. TAPE DIMENSION

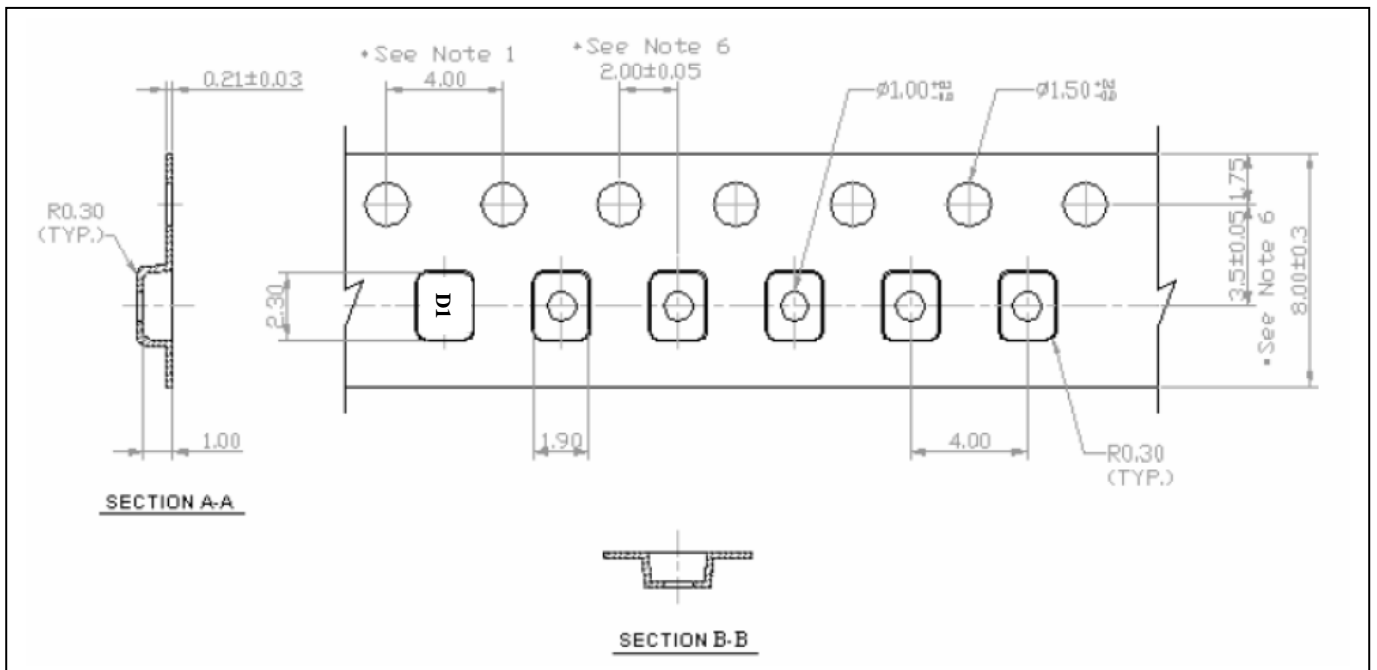

F. RECOMMENDED REFLOW PROFILE :

