



M.S.KENNEDY CORP.

# FAST SETTLING HIGH VOLTAGE AMPLIFIER

# 612

4707 Dey Road Liverpool, N.Y. 13088

(315) 701-6751

**FEATURES:**

- Ultra Low Quiescent Current -  $\pm 13\text{mA}$  for High Voltage
- 140V Peak to Peak Output Voltage Swing
- Slew Rate -  $5000\text{V}/\mu\text{S}$  Typical
- Settling Time to 0.05% -  $1.5\mu\text{S}$  Max.
- Input Offset Voltage Only -  $\pm 5\text{mV}$  Max.
- Output Current - 250mA Peak
- Adjustable VHV Power Supply Minimizes Power Dissipation
- Compact Package Offers Superior Power Dissipation Capability
- Contact MSK for MIL-PRF-38534 Qualification Status

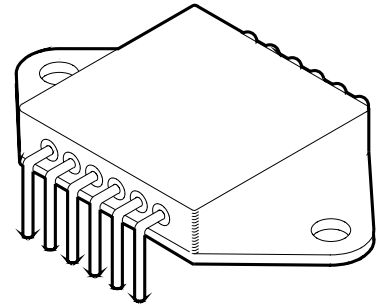

**DESCRIPTION:**

The MSK 612 is a high voltage fast settling amplifier designed to provide large voltage swings at high slew rates in wideband systems. The true inverting op-amp topology employed in the MSK 612 provides excellent D.C. specifications such as input offset voltage and input bias current. These attributes are important in amplifiers that will be used in high gain configurations since the input error voltages will be multiplied by the system gain. The MSK 612 achieves impressive settling time specifications by employing a feed forward A.C. path through the amplifier, however, the device is internally configured in inverting mode to utilize this benefit. Internal compensation for gains of  $-5\text{V}/\text{V}$  or greater keeps the MSK 612 stable in this range. The MSK 612 is packaged in a space efficient, hermetically sealed, 12 pin power dual in line package that has a high thermal conductivity for efficient device cooling.

**EQUIVALENT SCHEMATIC**

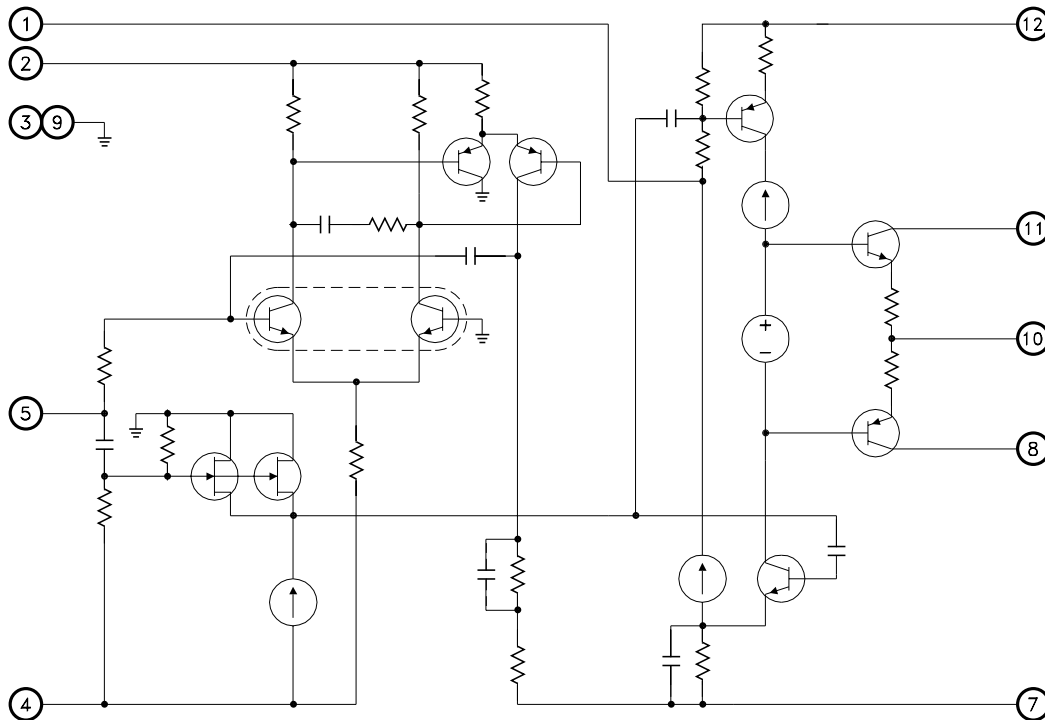

**TYPICAL APPLICATIONS**

- Fast Settling High Voltage Amplifier
- High Resolution CRT Monitor
- Ultra High Performance Video Processing
- CRT Beam Intensity Control
- Varactor Tuned VCO Driver
- Automatic Test Equipment

**PIN-OUT INFORMATION**

1	COMP	12	+VHV
2	+VCC	11	+VSC
3	GROUND	10	OUTPUT
4	-VCC	9	CASE/GROUND
5	-INPUT	8	-VSC
6	NO CONNECTION	7	-VHV

## ABSOLUTE MAXIMUM RATINGS

⑥

$\pm V_{HV}$	Supply Voltage . . . . .	$\pm 80VDC$	$T_{ST}$	Storage Temperature Range	-65 °C to +150 °C
$\pm V_{IN}$	Input Voltage Range . . . . .	$\pm VCC$	$T_{LD}$	Lead Temperature Range . . . . .	300 °C
$\pm V_{CC}$	Supply Voltage (Input Stage) . . . . .	$\pm 18VDC$		(10 Seconds)	
$\theta_{JC}$	Thermal Resistance . . . . .	30 °C/W	$T_C$	Case Operating Temperature	
	(Output Devices)			MSK612 . . . . .	-40 °C to +85 °C
				MSK612B/E . . . . .	-55 °C to +125 °C
			$T_J$	Junction Temperature . . . . .	150 °C

## ELECTRICAL SPECIFICATIONS

Parameter	Test Conditions ①	Group A Subgroup	MSK 612B/E			MSK 612			Units
			Min.	Typ.	Max.	Min.	Typ.	Max.	
<b>STATIC</b>									
Quiescent Current	$V_{IN} = 0 @ +V_{CC}$	1,2,3	-	1.0	3.5	-	1.0	4.0	mA
	$V_{IN} = 0 @ -V_{CC}$	1,2,3	-	12	30	-	15	32	mA
	$V_{IN} = 0 @ +V_{HV}$	1,2,3	-	12	20	-	12	22	mA
	$V_{IN} = 0 @ -V_{HV}$	1,2,3	-	12	20	-	12	22	mA
Input Offset Voltage	$V_{IN} = 0$	1	-	$\pm 0.2$	$\pm 5.0$	-	$\pm 1.0$	$\pm 10$	mV
		2,3	-	$\pm 1.0$	$\pm 10$	-	$\pm 2.0$	-	mV
Input Bias Current		1	-	50	500	-	50	750	nA
		2,3	-	100	750	-	100	-	nA
Input Offset Voltage Drift ②	$V_{IN} = 0$	2,3	-	$\pm 5$	$\pm 50$	-	$\pm 5$	-	$\mu V/^\circ C$
Power Supply Range ②	$\pm V_{CC}$	-	$\pm 12$	$\pm 15$	$\pm 18$	$\pm 12$	$\pm 15$	$\pm 18$	V
	$\pm V_{HV}$	-	$\pm 50$	$\pm 65$	$\pm 80$	$\pm 50$	$\pm 65$	$\pm 80$	V
<b>DYNAMIC CHARACTERISTICS</b>									
Output Voltage Swing	$f = 1KHz$	4	$\pm 50$	$\pm 58$	-	$\pm 50$	$\pm 58$	-	V
Peak Output Current ②	$f = 1KHz$	-	$\pm 200$	$\pm 250$	-	$\pm 200$	$\pm 250$	-	mA
Full Power Output ②	$V_o = \pm 50V$	-	5	12	-	4	12	-	MHz
Unity Gain Bandwidth ②	$V_o = \pm 1.0V$	-	80	100	-	80	100	-	MHz
Slew Rate	$V_o = \pm 50V$	4	2000	5000	-	2000	5000	-	V/ $\mu S$
Voltage Gain ②	$V_o = \pm 50V$ $f = 1KHz$	4	90	100	-	90	100	-	dB
Settling Time to 1% ②	$A_v = -10V/V$ $V_o = \pm 50V$	-	-	100	-	-	100	-	nS
Settling Time to 0.1% ②	$A_v = -10V/V$ $V_o = \pm 50V$	-	-	400	-	-	400	-	nS
Settling Time to 0.05%	$A_v = -10V/V$ $V_o = \pm 50V$	4	-	750	1.5	-	750	1.6	$\mu S$

### NOTES:

- ① Unless otherwise specified,  $\pm V_{CC} = \pm 15VDC$ ,  $\pm V_{HV} = \pm 65VDC$ ,  $C_L = 8pF$  (probe capacitance) and  $A_v = 10V/V$ .
- ② This parameter is guaranteed by design but not tested. Typical parameters are representative of actual device performance but are for reference only.
- ③ Industrial grade and "E" suffix devices shall be tested to subgroups 1 and 4 unless otherwise specified.
- ④ Military grade devices ('B' suffix) shall be 100% tested to subgroups 1,2,3 and 4.
- ⑤ Subgroup 1,4  $T_A = T_C = +25^\circ C$   
 Subgroup 2,5  $T_A = T_C = +125^\circ C$   
 Subgroup 3,6  $T_A = T_C = -55^\circ C$
- ⑥ Continuous operation at or above absolute maximum ratings may adversely affect the device performance and/or life cycle.

## APPLICATION NOTES

### FEED FORWARD TOPOLOGY

The MSK 612 employs a circuit topology known as "feed forward". This inverting configuration allows the user to realize the excellent D.C. input characteristics of a differential amplifier without losing system bandwidth. The incoming signal is split at the input into its A.C. and D.C. component. The D.C. component is allowed to run through the differential amplifier where any common mode noise is rejected. The A.C. component is "fed forward" to the output section through a very high speed linear amplifier where it is mixed back together with the D.C. component. The result is an amplifier with most of the benefits of a differential amplifier without the loss in system bandwidth.

### INTERNAL COMPENSATION

Since the MSK 612 is a high voltage amplifier, it is commonly used in circuits employing large gains. Therefore, the internal compensation was chosen for gains of  $-5V/V$  or greater. In circuits running at gains of less than  $-5V/V$ , the user can further compensate the device by adding compensation networks at the input or feedback node. Pin 1 (comp) should be bypassed with a  $1.0\mu F$  ceramic capacitor to  $+V_{HV}$  for all applications.

### HIGH VOLTAGE SUPPLIES

The positive and negative high voltage supplies on the MSK 612 can be adjusted to reduce power dissipation. The output of the MSK 612 will typically swing to within  $8V$  of either high voltage power supply rail. Therefore, if the system in question only needs the output of the amplifier to swing  $\pm 40V$  peak, the power supply rails could be set to  $\pm 50V$  safely. For best performance, the minimum value of  $\pm V_{HV}$  should be  $\pm 50V_{DC}$ . Unbalanced power supply rails are also allowed as long as one or the other is not decreased to below  $30V$  or above  $80V$ . The high voltage and low voltage power supplies should be decoupled as shown in Figure 1.

### TRANSITION TIMES

Transition time optimization of the MSK 612 follows the same basic rules as most any other amplifier. Best transition times will be realized with minimum load capacitance, minimum external feedback resistance and lowest circuit gain. Transition times will degrade if the output is driven too close to either supply rail. Feedback and input resistor values will affect transition time as well. See Figure 1 and Table 1 for recommended component values.

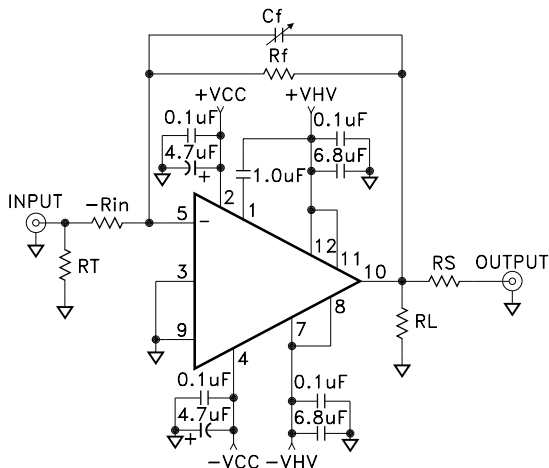

Figure 1

VOLTAGE GAIN	$-R_{IN}$	$R_F$	$C_F$
$-10V/V$	$1K\Omega$	$10K\Omega$	$0.5-5pF$
$-20V/V$	$249\Omega$	$5K\Omega$	N/A
$-50V/V$	$100\Omega$	$5K\Omega$	N/A

Table 1

### CURRENT LIMIT

Figure 2 is a possible active short circuit protection scheme for the MSK 612. The following formula may be used for setting current limit:

$$\text{Current Limit} \approx 0.6V / R_{sc}$$

$R_{BASE}$  must be selected based on the value of  $\pm V_{HV}$  as follows:

$$R_{BASE} = ((+V_{HV} - (-V_{HV})) - 1.2V) / 4mA$$

This formula guarantees that Q2 and Q4 will always have sufficient base current to be in operation. This circuit can be made tolerant of high frequency output current spikes with the addition of  $C_{sc}$ . The corresponding time constant would be:

$$T = (R_{sc})(C_{sc})$$

A common value for  $C_{sc}$  is approximately  $1000pF$ . If current limit is unnecessary, short pin 7 to pin 8 and pin 11 to pin 12 as shown in Figure 1.

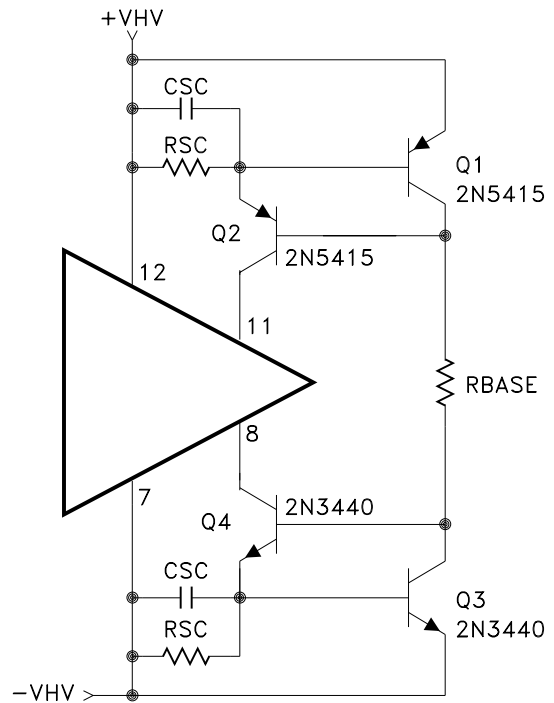
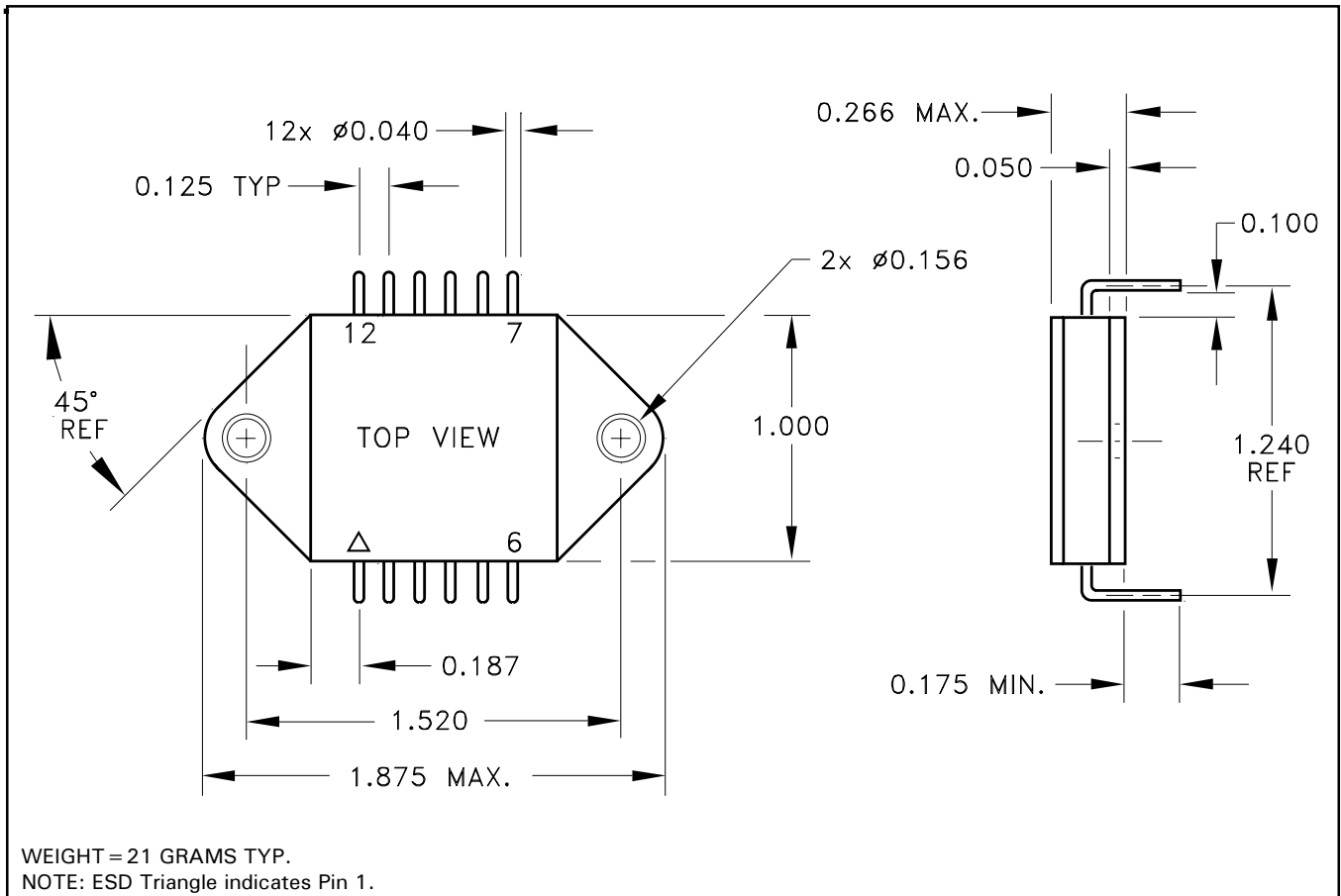

Figure 2

# MECHANICAL SPECIFICATIONS



ALL DIMENSIONS ARE  $\pm 0.010$  INCHES UNLESS OTHERWISE LABELED

## ORDERING INFORMATION

Part Number	Screening Level
MSK612	Industrial
MSK612E	Extended Reliability
MSK612B	Mil-PRF-38534 Class H

M.S. Kennedy Corp.  
4707 Dey Road, Liverpool, New York 13088  
Phone (315) 701-6751  
FAX (315) 701-6752  
www.mskennedy.com

The information contained herein is believed to be accurate at the time of printing. MSK reserves the right to make changes to its products or specifications without notice, however, and assumes no liability for the use of its products. Please visit our website for the most recent revision of this datasheet. Contact MSK for MIL-PRF-38534 qualification status.