

# NCP6868

## Product Preview

### 2.5 A Boost Regulator with Bypass Function

The NCP6868 is a synchronous boost converter. It is designed primarily to boost new generation low-voltage Li-Ion batteries (silicon anode-like) embedded into cell and smart phones. The objective is to guarantee a minimum output voltage even in the case for which the battery voltage is below the minimum voltage required by the system. The device features a Bypass mode coupled with a Boost mode. It is capable to drive a continuous load up to 2.5 A and it operates at a switching frequency of 2.5 MHz. An I<sup>2</sup>C serial control can also be enabled for configuring the output voltage and peak current limit. The NCP6868 is available in a space saving, low profile 1.8 × 1.8 mm CSP-16 package.

#### Features

- 2.35 V to 5.5 V Input Voltage
- Fixed or Programmable V<sub>OUT</sub>: from 2.85 V Up to 5.3 V
- Bypass Operation when V<sub>IN</sub> is Above or Close to V<sub>OUT</sub>
- Few External Components & 0.47 μH Inductor
- High Efficiency Up to 98%
- Output Current Up to 2.5 A Continuous (V<sub>IN</sub> = 2.6 V, V<sub>OUT</sub> = 3.5 V) and up to 4 A Peak Current
- Inductor Peak Current up to 9.0 A
- Forced Bypass Option through  $\overline{BP}$  Pin
- Low Quiescent Current: 50 μA
- Voltage Control Pin (VSEL) to Precisely Adjust V<sub>OUT</sub>
- I<sup>2</sup>C Serial Control as a Software-Mode Option to Program Output Voltage and Peak Current Limit
- Soft-Start Function (SS) to Limit Inrush Current
- Current Limitation to Protect Against Short Circuit
- Thermal Limit Protection
- Small 1.8 × 1.8 mm / 0.4 mm Pitch CSP Package
- These Devices are Pb-Free and are RoHS Compliant

#### Typical Applications

- Boost Converters for New Generation Low-Voltage Li-Ion Batteries
- USB OTG (On-The-Go)
- 3G/4G – LTE RF PA
- Cell Phones, Smart Phones, Phablets, Tablets & Webtablets

This document contains information on a product under development. ON Semiconductor reserves the right to change or discontinue this product without notice.



ON Semiconductor®

[www.onsemi.com](http://www.onsemi.com)



WLCSP16  
CASE 567JU

#### MARKING DIAGRAM

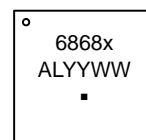

6868x = Specific Device Code  
x = P: NCP6868P  
B: NCP6868V315  
C: NCP6868V330  
E: NCP6868E315  
A = Assembly Location  
L = Wafer Lot  
YY = Year  
WW = Work Week  
▪ = Pb-Free Package

#### ORDERING INFORMATION

See detailed ordering and shipping information on page 27 of this data sheet.

# NCP6868

## TYPICAL APPLICATION

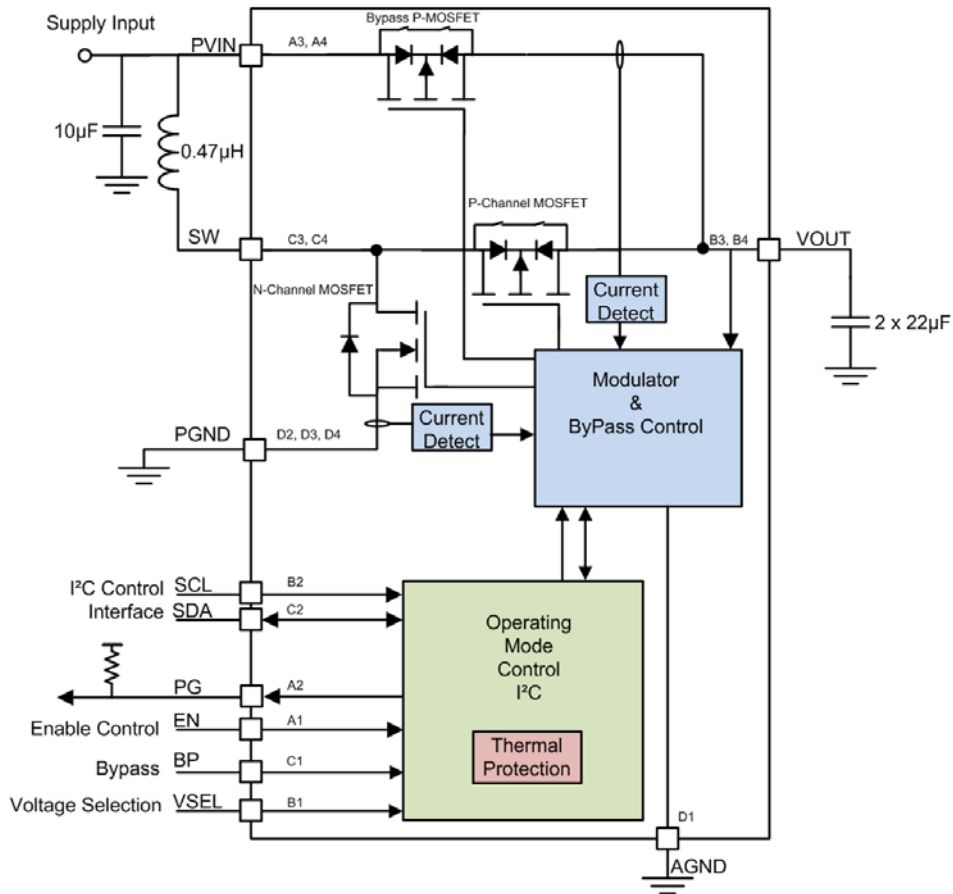

Figure 1. Application Block Diagram

## PIN OUT

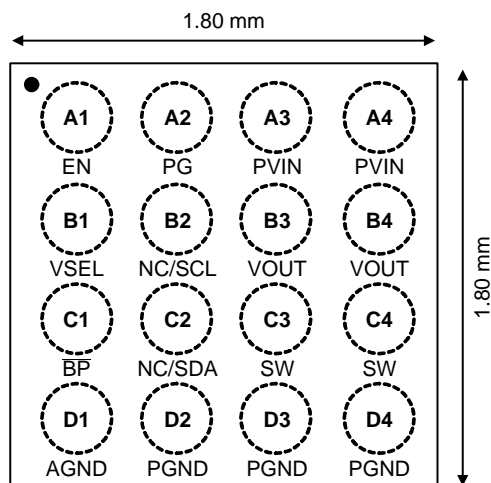

Figure 2. Pin Out (Top View)

# NCP6868

**Table 1. PIN FUNCTION DESCRIPTION**

Pin	Name	Type	Description
A1	EN	Input	Enable Control. Active high will enable the part. There is an internal pull down resistor on this pin.
A2	PG	Input/Output	Interrupt Output pin active Low (Open drain); PG is pulled low if a PG event is detected that is output out of regulation, over-voltage, overload, UVLO or TWRN protection is activated. PG is pulled-up High when EN is Low.
A3–A4	P <sub>VIN</sub>	Power Input	DCDC input power connected to a Li-Ion battery. This pin must be decoupled to ground by a 10 $\mu$ F and 1 $\mu$ F ceramic capacitors. These capacitors should be placed as close as possible to this pin.
B1	VSEL	Input	Output Voltage Select. This pin can be used to select the voltage when the device operates in boost mode. VSEL = Low, Low voltage target selected; VSEL = High, High voltage target selected. There is an internal pull-down resistor on this pin.
B2	MODE/SCL	Input	MODE: B2 pin is configured as a MODE pin when the I <sup>2</sup> C interface is disabled and the device output voltage is fixed. When MODE = Low the device is operating in auto mode. This pin must be set Low during device start-up. When MODE = High the device is operating in forced CCM mode. SCL: I <sup>2</sup> C interface Clock line when the I <sup>2</sup> C interface is enabled. There is an internal pull down resistor on this pin.
C2	NC/SDA	Ground or Input/Output	NC: For device without I <sup>2</sup> C interface activated, connect this pin to AGND. SDA: Bidirectional data line of the I <sup>2</sup> C bus.
D1	AGND	Ground	Analog Ground. Analog and digital circuit blocks' ground. This pin must be connected to the system ground.
B3–B4	V <sub>OUT</sub>	Power Output	Output voltage. Connect output capacitors as close as possible to the device.
C1	$\overline{BP}$	Input	Bypass pin. Active Low. This pin is used to force the device into the bypass mode. In forced Bypass mode, both Bypass P-MOSFET and P-Channel MOSFET (see Figure 1) are turned ON and N-Channel MOSFET (see Figure 1) is turned OFF. There is an internal pull-up resistor on this pin.
C3–C4	SW	Power	DC-DC Switch Power pin. This pin connects the power transistors to one end of the inductor. Typical application (2.5 MHz) uses a 0.470 $\mu$ H inductor; refer to application section for more information.
D2–D4	PGND	Ground	Power Ground. This pin is the power ground and carries the high switching current. High quality ground must be provided to prevent noise spikes. To avoid high-density current flow in a limited PCB track, a local ground plane that connects all PGND pins together is recommended. Analog and power grounds should only be connected together in one location through a printed trace.

**Table 2. MODES OF OPERATION**

EN	$\overline{BP}$	Device State
0	X	All bias circuits are off and the device is in shutdown mode. During shutdown, current flow is prevented from P <sub>VIN</sub> to V <sub>OUT</sub> and from SW to V <sub>OUT</sub> .
1	0	The device is active and forced in bypass mode. A short circuit protection is embedded in order to prevent the output voltage going to low.
1	1	The device will switch between Boost mode and Bypass mode automatically.

# NCP6868

**Table 3. MAXIMUM RATINGS**

Rating	Symbol	Value	Unit
Analog and Power Pins: P <sub>VIN</sub> , SW	V <sub>A</sub>	-0.3 to +6.0	V
V <sub>OUT</sub> Pin	V <sub>OUT</sub>	-0.3 to +6.0	V
Digital pins: EN, VSEL, $\overline{\text{BP}}$ , MODE/SCL, SDA, PG: Input Voltage Input Current	V <sub>DG</sub> I <sub>DG</sub>	-0.3 to V <sub>A</sub> + 0.3 ≤ 6.0 10	V mA
Operating Ambient Temperature Range	T <sub>A</sub>	-40 to +85	°C
Operating Junction Temperature Range (Note 1)	T <sub>J</sub>	-40 to +125	°C
Storage Temperature Range	T <sub>STG</sub>	-65 to + 150	°C
Maximum Junction Temperature	T <sub>JMAX</sub>	-40 to +150	°C
Thermal Resistance Junction-to-Ambient (Note 2)	R <sub>θJA</sub>	78	°C/W
ESD, Electrostatic Discharge Protection, Human Body Model (Note 3) Charged Device Model	HBM CDM	2 1	kV
Latch Up Current: (Note 4) Digital Pins All Other Pins	I <sub>LU</sub>	10 100	mA
Moisture Sensitivity (Note 5)	MSL	Level 1	

Stresses exceeding those listed in the Maximum Ratings table may damage the device. If any of these limits are exceeded, device functionality should not be assumed, damage may occur and reliability may be affected.

- The thermal shutdown set to 150°C (typical) avoids potential irreversible damage on the device due to power dissipation.
- The Junction-to-Ambient and Junction-to-Board thermal resistances are a function of Printed Circuit Board (PCB) layout and application. These data are measured using 4-layer PCBs (2s2p). For a given ambient temperature T<sub>A</sub> it has to be pay attention to not exceed the max junction temperature T<sub>JMAX</sub>.
- This device series contains ESD protection and passes the following ratings:  
Human Body Model (HBM) ±2.0 kV per JEDEC standard: JESD22-A114.  
Machine Model (MM) ±150 V per JEDEC standard: JESD22-A115.
- Latch up current per JEDEC standard: JESD78 class II.
- Moisture Sensitivity Level (MSL): 1 per IPC/JEDEC standard: J-STD-020A.

**Table 4. RECOMMENDED OPERATING CONDITIONS**

Symbol	Parameter	Conditions	Min	Typ	Max	Unit	
P <sub>VIN</sub>	Power Supply (Note 6)		2.35	-	5.5	V	
V <sub>OUT</sub>	V <sub>OUT</sub> Range		2.85	-	5.3	V	
V <sub>OUT</sub>	Fixed Output Voltage for Standard Versions  Other Output Voltages in the Range 3 V to 5.3 V are Available by Request.	NCP6868V315	VSEL LOW	-	3.15	-	V
			VSEL HIGH	-	3.35	-	V
		NCP6868V330	VSEL LOW	-	3.30	-	V
			VSEL HIGH	-	3.50	-	V
		NCP6868E315	VSEL LOW	-	3.15	-	V
			VSEL HIGH	-	3.60	-	V
		NCP6868P	VSEL LOW	-	P*	-	V
			VSEL HIGH	-	P*	-	V
I <sub>OUT</sub>	Continuous Output Current	For V <sub>OUT</sub> ≤ 3.5 V and P <sub>VIN</sub> ≥ 2.5 V	0	-	2.5	A	
I <sub>LoadStartMax</sub>	Maximum Load Current during Start-up		500			mA	
L	Inductor for DCDC Converter (Note 7)		-	0.47	-	μH	
C <sub>o</sub>	Output Capacitor for DCDC Converter (Note 7)		15	20	56	μF	
C <sub>in</sub>	Input Capacitor for DCDC Converter (Note 7)		3.3	4.7	-	μF	

Functional operation above the stresses listed in the Recommended Operating Ranges is not implied. Extended exposure to stresses beyond the Recommended Operating Ranges limits may affect device reliability.

\* P = Programmable.

- Operation above 5.5 V input voltage for extended period may affect device reliability.
- Including de-ratings (refer to application information section of this document for further details)

# NCP6868

## ELECTRICAL CHARACTERISTICS

Min & Max Limits apply for  $T_J$  up to +125°C unless otherwise specified.  $P_{VIN} = 2.35$  V to  $V_{OUT}$  (Unless otherwise noted). Typical values are referenced to  $P_{VIN} = 3.0$  V,  $T_A = +25^\circ\text{C}$  and default configuration (Figure 1) (Note 8)

Symbol	Parameter	Conditions	Min	Typ	Max	Unit	
<b>SUPPLY CURRENT: PIN <math>P_{VIN}</math></b>							
$I_{QBP}$	Operating Quiescent Current, Bypass Mode (Auto)	$V_{OUT} = 3.5$ V, $P_{VIN} = 3.7$ V	–	30	50	$\mu\text{A}$	
$I_{QBoost}$	Operating Quiescent Current, Boost Mode	$V_{OUT} = 3.5$ V, $P_{VIN} = 3.2$ V	–	55	70	$\mu\text{A}$	
$I_{SD}$	Shutdown Current	EN = Low, $P_{VIN} = 3.0$ V	–	1	5	$\mu\text{A}$	
$I_{QBPF\text{orced}}$	Forced Bypass Mode	$V_{OUT} = 3.5$ V, $P_{VIN} = 3.5$ V	Low IQ	–	3	8	$\mu\text{A}$
		$V_{OUT} = 3.5$ V, $P_{VIN} = 3.5$ V	OCP ON	–	25	40	$\mu\text{A}$

## DCDC CONVERTER

$P_{VIN}$	Input Voltage Range		2.35	–	5.5	V
$V_{OUT\_ACC}$	Output Voltage Accuracy	Referred to GND, DC, $V_{OUT} - P_{VIN} > 100$ mV	–2	–	4	%
$I_{OUTMAX}$	Boost Mode	For $V_{OUT} \leq 3.5$ V and $P_{VIN} \geq 2.5$ V	–	–	2.5	A
$P_{VINmin2.5A}$	Minimum $P_{VIN}$ for 2.5 A load	$V_{OUT} = 3.5$ V, $T_J < 120^\circ\text{C}$	–	2.5	–	V
		$V_{OUT} = 3.15$ V, $T_J < 120^\circ\text{C}$	–	2.35	–	V
$P_{VINmin2A}$	Minimum $P_{VIN}$ for 2A load	$V_{OUT} = 5.0$ V, $T_J < 120^\circ\text{C}$	–	3.0	–	V
		$V_{OUT} = 4.5$ V, $T_J < 120^\circ\text{C}$	–	2.8	–	V
$I_{LKout-in}$	$V_{OUT}$ to $P_{VIN}$ Reverse Leakage Current	$V_{OUT} = 5$ V, EN = Low	–	0.2	1	$\mu\text{A}$
$I_{LKout}$	$V_{OUT}$ Leakage Current	$V_{OUT} = 0$ V, EN = Low, $P_{VIN} = 4.2$ V	–	0.1	1	$\mu\text{A}$
$F_{SW}$	Switching Frequency	$P_{VIN} = 3.0$ V, $V_{OUT} = 3.35$ V, $I_{OUT} = 1$ A	2	2.5	3	MHz
$R_{ONPMOS}$	P-Channel MOSFET On Resistance (Synchronous Rectifier)	From SW to $V_{OUT}$ , $V_{OUT} = 3.5$ V, $P_{VIN} = 3.5$ V	–	30	60	$\text{m}\Omega$
$R_{ONNMOS}$	N-Channel MOSFET On Resistance (Boost Switch)	From SW to PGND, $V_{OUT} = 3.5$ V, $P_{VIN} = 3.5$ V	–	25	50	$\text{m}\Omega$
$R_{ONBP}$	Bypass P-MOSFET On Resistance	From $P_{VIN}$ to $V_{OUT}$ , $V_{OUT} = 3.5$ V, $P_{VIN} = 3.5$ V	–	35	60	$\text{m}\Omega$
$LOAD_{TR}$	Load Transient Response	$P_{VIN} = 3.0$ V, $V_{OUT} = 3.5$ V, $I_{OUT} = 500$ to $1500$ mA, $T_R = T_F = 0.1$ $\mu\text{s}$	–	$\pm 4$	–	%
$I_{PKlim}$	Boost Peak Current Limit	$P_{VIN} = 2.6$ V	–	5.0	9.0	A
$I_{SS\_PKlim}$	Boost Peak Current Limit at Soft-Start	$P_{VIN} = 2.6$ V	–	2.0	–	A
$I_{SSPK}$	Soft-Start Input Peak Current Limit		–	1600	–	mA
$T_{SS}$	Soft-Start EN High to Regulation	$50$ $\Omega$ Load, $C_{OUT} = 2 \times 10$ $\mu\text{F}$	–	400	500	$\mu\text{s}$

Product parametric performance is indicated in the Electrical Characteristics for the listed test conditions, unless otherwise noted. Product performance may not be indicated by the Electrical Characteristics if operated under different conditions.

8. Guaranteed by characterization and design.

# NCP6868

## ELECTRICAL CHARACTERISTICS

Min & Max Limits apply for  $T_J$  up to +125°C unless otherwise specified.  $P_{VIN} = 2.35\text{ V}$  to  $V_{OUT}$  (Unless otherwise noted). Typical values are referenced to  $P_{VIN} = 3.0\text{ V}$ ,  $T_A = +25^\circ\text{C}$  and default configuration (Figure 1)

Symbol	Parameter	Conditions	Min	Typ	Max	Unit
--------	-----------	------------	-----	-----	-----	------

### CONTROL PINS: EN, BP, VSEL

$V_{IH}$	Positive Going Input High Voltage Threshold		1.2	–	–	V
$V_{IL}$	Negative Going Input Low Voltage Threshold		–	–	0.4	V
$R_{PDown}$	Pull Down Internal Resistor at Control Pins (EN & VSEL)		–	40	–	mΩ
$R_{PUp}$	Pull Up Internal Resistor at /B/P Pin		–	10	–	mΩ

### I<sup>2</sup>C PROTOCOL

$V_{I^2CINT}$	High Level at SCL/SDA Line		1.7	–	5.0	V
$V_{I^2CIL}$	SCL, SDA Low Input Voltage	SCL, SDA Line (Notes 9, 10)	–	–	0.5	V
$V_{I^2CIH}$	SCL, SDA High Input Voltage	SCL, SDA Line (Notes 9, 10)	$0.8 \times V_{I^2CINT}$	–	–	V
$V_{I^2COL}$	SDA Low Output Voltage	SDA Pull Up Current = 3 mA (Note 10)	–	–	0.4	V
$F_{SCL}$	I <sup>2</sup> C Clock Frequency	(Note 10)	–	–	3.4	MHz

### POWER GOOD PIN: PG

$V_{OLPG}$	Power Good Pin Low Voltage Level	$I_{PG} = 5\text{ mA}$	–	–	0.4	V
$ILK_{PG}$	Power Good Pin Leakage Current	$V_{PG} = 5\text{ V}$	–	–	1	μA

### PROTECTIONS FEATURES

$V_{UVLO\_Fall}$	Under Voltage Lockout Threshold	$P_{VIN}$ Falling	2.25	2.30	2.35	V
$V_{UVLO\_Rise}$	Under Voltage Lockout Threshold	$P_{VIN}$ Rising	2.5	2.6	2.65	V
$V_{UVLOHys}$	Under Voltage Lockout Hysteresis		–	300	–	mV
$V_{OVP}$	Output Over-Voltage Protection Threshold		–	5.7	6.0	V
$V_{OVPhys}$	Output Over-Voltage Protection Hysteresis	(Note 10)	–	250	–	mV
$T_{PGact}$	PG Pin Activation Temperature Threshold (T <sub>WARN</sub> )		–	120	–	°C
$T_{PGrel}$	PG Pin Release Temperature Threshold		–	100	–	°C
$T_{SD}$	Thermal Shut Down Protection		–	150	–	°C
$T_{SDH}$	Thermal Shut Down Hysteresis		–	20	–	°C
$t_{RST}$	Fault Restart Timer		–	20	–	ms

Product parametric performance is indicated in the Electrical Characteristics for the listed test conditions, unless otherwise noted. Product performance may not be indicated by the Electrical Characteristics if operated under different conditions.

9. Devices that use non-standard supply voltages which do not conform to the intent I<sup>2</sup>C bus system levels must relate their input levels to the VDD voltage to which the pull-up resistors RP are connected.

10. Guaranteed by characterization and design.

**TYPICAL OPERATING CHARACTERISTICS (SUPPLY CURRENTS)**

$V_{OUT} = 3.5\text{ V}$ ,  $L = 0.47\ \mu\text{H}$ ,  $C_{OUT} = 2 \times 22\ \mu\text{F}$ ,  $C_{IN} = 10\ \mu\text{F}$ ,  $T_A = 25^\circ\text{C}$  (unless otherwise noted)

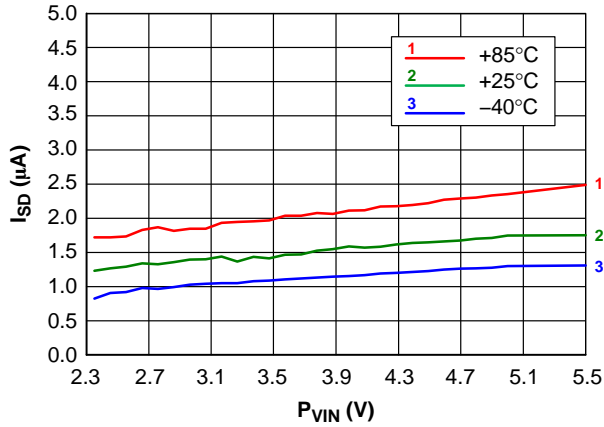

Figure 3. Shutdown Current vs Input Voltage

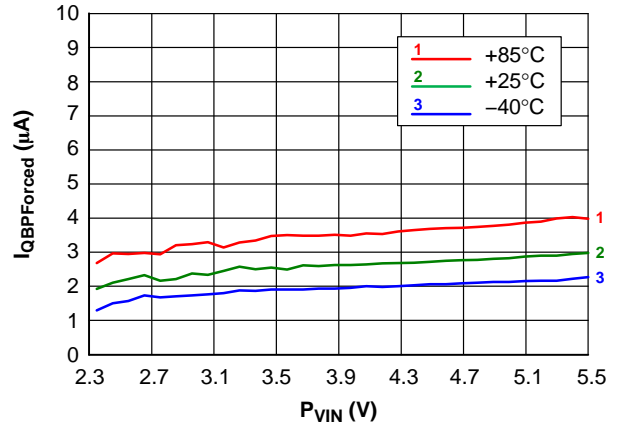

Figure 4. Quiescent Current in Forced Bypass Mode (OCP OFF) vs Input Voltage

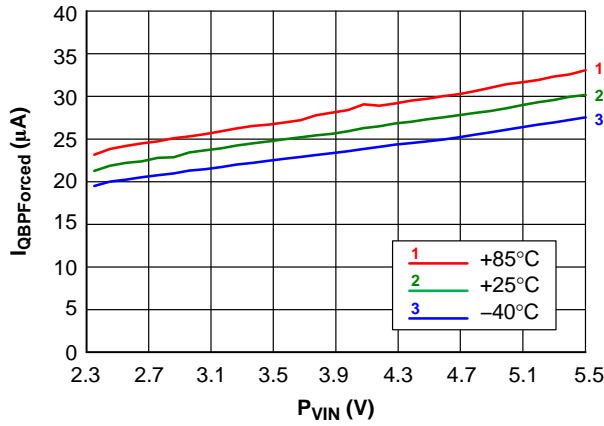

Figure 5. Quiescent Current in Forced Bypass Mode (OCP ON) vs Input Voltage

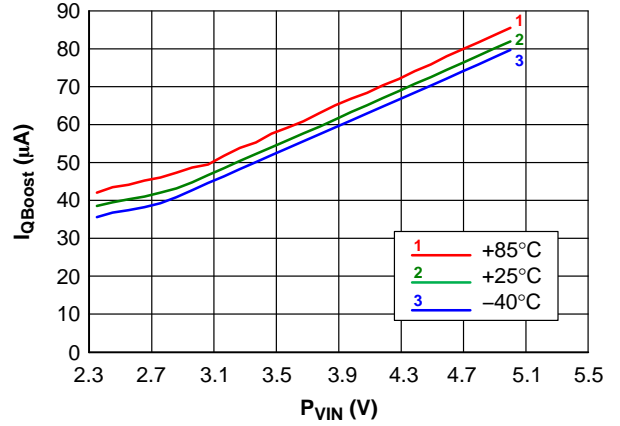

Figure 6. Boost Quiescent Current vs Input Voltage

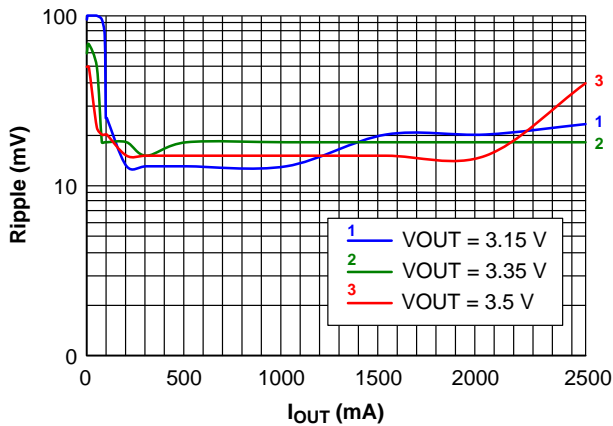

Figure 7.  $V_{OUT}$  Ripple vs Output Current

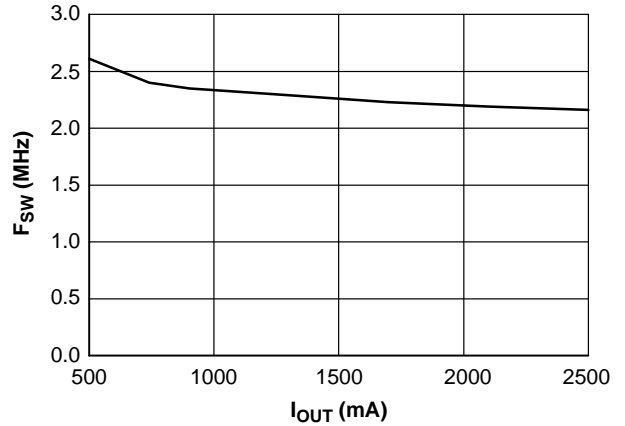

Figure 8. Frequency vs  $I_{OUT}$  for  $V_{OUT} = 3.35\text{ V}$

TYPICAL OPERATING CHARACTERISTICS (EFFICIENCY)

$L = 0.47 \mu\text{H}$  (TFM type),  $C_{\text{OUT}} = 3 \times 22 \mu\text{F}$ ,  $C_{\text{IN}} = 10 \mu\text{F}$ ,  $T_A = 25^\circ\text{C}$  (unless otherwise noted)

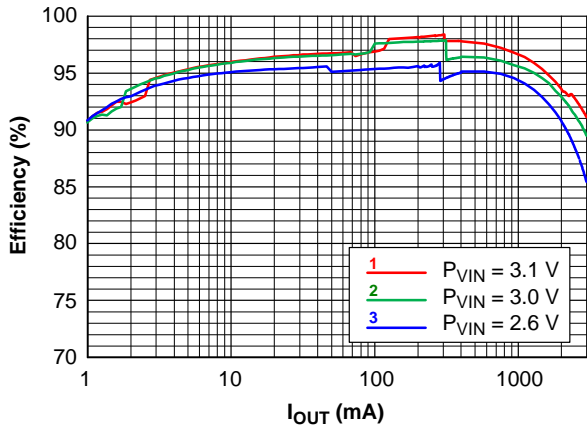

Figure 9. Efficiency vs Output Current,  $P_{\text{VIN}}$  with  $V_{\text{OUT}} = 3.15 \text{ V}$

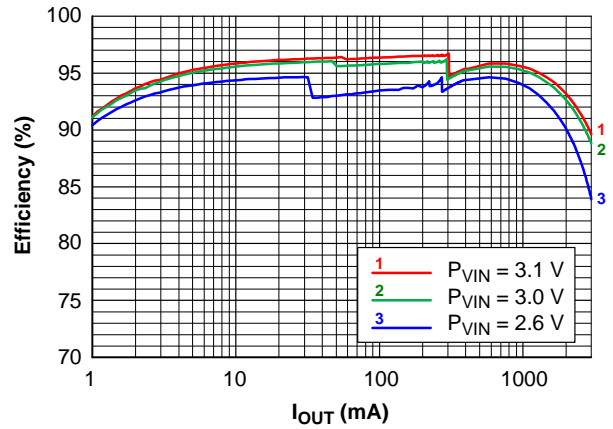

Figure 10. Efficiency vs Output Current,  $P_{\text{VIN}}$  with  $V_{\text{OUT}} = 3.5 \text{ V}$

$L = 0.47 \mu\text{H}$  (SPM type),  $C_{\text{OUT}} = 3 \times 22 \mu\text{F}$ ,  $C_{\text{IN}} = 10 \mu\text{F}$ ,  $T_A = 25^\circ\text{C}$  (unless otherwise noted)

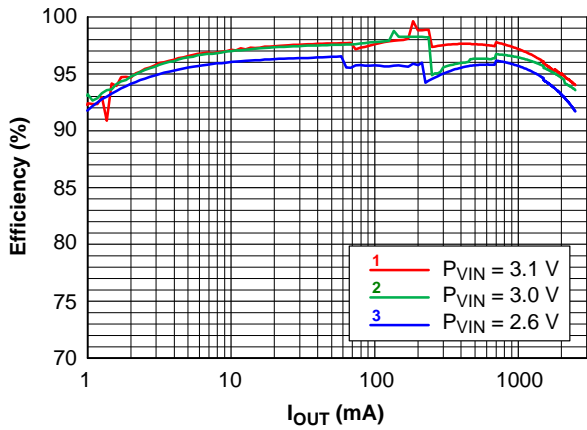

Figure 11. Efficiency vs Output Current,  $P_{\text{VIN}}$  with  $V_{\text{OUT}} = 3.15 \text{ V}$

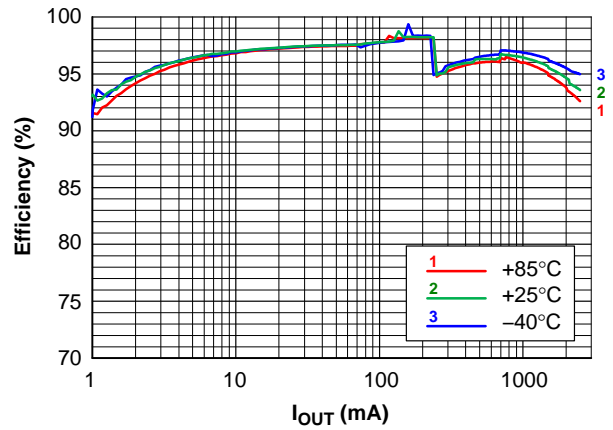

Figure 12. Efficiency vs Output Current and Temperature  $P_{\text{VIN}} = 3.0 \text{ V}$  and  $V_{\text{OUT}} = 3.15 \text{ V}$

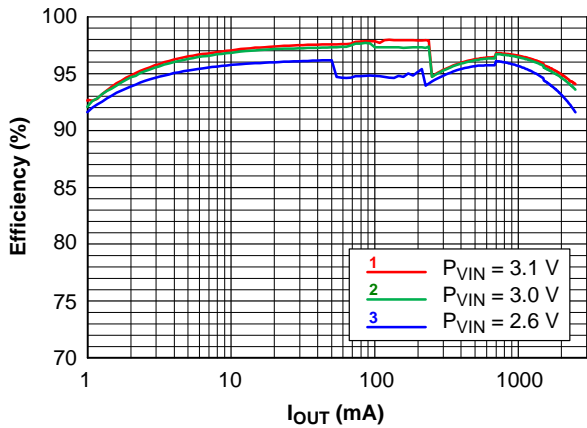

Figure 13. Efficiency vs Output Current,  $P_{\text{VIN}}$  with  $V_{\text{OUT}} = 3.3 \text{ V}$

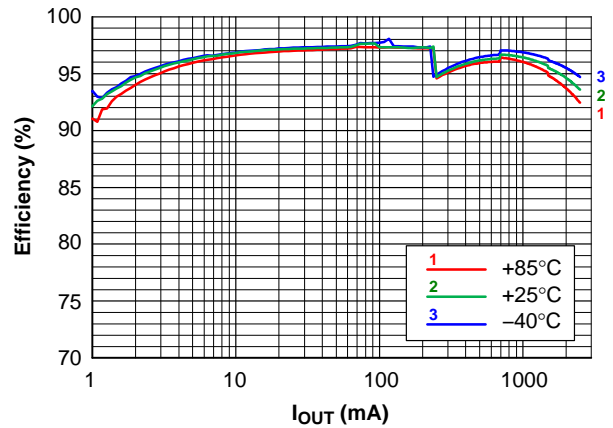

Figure 14. Efficiency vs Output Current and Temperature  $P_{\text{VIN}} = 3.0 \text{ V}$  and  $V_{\text{OUT}} = 3.3 \text{ V}$



TYPICAL OPERATING CHARACTERISTICS (EFFICIENCY)

$L = 0.47 \mu\text{H}$  (SPM type),  $C_{\text{OUT}} = 3 \times 22 \mu\text{F}$ ,  $C_{\text{IN}} = 10 \mu\text{F}$ ,  $T_A = 25^\circ\text{C}$  (unless otherwise noted)

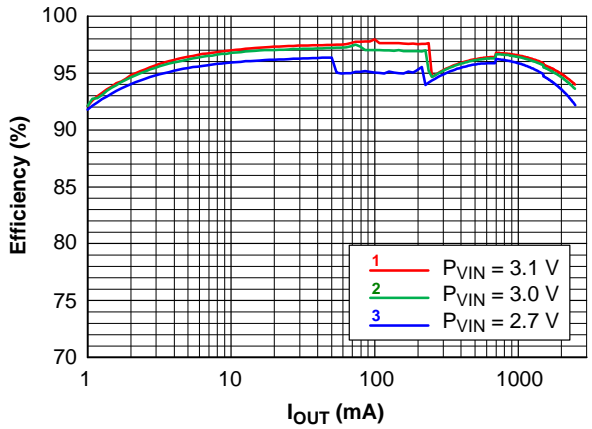

Figure 15. Efficiency vs Output Current,  $P_{\text{VIN}}$  with  $V_{\text{OUT}} = 3.35 \text{ V}$

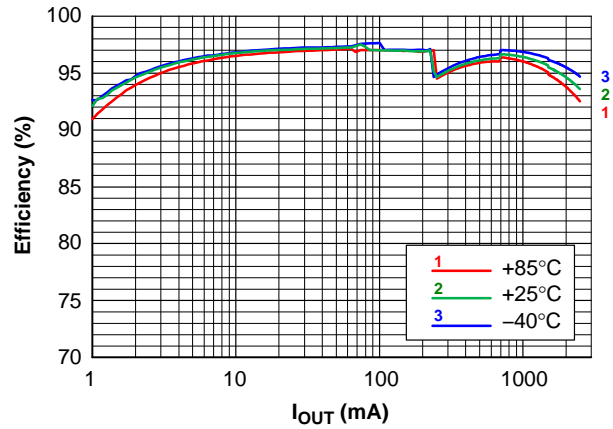

Figure 16. Efficiency vs Output Current and Temperature  $P_{\text{VIN}} = 3.0 \text{ V}$  and  $V_{\text{OUT}} = 3.35 \text{ V}$

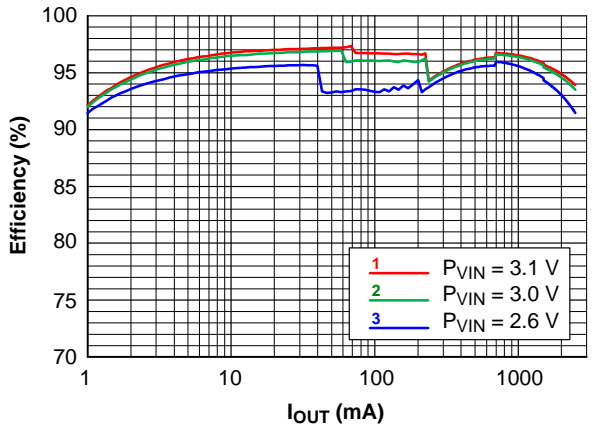

Figure 17. Efficiency vs Output Current,  $P_{\text{VIN}}$  with  $V_{\text{OUT}} = 3.5 \text{ V}$

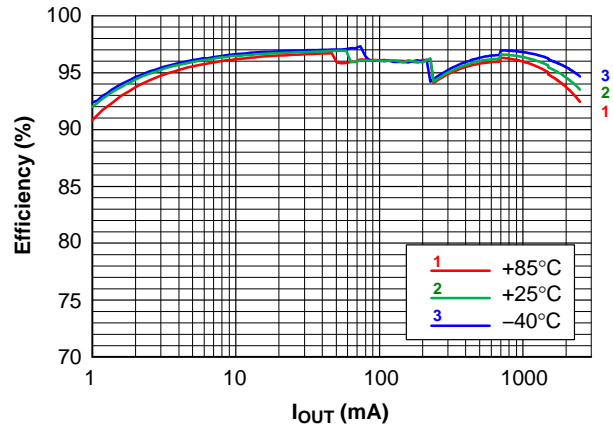

Figure 18. Efficiency vs Output Current and Temperature  $P_{\text{VIN}} = 3.0 \text{ V}$  and  $V_{\text{OUT}} = 3.5 \text{ V}$

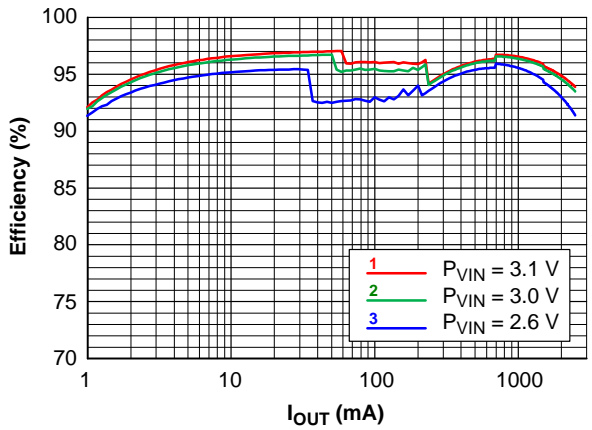

Figure 19. Efficiency vs Output Current,  $P_{\text{VIN}}$  with  $V_{\text{OUT}} = 3.6 \text{ V}$

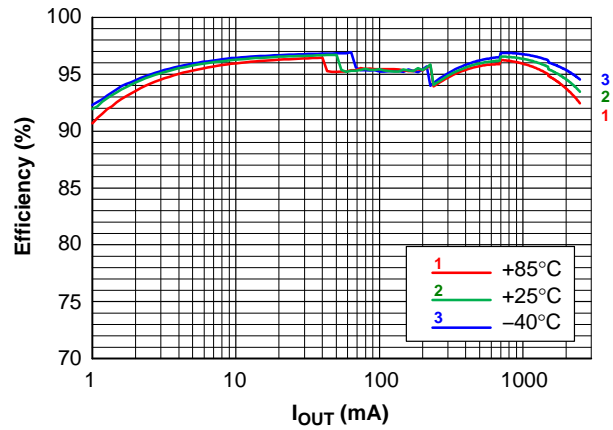

Figure 20. Efficiency vs Output Current and Temperature  $P_{\text{VIN}} = 3.0 \text{ V}$  and  $V_{\text{OUT}} = 3.6 \text{ V}$

TYPICAL OPERATING CHARACTERISTICS (START UP AND SHUT DOWN)

$L = 0.47 \mu\text{H}$  (TFM type),  $C_{\text{OUT}} = 3 \times 22 \mu\text{F}$ ,  $C_{\text{IN}} = 10 \mu\text{F}$ ,  $T_A = 25^\circ\text{C}$  (unless otherwise noted)

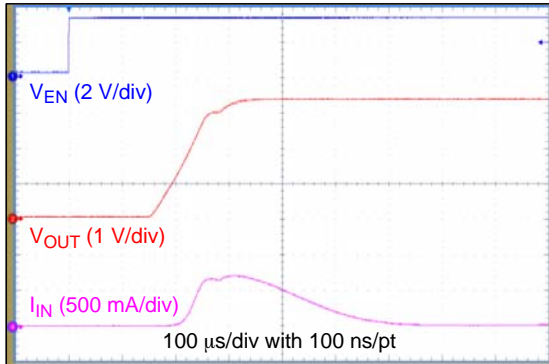

Figure 21. Power-Up Response, 50 Ω Load,  $V_{\text{OUT}} = 3.3 \text{ V}$

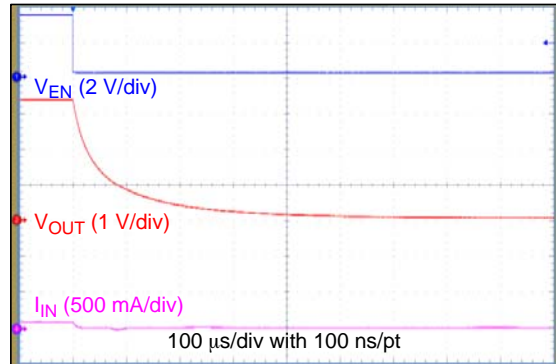

Figure 22. Power-Down Response, 50 Ω Load,  $V_{\text{OUT}} = 3.3 \text{ V}$

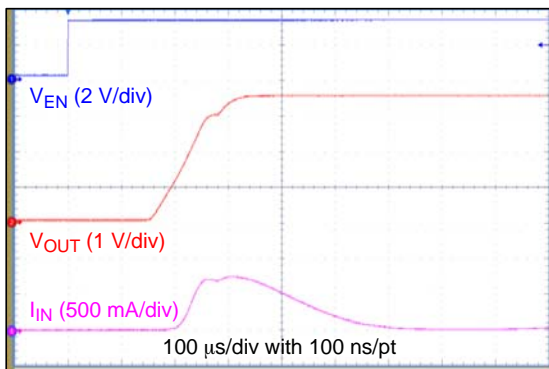

Figure 23. Power-Up Response, 50 Ω Load,  $V_{\text{OUT}} = 3.5 \text{ V}$

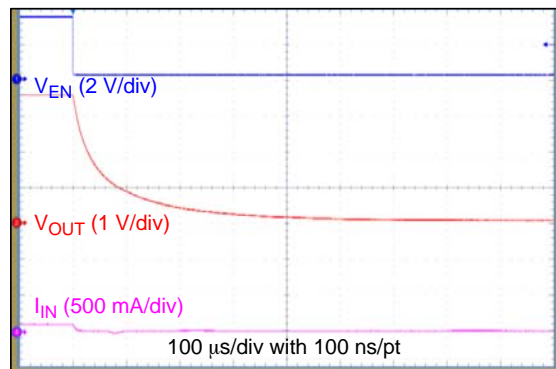

Figure 24. Power-Down Response, 50 Ω Load,  $V_{\text{OUT}} = 3.5 \text{ V}$

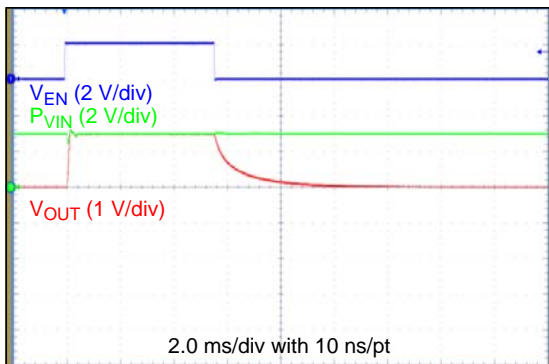

Figure 25. Power-Up/Down Response in Forced Bypass Mode,  $P_{\text{VIN}} = 3.0 \text{ V}$ , 25 Ω Load

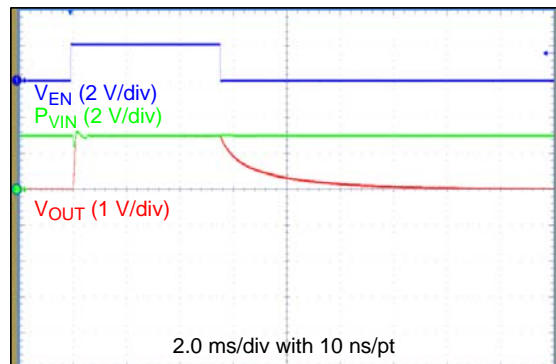
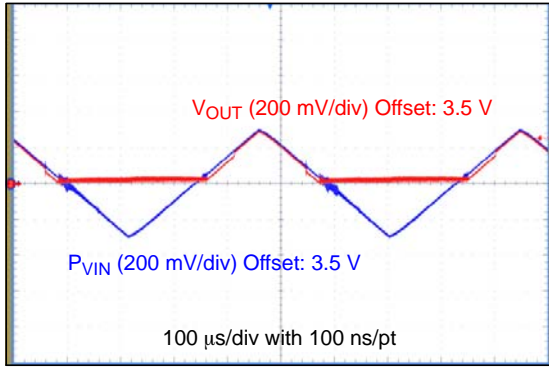

Figure 26. Power-Up/Down Response in Forced Bypass Mode,  $P_{\text{VIN}} = 3.0 \text{ V}$ , 50 Ω Load

# NCP6868

## TYPICAL OPERATING CHARACTERISTICS (DYNAMIC TRANSITION)

$L = 0.47 \mu\text{H}$  (TFM type),  $C_{\text{OUT}} = 3 \times 22 \mu\text{F}$ ,  $C_{\text{IN}} = 10 \mu\text{F}$ ,  $T_A = 25^\circ\text{C}$  (unless otherwise noted)



**Figure 27. Bypass Entry/Exit, Slow  $P_{\text{VIN}}$  Ramp**  
 1 ms Edge  $P_{\text{VIN}} = 3.2 \text{ V}$  to  $3.8 \text{ V}$ ,  
 $I_{\text{OUT}} = 500 \text{ mA}$  &  $V_{\text{OUT}} = 3.5 \text{ V}$

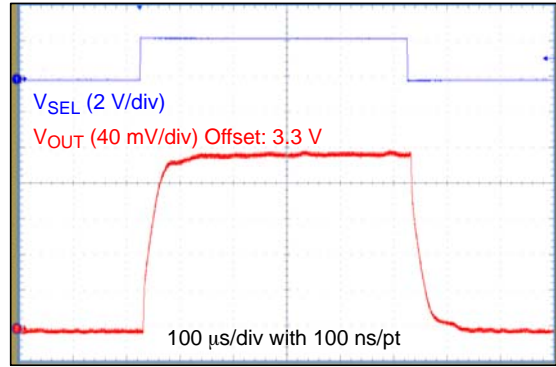

**Figure 28. VSEL Step**  
 $P_{\text{VIN}} = 3 \text{ V}$ ,  $I_{\text{OUT}} = 500 \text{ mA}$  &  $V_{\text{OUT}} = 3.5 \text{ V} \leftrightarrow 3.7 \text{ V}$

## TYPICAL OPERATING CHARACTERISTICS (LOAD TRANSIENT RESPONSES)

$L = 0.47 \mu\text{H}$  (TFM type),  $C_{\text{OUT}} = 3 \times 22 \mu\text{F}$ ,  $C_{\text{IN}} = 10 \mu\text{F}$ ,  $T_A = 25^\circ\text{C}$  (unless otherwise noted)

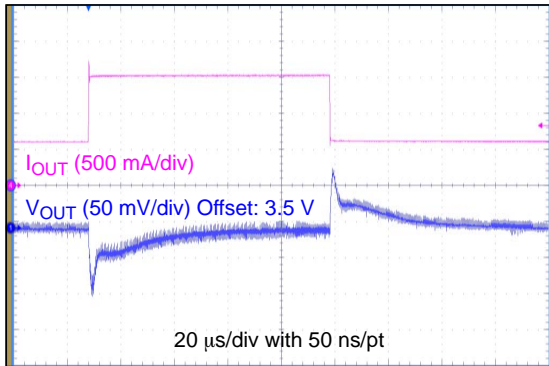

**Figure 29. Load Transient Response**  
 $I_{\text{OUT}} = 500$  to  $1500 \text{ mA}$ ,  $100 \text{ ns}$  Edge,  
 $P_{\text{VIN}} = 3 \text{ V}$  &  $V_{\text{OUT}} = 3.5 \text{ V}$

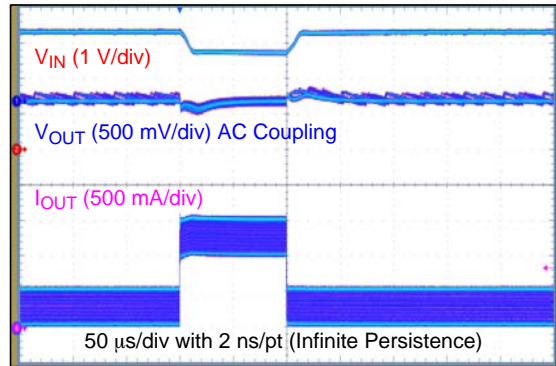

**Figure 30. Transient Response during Line Step**  
 ( $3.3 \text{ V}$  to  $2.7 \text{ V}$  in  $10 \mu\text{s}$ ),  $1 \text{ A}$   $I_{\text{OUT}}$  Step between  
 $0 \text{ A}$  and  $1500 \text{ mA}$ ,  $100 \text{ ns}$  Edge,  $V_{\text{OUT}} = 3.5 \text{ V}$

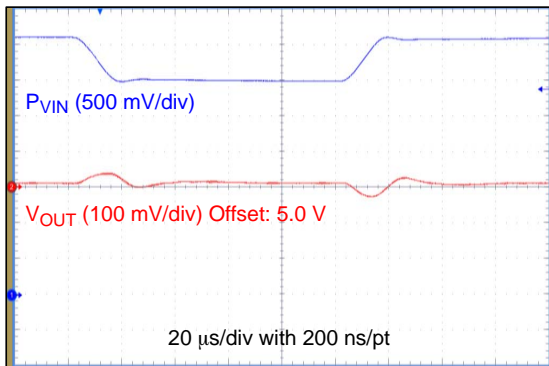

**Figure 31. Line Transient Response**  
 $P_{\text{VIN}} = 3 \text{ V}$  to  $3.6 \text{ V}$ ,  $10 \mu\text{s}$  Edge,  
 $I_{\text{OUT}} = 500 \text{ mA}$  &  $V_{\text{OUT}} = 5.0 \text{ V}$

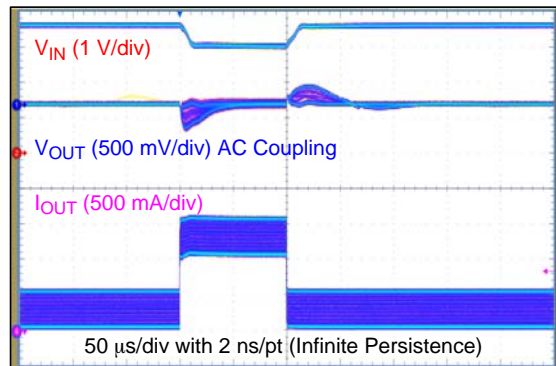

**Figure 32. Transient Response during Line Step**  
 ( $3.6 \text{ V}$  to  $3.0 \text{ V}$  in  $10 \mu\text{s}$ ),  $1 \text{ A}$   $I_{\text{OUT}}$  Step between  $0 \text{ A}$   
 and  $1500 \text{ mA}$ ,  $100 \text{ ns}$  Edge,  $V_{\text{OUT}} = 5.0 \text{ V}$

## OPERATING DESCRIPTION

**General Description**

The NCP6868 is a standalone synchronous step-up converter. It is designed primarily to boost new generation low-voltage Li-Ion batteries (silicon anode-like) embedded into cell and smart phones. The main function of the device is to maintain a minimum output voltage even when the battery voltage is below the system minimum. The device is capable of driving a continuous load up to 2.5 A when  $P_{VIN} = 2.5\text{ V}$  and  $V_{OUT} = 3.5\text{ V}$  and operates at a switching frequency of 2.5 MHz in Continuous Conduction Mode (CCM). The device features a Boost mode coupled with a Bypass mode. The Bypass mode is activated when  $P_{VIN}$  is above the boost regulator's  $V_{OUT}$  set-point (Low or High value set-point adjusted through VSEL pin).

In order to reduce the required  $V_{OUT}$  supply difference between heavy and light load the  $V_{OUT}$  voltage can be adjusted through VSEL for anticipating a heavy load transition. This allows optimizing power consumption during wide load transitions. The Bypass mode can be forced by setting the BP pin Low.

**Boost Mode**

The NCP6868 implements an architecture that allows the device to operate in Continuous Conduction Mode (CCM) and Discontinuous Conduction Mode (DCM) modes and smoothly transitions between CCM and DCM. The boost architecture provides very low transient response.

The NCP6868 operates in DCM mode in order to save power and improve efficiency at low loads by reducing the switching frequency. When the load increases and the current in the inductor becomes continuous, the controller automatically switches to CCM mode and switches back to DCM mode when the current in the inductor becomes discontinuous.

**Bypass Operating Mode**

The NCP6868 has been designed to manage conditions when  $P_{VIN}$  or  $V_{BAT}$  becomes close to the required output voltage of  $V_{OUT}$ . In this case the NCP6868 automatically enters the Bypass Operating Mode (or wire mode) from Boost mode and a low resistance on-state Bypass (BP) MOSFET is activated while the boost converter N-MOSFET is turned off. The output voltage is the same as input voltage minus a drop-out voltage resulting from the resistance of the BP MOSFET in parallel with the rectifier P-MOSFET plus the inductor. The consequence is a resulting resistance from  $P_{VIN}$  to  $V_{OUT}$  which is smaller than the resistance from the P-MOSFET + inductor when in Boost mode at 100% duty cycle. In this specific case the Bypass mode offers a better efficiency.

The device can be forced into Bypass mode by setting the BP pin Low.

**Shutdown State**

The NCP6868 enters the shutdown state when the EN pin is set Low (below 0.4 V) or when the  $P_{VIN}$  pin drops below its  $V_{UVLO\_Fall}$  threshold value. In this state the current consumption of the product is the Shutdown Current.

**Device Power-Up**

Applying a voltage above 1.2 V to the EN pin will enable the device for normal operation. A soft-start sequence is run when activating EN high. It is recommended when starting up the device to maintain a DC current load below 500 mA. During device enabling current flow is prevented from  $P_{VIN}$  to  $V_{OUT}$  and conversely from  $V_{OUT}$  to  $P_{VIN}$ .

Device power up and shutdown modes are detailed in Figure 33.

In I<sup>2</sup>C mode the device is configured and programmed through the I<sup>2</sup>C bus once it has been powered up (after Power On Reset) and prior to setting the EN pin High.

**VSEL Pin**

The VSEL pin controls the device output voltage level in regards to the anticipated load or line transitions which can occur, making the output voltage transitions smoother. The  $V_{OUT}$  voltage level is increased to the high value target by toggling the VSEL pin from Low to High. The output voltage change is transitioned to the target value in 20  $\mu\text{s}$ .

**Inductor Peak Current Limitations**

During normal operation, peak current limitation will monitor and limit the current through the inductor. This current limitation is particularly useful when size and/or height constrain inductor power.

**Under-Voltage Lockout (UVLO)**

The NCP6868 core does not operate for voltages below the Under Voltage Lock Out (UVLO) level. Below the  $V_{UVLO\_Fall}$  threshold (typical 2.3 V), all internal circuitries (both analog and digital) are held in reset. The NCP6868 is not guaranteed to operate down to the  $V_{UVLO\_Fall}$  level when the battery voltage is dropping off. To avoid erratic ON/OFF behavior, a hysteresis is implemented. Restart is guaranteed at  $V_{UVLO\_Rise}$  when  $V_{BAT}$  voltage is recovering or rising.

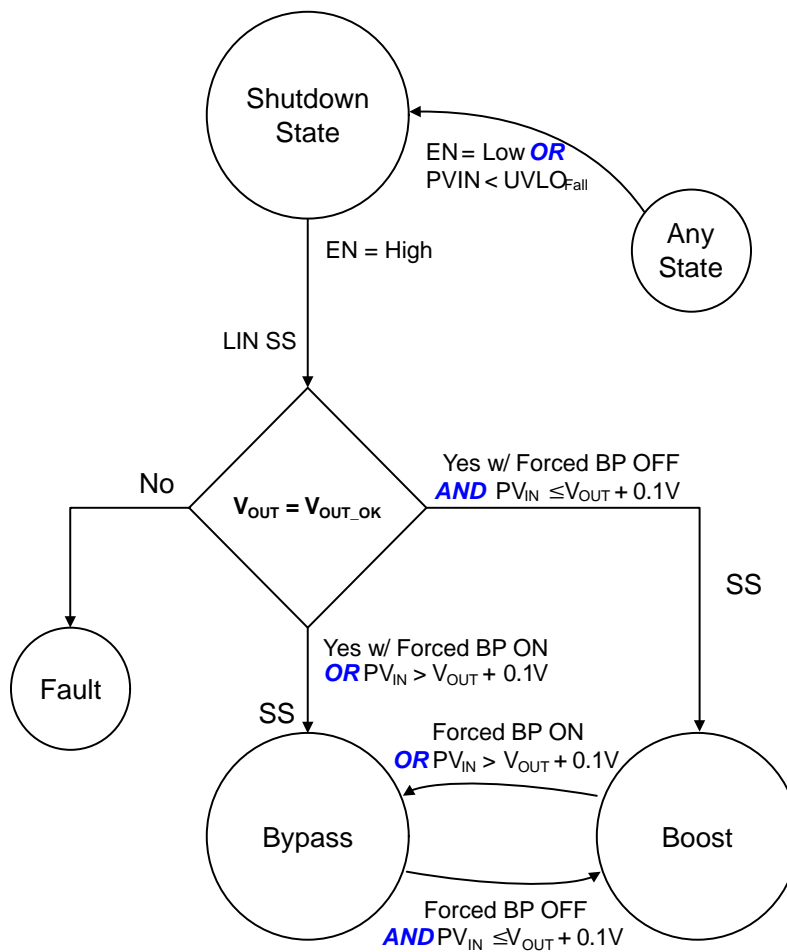

Figure 33. Start-up/Shutdown Diagram

**Power Good (PG) Pin and Thermal Management Features**

To indicate the output voltage level is established, a power good signal is available. In shutdown mode (EN = Low) PG is high.

The power good signal is low when the DC-to-DC converter is off when EN is High (during device starting up or precharge). Once the output voltage reaches 95% of the expected output level, the power good logic signal becomes high and the open drain output becomes high impedance. During operation when the output drops below 90% of the programmed level the power good logic signal goes low (and the open drain signal transitions to a low impedance state) which indicates a power failure. When the voltage rises again to above 95% the power good signal goes high again.

The Power Good pin can also be used as an interrupt pin operating as an over-temperature (TPGact/TPGrel), over-load or over-voltage warning function in order to prevent a potential device shutdown resulting respectively from the thermal, overload/short-circuit, or over-voltage protection.

The Power Good signal during normal operation can be disabled by clearing the PGDCDC bit in the Configuration Register CONFIG2 bit D3.

Table 5. POWER-GOOD DISABLE-LOW SOURCES

Interrupt Name	Power Good Off Events
POK	Power Good: DC-DC Out of Regulation or Off
TWARN	Thermal Warning (See TPGact & TPGrel)
UVLO	Under Voltage Lock Out
OC	Over-Current (ILIMBP & ILIMBST)
OV	Over-Voltage

**Over Current Protection, Bypass Mode**

The PG pin is pulled Low when the PMOS current limit has triggered for more than 64 μs. When this happens, the device will shut down in 0 s, 64 μs, 128 μs, or 256 μs depending on the programmed value of (BPSCTIMING[1,0]). The default shutdown delay is 0 s.

## NCP6868

After the device shuts down, the device will attempt to restart after 20 ms. Restarting will be tried 3 times before

definitely shutting down in order to eliminate erratic events due to negative spikes on  $V_{OUT}$ .

**Over Current Protection, Boost Mode**

In boost mode the current protection is enabled by two separate mechanisms. When the  $I_{PEAK}$  limit is triggered, boost mode will keep regulating for 2 ms and then will shut down immediately. During this period of time if the short circuit becomes active and drops the output voltage down to  $V_{IN}/2$  then the converter will shut down immediately. Therefore the device is protected in two ways based on an  $I_{PEAK}$  detection timing period of 2 ms and voltage drop detection. During this process of short circuit protection the PG pin toggles High to Low when  $V_{OUT}$  drops below 90% of  $V_{OUT}$  target.

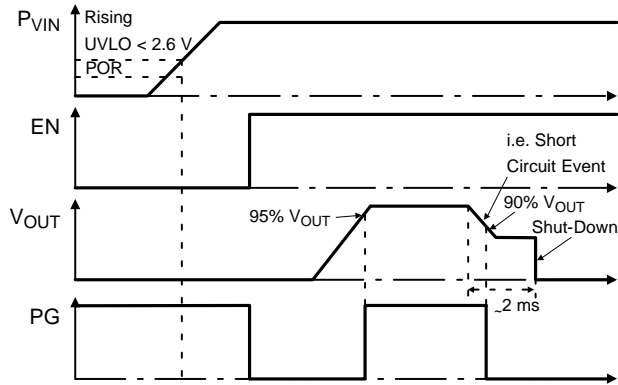

**Figure 34. Power Good (PG) Behavior Example**

**Over-Voltage Protection**

PG is pulled Low when the  $V_{OUT}$  voltage limit of 5.7 V has triggered for more than 64  $\mu$ s and the device will shut down. Afterwards the device will attempt to restart 20 ms after. This will be tried 3 times before definitely shutting down in order to eliminate erratic events due to negative spikes on  $V_{OUT}$ .

**Thermal Shutdown Feature (TSD)**

The thermal capability of an IC can be exceeded due to the boost converter output stage power level. A thermal protection circuitry has been implemented to prevent the device from damage. This protection circuitry is only activated when the core is in active mode (output voltage is turned on). During thermal shutdown, the output voltage is turned off and the device enters shutdown mode.

The thermal shutdown threshold is set at 150°C (typical) and a 20°C hysteresis has been implemented to avoid erratic on/off behavior. After a typical 150°C thermal shutdown, the NCP6868 will return to normal operation when the die temperature cools down to 130°C. This normal operation depends on the input conditions and configuration at the time the device recovers.

**Dynamic Voltage Scaling (DVS)**

The output voltage change is operated through the I<sup>2</sup>C or pin VSEL using a Dynamic Voltage Scaling (DVS) approach when the required voltage change is higher than 200 mV (Either by I<sup>2</sup>C or VSEL pin). The change between set points is managed in a smooth fashion without disturbing the operation of the device under power.

When programming a new output voltage that is greater than a 200 mV-increase, the output raises in steps of 200 mV every 32  $\mu$ s (typical) such that the dV/dt is controlled. The change rate of the voltage can be programmed as 32  $\mu$ s or 64  $\mu$ s with 32  $\mu$ s being the default value.

The DVS sequence is automatically initiated by changing output voltage settings. There are two ways to change these settings:

- Directly Change the Active Setting Register Value (PROGVOUTLOW [5,0]/PROGVOUTHIGH [5,0] Registers) via I<sup>2</sup>C Command
- Change the VSEL Internal Signal Level by Toggling VSEL Pin

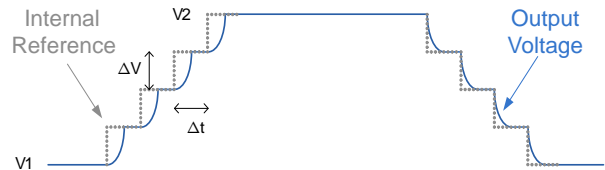

**Figure 35. DVS Diagram**

**Interrupt Control Process (INTSEN1, INTSEN2, INTACK & INTMSK Registers):**

The interrupt controller continuously monitors internal interrupt sources, generating an interrupt signal when a system status change is detected (dual edge monitoring).

Individual bits generating interrupts will be set to 1 in the INTACK register (I<sup>2</sup>C read only registers), indicating the interrupt source. INTACK register is automatically reset by an I<sup>2</sup>C read. The INTSEN1 and INTSEN2 registers (read only register) contains real-time indicators of interrupt sources.

All interrupt sources can be masked by writing in register INTMSK. Masked sources will never generate an interrupt request on PG pin (see Figure 41).

The PG pin is an open drain output. A non masked interrupt request will result in PG pin being driven low.

When the host reads the INTACK registers the PG pin is released to high impedance and the interrupt register INTACK is cleared.

Figure 36 illustrates the Interrupt process.

# NCP6868

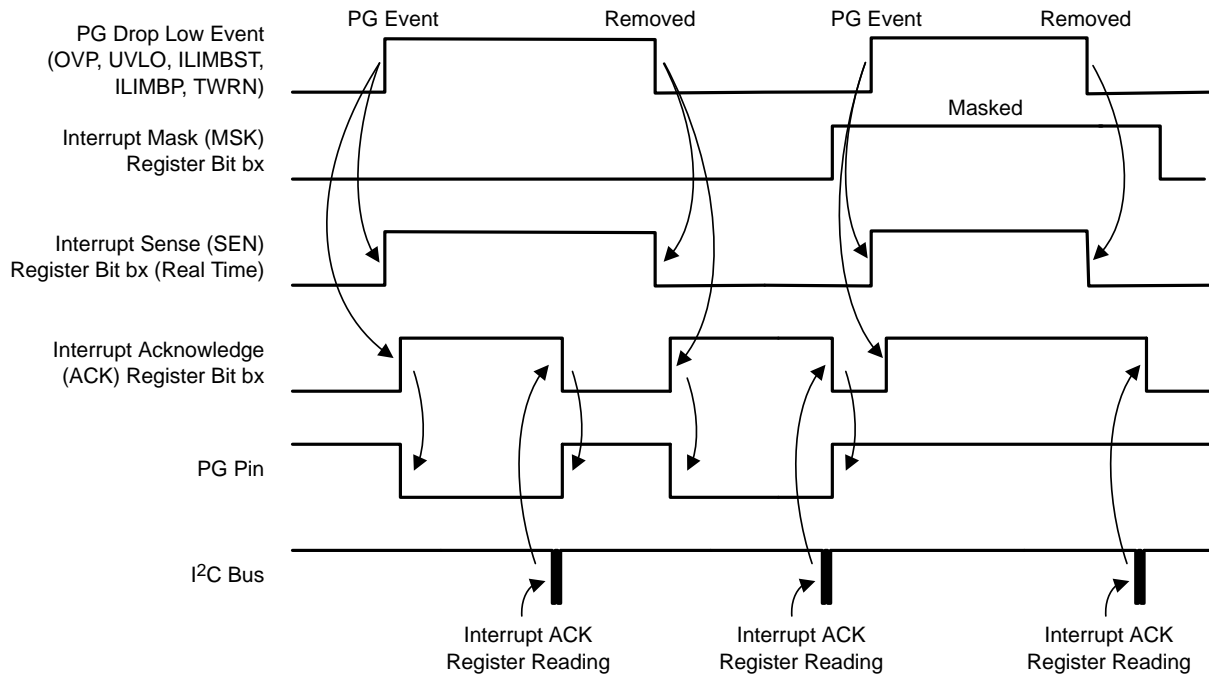

**Figure 36. Interrupt Operation Example**

## I<sup>2</sup>C Compatible Interface

The NCP6868 can support a subset of I<sup>2</sup>C protocol detailed below.

The NCP6868 communicates with the external processor by means of a serial link using a 400 kHz up to 3.4 MHz I<sup>2</sup>C two-wire interface protocol. The I<sup>2</sup>C interface provided is fully compatible with the Standard, Fast and High-Speed I<sup>2</sup>C modes. The NCP6868 is not intended to operate as a master controller. It is under the control of the main controller (master device), which controls the clock (pin SCL) and the read or write operations through SDA. The I<sup>2</sup>C bus is an addressable interface (7-bit addressing only) featuring two Read/Write addresses.

## I<sup>2</sup>C Communication Description

The first byte transmitted is the Chip address (with the LSB bit set to 1 for a read operation, or set to 0 for a Write operation). The following data will be:

- In case of a Write operation, the register address (@REG) pointing to the register we want to write is followed by the data we will write in that location. The writing process is auto-incremental, so the first data will be written in @REG, the contents of @REG are incremented and the next data byte is placed in the location pointed to by @REG + 1..., etc.
- In case of read operation, the NCP6868 will output the data from the last register that has been accessed by the last write operation. Like the writing process, the reading process is auto-incremental.

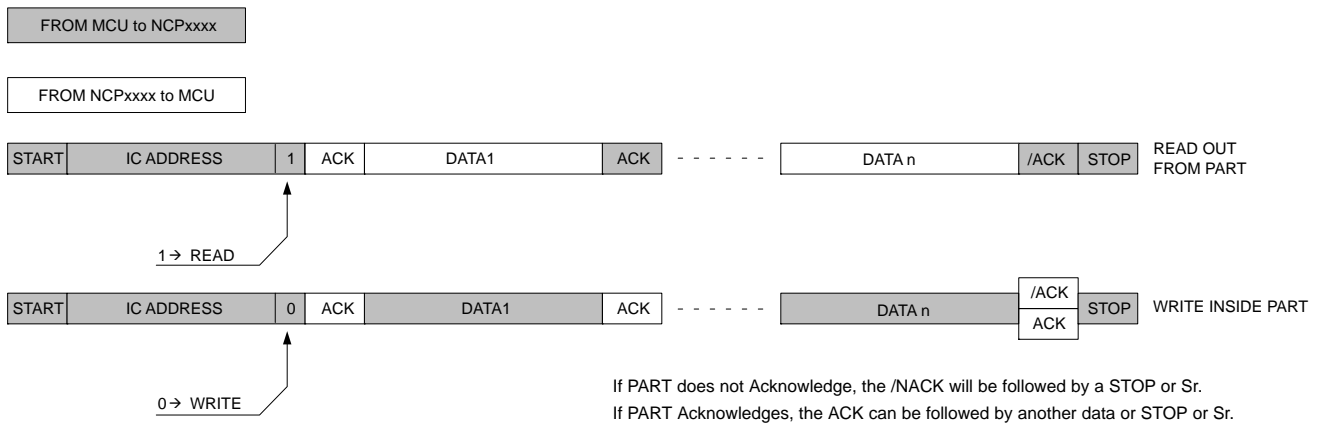

**Figure 37. General Protocol Description**



**Read Out from Part**

The Master will first make a “Pseudo Write” transaction with no data to set the internal address register. Then, a stop

then start or a Repeated Start will initiate the read transaction from the register address the initial write transaction has pointed to:

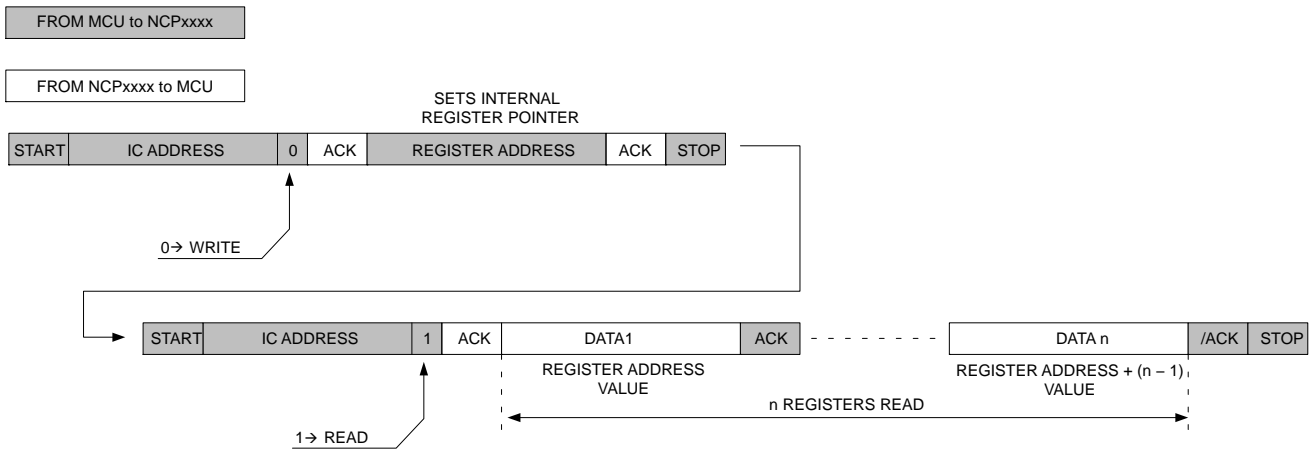
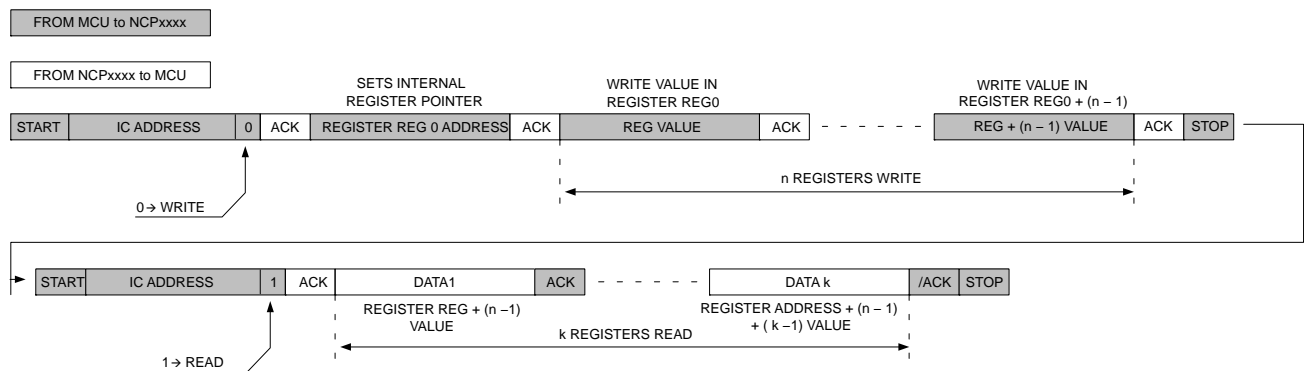

**Figure 38. Read Out from Part**

The first WRITE sequence will set the internal pointer to the register we want access to. Then the read transaction will start at the address the write transaction has initiated.

**Transaction with Real Write then Read**

*With Stop then Start*



**Figure 39. Write Followed by Read Transaction**

**Write in Part**

Write operation will be achieved by only one transaction. After chip address, the MCU first data will be the internal

register we want access to, then following data will be the data we want to write in Reg, Reg + 1, Reg + 2, ..., Reg + n.

*Write n Registers:*

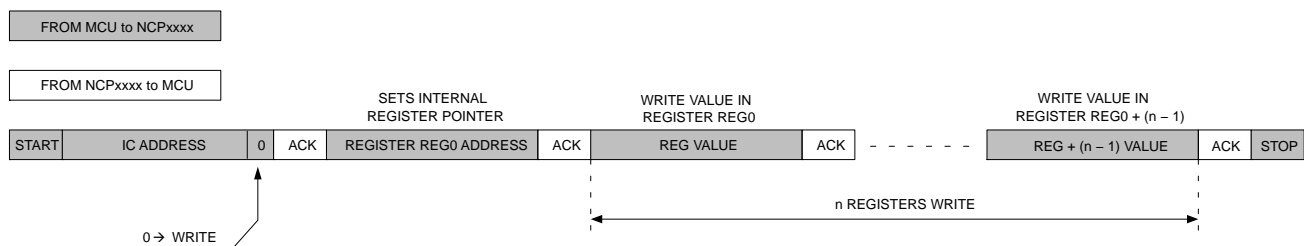

**Figure 40. Write in n Registers**

## NCP6868

### I<sup>2</sup>C Address

NCP6868 has four available I<sup>2</sup>C address selectable by factory settings (ADD0 to ADD3). Different address settings can be generated upon request to ON Semiconductor. The default address is set to ECh/EDh.

**Table 6. I<sup>2</sup>C ADDRESS**

I <sup>2</sup> C Address	Hex	A7	A6	A5	A4	A3	A2	A1	A0
ADD0	W 0xE8; R 0xE9	1	1	1	0	1	0	0	R/W
ADD1	W 0xEA; R 0xEB	1	1	1	0	1	0	1	R/W
<b>ADD2 (Default)</b>	<b>W 0xEC; R 0xED</b>	<b>1</b>	<b>1</b>	<b>1</b>	<b>0</b>	<b>1</b>	<b>1</b>	<b>0</b>	<b>R/W</b>
ADD3	W 0xEE; R 0xEF	1	1	1	0	1	1	1	R/W

### Register Map

Table 7 describes I<sup>2</sup>C registers.

*Registers can be:*

R: Read Only Register

RC: Read then Clear (Dual Edge)

R/W: Read and Write Register

Reserved: Address is Reserved and Register is Not Physically Designed

Spare: Address is Reserved and Register is Physically Designed

**Table 7. I<sup>2</sup>C REGISTERS MAP DESCRIPTION**

Address	Register Name	Type	Default	Function
00h	RID	R	00h	Revision Identification
01h	CONFIG	R/W	00h	Configuration Programming
02h	PROGVOUT_LOW	R/W	09h	VOUT Programming when VSEL = Low
03h	PROGVOUT_HIGH	R/W	0Dh	VOUT Programming when VSEL = High
04h	ILIM	R/W	03h	Current Limit Programming
05h	INTSEN1	R	00h	Sense Register (Real Time Status Register)
06h	INTSEN2	R	00h	Sense Register (Real Time Status Register)
07h	INTACK	RC	00h	Interrupt Register
08h	INTMSK	R/W	FFh	Mask Register to Enable or Disable Interrupt Sources (Trim)
09h	PID	R	68h	Product Identification
0Ah	FID	R	00h	Features Identification (Trim)
0Bh	CONFIG2	R/W	07h	Configuration Programming 2
0Ch to xxh	–	–	–	Reserved

# NCP6868

## Registers Description

**Table 8. REVISION ID REGISTER**

<b>Name: RID</b>				<b>Address: 00h</b>			
<b>Type: R</b>				<b>Default: 00000000b (00h)</b>			
<b>D7</b>	<b>D6</b>	<b>D5</b>	<b>D4</b>	<b>D3</b>	<b>D2</b>	<b>D1</b>	<b>D0</b>
RID_7	RID_6	RID_5	RID_4	RID_3	RID_2	RID_1	RID_0
<b>Bit</b>		<b>Bit Description</b>					
RID[7..0]		Revision Identification 00000000: Silicon Revision 1.0 00000001: Silicon Revision 1.1 00000010: Silicon Revision 1.2 00000100: Silicon Revision 1.3					

**Table 9. CONFIGURATION REGISTER**

<b>Name: CONFIG</b>				<b>Address: 01h</b>			
<b>Type: R/W</b>				<b>Default: 00000000b (00h)</b>			
<b>D7</b>	<b>D6</b>	<b>D5</b>	<b>D4</b>	<b>D3</b>	<b>D2</b>	<b>D1</b>	<b>D0</b>
FORCERST	ENABLE		Spare = 0			MODE[1,0]	
<b>Bit</b>		<b>Bit Description</b>					
MODE		Device Mode of Operation: 0x, 11: Normal Operation, Auto Mode 10: Forced CCM Mode					
ENABLE[6:5]		Device Enable Modes: 00: Device Operation Follows Hardware Control Signal (Refer to Table 2) 01: Device Operates in Auto Mode Regardless of the $\overline{BP}$ Pin (EN = 1) 10: Device is Forced in Bypass Mode Regardless of the BP Pin Value (EN = 1) 11: Device is in Shutdown Mode. During Shutdown, Current Flow is Prevented from $V_{IN}$ to $V_{OUT}$ and from $V_{OUT}$ to $V_{IN}$ . All Bias Circuits are Off					
FORCERST		Force Reset Bit 0: Normal Operation. Self Cleared to 0 1: Force Reset of Internal Registers to Default					

# NCP6868

**Table 10. DC TO DC OUTPUT VOLTAGE PROGRAMMING REGISTER**

<b>Name: PROGVOUTLOW</b>				<b>Address: 02h</b>			
<b>Type: R/W</b>				<b>Default: 00001001b (09h)</b>			
<b>D7</b>	<b>D6</b>	<b>D5</b>	<b>D4</b>	<b>D3</b>	<b>D2</b>	<b>D1</b>	<b>D0</b>
Spare = 0	Spare = 0	PROGVOUTLOW[5:0]					
<b>Bit</b>	<b>Bit Description</b>						
PROGVOUT LOW[5:0]	Sets the DC to DC Converter Output Voltage (see Table 11) <b>Default 00001001b =&gt; 3.3 V (VSEL = 0)</b>						

**Table 11. DC TO DC OUTPUT VOLTAGE PROGRAMMING**

PROGVOUTLOW[5:0]	V <sub>OUT</sub> (V) @ VSEL = 0
000000b	2.850
000001b	2.900
000010b	2.950
000011b	3.000
000100b	3.050
000101b	3.100
000110b	3.150
000111b	3.200
001000b	3.250
<b>001001b</b>	<b>3.300</b>
001010b	3.350
001011b	3.400
001100b	3.450
001101b	3.500
001110b	3.550
001111b	3.600
010000b	3.650
010001b	3.700
010010b	3.750
010011b	3.800
010100b	3.850
010101b	3.900
010110b	3.950
010111b	4.000

PROGVOUTLOW[5:0]	V <sub>OUT</sub> (V) @ VSEL = 0
011000b	4.050
011001b	4.100
011010b	4.150
011011b	4.200
011100b	4.250
011101b	4.300
011110b	4.350
011111b	4.400
100000b	4.450
100001b	4.500
100010b	4.550
100011b	4.600
100100b	4.650
100101b	4.700
100110b	4.750
100111b	4.800
101000b	4.850
101001b	4.900
101010b	4.950
101011b	5.000
101100b	5.050
101101b	5.100
101110b	5.150
101111b	5.200
110000b	5.250
110001b	5.300

# NCP6868

**Table 12. DC TO DC OUTPUT VOLTAGE PROGRAMMING REGISTER**

<b>Name: PROGVOUTHIGH</b>				<b>Address: 03h</b>			
<b>Type: R/W</b>				<b>Default: 00011001b (0Dh)</b>			
<b>D7</b>	<b>D6</b>	<b>D5</b>	<b>D4</b>	<b>D3</b>	<b>D2</b>	<b>D1</b>	<b>D0</b>
Spare = 0	Spare = 0	PROGVOUTHIGH[5:0]					
<b>Bit</b>	<b>Bit Description</b>						
PROGVOUTHIGH[5:0]	Sets the DC to DC Converter Output Voltage (see Table 13) <b>Default 00001101b =&gt; 3.5 V (VSEL = 1)</b>						

**Table 13. DC TO DC OUTPUT VOLTAGE PROGRAMMING**

PROGVOUTHIGH[5:0]	V <sub>OUT</sub> (V) @ VSEL = 1
000000b	2.850
000001b	2.900
000010b	2.950
000011b	3.000
000100b	3.050
000101b	3.100
000110b	3.150
000111b	3.200
001000b	3.250
001001b	3.300
001010b	3.350
001011b	3.400
001100b	3.450
<b>001101b</b>	<b>3.500</b>
001110b	3.550
001111b	3.600
010000b	3.650
010001b	3.700
010010b	3.750
010011b	3.800
010100b	3.850
010101b	3.900
010110b	3.950
010111b	4.000

PROGVOUTHIGH[5:0]	V <sub>OUT</sub> (V) @ VSEL = 1
011000b	4.050
011001b	4.100
011010b	4.150
011011b	4.200
011100b	4.250
011101b	4.300
011110b	4.350
011111b	4.400
100000b	4.450
100001b	4.500
100010b	4.550
100011b	4.600
100100b	4.650
100101b	4.700
100110b	4.750
100111b	4.800
101000b	4.850
101001b	4.900
101010b	4.950
101011b	5.000
101100b	5.050
101101b	5.100
101110b	5.150
101111b	5.200
110000b	5.250
110001b	5.300

# NCP6868

**Table 14. PEAK CURRENT LIMIT REGISTER**

<b>Name: ILIM</b>				<b>Address: 04h</b>			
<b>Type: R/W</b>				<b>Default: 00000011 (03h)</b>			
<b>D7</b>	<b>D6</b>	<b>D5</b>	<b>D4</b>	<b>D3</b>	<b>D2</b>	<b>D1</b>	<b>D0</b>
Spare = 0	SCPBP_DIS	ILIM_DIS	Spare = 0	ILIM [3:0]			
<b>Bit</b>		<b>Bit Description</b>					
ILIM		Inductor Peak Current Settings (see Table 15)					
ILIM_DIS		Enable/Disable Peak Inductor Current Limit 0: Current Limit Enabled 1: Current Limit Disabled					
SCPBP_DIS		Enable/Disable Bypass Short Circuit Protection 0: Protection Enabled 1: Protection Disabled					

**Table 15. DC TO DC PEAK CURRENT LIMIT PROGRAMMING**

ILIM[3:0]	Peak Current Setting
0000b	2 A
0001b	3 A
0010b	4 A

ILIM[3:0]	Peak Current Setting
0011b	5 A
0100b	6 A
0101b	7 A
0110b	8 A
0111b	9 A

**Table 16. INTERRUPT SENSE REGISTER 1**

<b>Name: INTSEN1</b>				<b>Address: 05h</b>			
<b>Type: R</b>				<b>Default: 00000000b (00h)</b>			
<b>D7</b>	<b>D6</b>	<b>D5</b>	<b>D4</b>	<b>D3</b>	<b>D2</b>	<b>D1</b>	<b>D0</b>
SEN_TSD	SEN_TWARN	SEN_DCDCMODE	SEN_OPMODE	SEN_ILIMBP	SEN_ILIMBST	Spare = 0	SEN_POK
<b>Bit</b>		<b>Bit Description</b>					
SEN_POK		Power Good Ok Sense <b>0: DCDC Output Voltage below Target</b> 1: DCDC Output Voltage within Nominal Range. This Bit is Set if the Converter is Forced in Bypass Mode					
SEN_ILIMBST		Current Limit Status Bit (DC-DC Boost Mode): <b>0: DCDC Output Current is below Limit</b> 1: DCDC Output Current is over Limit					
SEN_ILIMBP		Current Status Bit (Bypass Mode) <b>0: Bypass Output Current is below Limit</b> 1: Bypass Output Current is over Limit					
SEN_OPMODE		Device Mode of Operation Status Bit: <b>0: Device Operates in Bypass Mode</b> 1: Device Operates in Boost Mode					
SEN_DCDCMODE		DC-DC Mode of Operation Status Bit: <b>0: Device Operates in DCM Mode</b> 1: Device Operates in CCM Mode					
SEN_TWARN		Thermal Warning Sense <b>0: Junction Temperature below Thermal Warning Limit</b> 1: Junction Temperature over Thermal Warning Limit					
SEN_TSD		Thermal Shutdown Sense <b>0: Junction Temperature below Thermal Shutdown Limit</b> 1: Junction Temperature over Thermal Shutdown Limit					

# NCP6868

**Table 17. INTERRUPT SENSE REGISTER 2**

<b>Name: INTSEN2</b>				<b>Address: 06h</b>			
<b>Type: R</b>				<b>Default: 00000000b (00h)</b>			
<b>D7</b>	<b>D6</b>	<b>D5</b>	<b>D4</b>	<b>D3</b>	<b>D2</b>	<b>D1</b>	<b>D0</b>
Spare = 0			SEN_OV	SEN_UVLO	Spare = 0		
<b>Bit</b>		<b>Bit Description</b>					
SEN_UVLO		Under Voltage Sense <b>0: Input Voltage Higher than UVLO Threshold</b> 1: Input Voltage Lower than UVLO Threshold					
SEN_OV		Over Voltage Sense <b>0: Output Voltage Lower than OVP Threshold</b> 1: Output Voltage Higher than OVP Threshold					

**Table 18. INTERRUPT ACKNOWLEDGE REGISTER**

<b>Name: INTACK</b>				<b>Address: 07h</b>			
<b>Type: RC</b>				<b>Default: 00000000b (00h)</b>			
<b>Trigger: Dual Edge [D7...D0]</b>							
<b>D7</b>	<b>D6</b>	<b>D5</b>	<b>D4</b>	<b>D3</b>	<b>D2</b>	<b>D1</b>	<b>D0</b>
ACK_TSD	ACK_TWARN	ACK_ILIMBST	ACK_OV	ACK_UVLO	ACK_ILIMBP	Spare = 0	ACK_POK
<b>Bit</b>		<b>Bit Description</b>					
ACK_POK		Power Good Sense Acknowledgement <b>0: Cleared</b> 1: DCDC Power Good Event Detected					
ACK_ILIMBP		ByPass Over Current Sense <b>0: Cleared</b> 1: ByPass Over Current Limit Detected					
ACK_UVLO		Under Voltage Sense Acknowledgement <b>0: Cleared</b> 1: Under Voltage Event Detected					
ACK_OV		Over Voltage Sense Acknowledgement <b>0: Cleared</b> 1: Over Voltage Event Detected					
ACK_ILIMBST		DCDC Over Current Sense <b>0: Cleared</b> 1: DCDC Over Current Limit Detected					
ACK_TWARN		Thermal Warning Sense Acknowledgement <b>0: Cleared</b> 1: Thermal Warning Event Detected					
ACK_TSD		Thermal Shutdown Sense Acknowledgement <b>0: Cleared</b> 1: Thermal Shutdown Event Detected					

Table 19. INTERRUPT MASK REGISTER

<b>Name: INTMASK</b>				<b>Address: 08h</b>			
<b>Type: RW</b>				<b>Default: 1111111b (FFh)</b>			
<b>D7</b>	<b>D6</b>	<b>D5</b>	<b>D4</b>	<b>D3</b>	<b>D2</b>	<b>D1</b>	<b>D0</b>
MASK_TSD	MASK_TWARN	MASK_ILIMBST	MASK_OV	MASK_UVLO	MASK_ILIMBP	Spare = 1	MASK_POK
<b>Bit</b>		<b>Bit Description</b>					
MASK_POK		Power Good Interrupt Source Mask 0: Interrupt is Enabled <b>1: Interrupt is Masked</b>					
MASK_ILIMBP		DCDC over Current Interrupt Source Mask 0: Interrupt is Enabled <b>1: Interrupt is Masked</b>					
MASK_UVLO		Under Voltage Interrupt Source Mask 0: Interrupt is Enabled <b>1: Interrupt is Masked</b>					
MASK_OV		Over Voltage Interrupt Source Mask 0: Interrupt is Enabled <b>1: Interrupt is Masked</b>					
MASK_ILIMBST		DCDC over Current Interrupt Source Mask 0: Interrupt is Enabled <b>1: Interrupt is Masked</b>					
MASK_TWARN		Thermal Warning Interrupt Source Mask 0: Interrupt is Enabled <b>1: Interrupt is Masked</b>					
MASK_TSD		Thermal Shutdown Interrupt Source Mask 0: Interrupt is Enabled <b>1: Interrupt is Masked</b>					

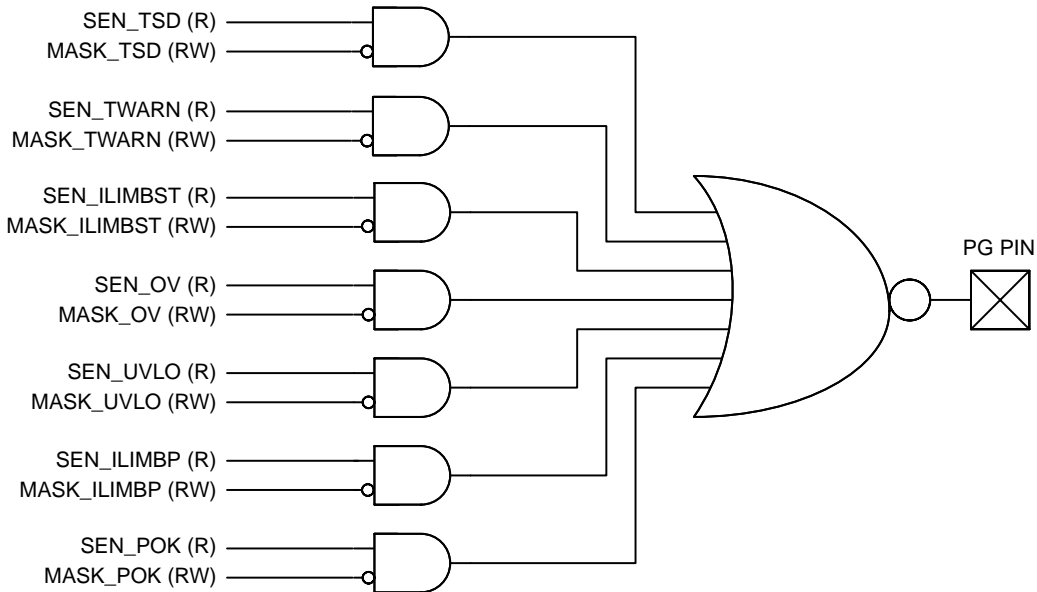

PG pin will go to low state if the corresponding sense goes to 1 AND if the corresponding mask is cleared.

Figure 41. Interruption Masking Logical Diagram



# NCP6868

**Table 20. PRODUCT ID REGISTER**

<b>Name: PID</b>				<b>Address: 09h</b>			
<b>Type: R</b>				<b>Default: 01101000b (68h)</b>			
D7	D6	D5	D4	D3	D2	D1	D0
PID[7:4]				PID[3:0]			
<b>Bit</b>		<b>Bit Description</b>					
PID[7..0]		Product Identification 01101000b = 68h w/ PID[7:4] = 6, PID[3:0] = 8					

**Table 21. FIRMWARE ID REGISTER**

<b>Name: FID</b>				<b>Address: 0Ah</b>			
<b>Type: R</b>				<b>Default: 00000000b (00h)</b>			
D7	D6	D5	D4	D3	D2	D1	D0
FID_7	FID_6	FID_5	FID_4	FID_3	FID_2	FID_1	FID_0
<b>Bit</b>		<b>Bit Description</b>					
FID[7..0]		Firmware Identification <b>00000000: Firmware Revision 1.0</b> 00000001: Firmware Revision 1.1 00000010: Firmware Revision 1.2 00000011: Firmware Revision 1.3 ...					

**Table 22. CONFIGURATION REGISTER 2**

<b>Name: CONFIG2</b>				<b>Address: 0Bh</b>			
<b>Type: R/W</b>				<b>Default: 00000111 (07h)</b>			
D7	D6	D5	D4	D3	D2	D1	D0
Spare = 0		BPSCTIMING[1,0]		DVSTIMING	PGDCDC	RSTSTATUS	REARM
<b>Bit</b>		<b>Bit Description</b>					
REARM		Rearming of Device after TSD 0: No Re-Arming after TSD <b>1: Re-Arming Active after TSD with No Reset of I<sup>2</sup>C Registers: New Power-Up Sequence is Initiated with Previously Programmed I<sup>2</sup>C Registers Values</b>					
RSTSTATUS		Reset Indicator Bit 0: Must be Written to 0 after Register Reset <b>1: Default (Loaded after Registers Reset)</b>					
PGDCDC		Power Good Enabling 0 = Disable <b>1 = Enable</b>					
DVSTIMING		DVS Timing Change <b>0 = 200 mV Step / 32 μs</b> 1 = 200 mV Step / 64 μs					
BPSCTIMING[1,0]		Short-Circuit Protection Activation Delay <b>00 = 0 s</b> 01 = 64 μs 10 = 128 μs 11 = 256 μs					

APPLICATION INFORMATION

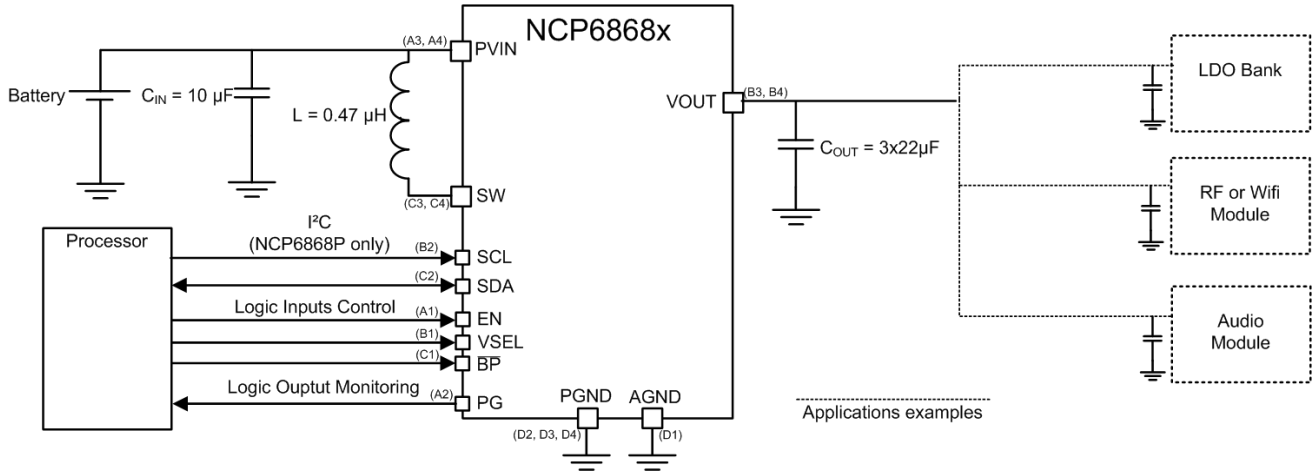

Figure 42. Application Block Diagram

**Inductor Selection**

The selected inductor must have high enough saturation current rating to be higher than the maximum peak current which can reach 4 A for the default configuration for a short period of time during overload situations. Table 23 shows

recommended inductor featuring 0.47 µH of nominal value. Peak-current limit inductor is used.

The inductor also needs to have high enough current rating based on temperature rise concern. Low DCR is good for efficiency improvement and temperature rise reduction.

Table 23. RECOMMENDED INDUCTORS

Supplier	Part #	Value (µH)	Size (L × l × T) (mm)	DC Rated Current (A)	DCR Max @ 25°C (mΩ)
Toko	DFE201610A-R47M-T00	0.47	20 × 16 × 1	4.0	53
Toko	DFE201610P-R47M-T00	0.47	20 × 16 × 1	4.1	41
Toko	DFE201612R-R47M-T00	0.47	20 × 16 × 1.2	4.4	40
Toko	DFE201612P-R47M-T00	0.47	20 × 16 × 1.2	4.9	33
CYNTEC	HMLQ20161T-R47MDR-11	0.47	2.0 × 1.6 × 1.0	4.4	26
CYNTEC	HMLQ20161B-R47MDR-11	0.47	2.0 × 1.6 × 1.2	5.1	20
CYNTEC	HMLQ25201T-R47MSR-11	0.47	2.5 × 2.0 × 1.0	4.3	19
TDK	TFM252010A-R47M	0.47	25 × 20 × 1.0	4.5	30
TDK	TFM252010GHM-R47MTAA	0.47	25 × 20 × 1.0	4.3	26

**Output Capacitor Selection**

The output capacitor selection is determined by the output voltage ripple and the load transient response requirement. For high transient load performance a high output capacitor value must be used. It is recommended to pay attention to the variation of the capacitor value when the bias voltage across this capacitor varies. Usually the capacitor value decreases with the bias voltage and X5R/X7R low ESR ceramic capacitors are recommended in order to guarantee the effective capacitor value under operating conditions.

rail, a ceramic capacitor is recommended due to low ESR and ESL.

The input capacitor needs also to be sufficient to protect the device from over voltage spike and a minimum of 4.7 µF capacitor is required. The input capacitor should be located as close as possible to the IC. PGND is connected to the ground terminal of the input cap which then connects to the ground plane. The PVIN is connected to the VBAT terminal of the input capacitor which then connects to the VBAT plane.

**Input Capacitor Selection**

One criteria for the input capacitor selection is the input voltage ripple requirement. To minimize the input voltage ripple and get better decoupling in the input power supply

**Layout and PCB Design Recommendations**

Good PCB layout helps high power dissipation from a small package with reduced temperature rise. Thermal layout guidelines are:

## NCP6868

- A four or more layers PCB board with solid ground planes is preferred for better heat dissipation.
- Adding extra vias around the IC is encouraged to connect the inner ground layers to reduce thermal impedance.
- Use large area copper especially in the top layer to help thermal conduction and radiation.
- Use two layers for the high current paths ( $P_{VIN}$ ,  $PGND$ ,  $SW$ ,  $V_{OUT}$ ) in order to split current in two different paths and limit PCB copper self heating.

(See demo board example Figure 43)

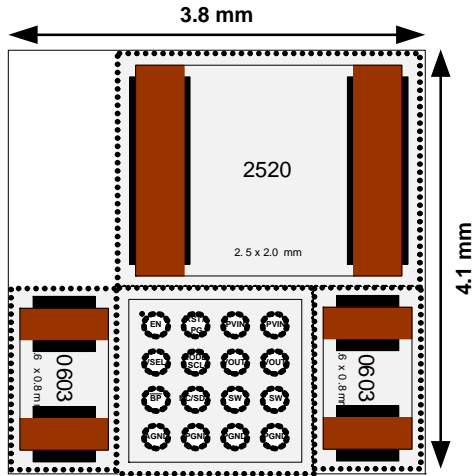

$$S < 16 \text{ mm}^2$$

Figure 43. Layout Minimum Recommended Occupied Space

The input capacitor is placed as close as possible to the IC.  $P_{VIN}$  is directly connected to the  $C_{IN}$  input capacitor, and then connected to the  $P_{VIN}$  plane. Local mini planes are used on the top layer (green) and layer just below top layer with laser vias.

$PGND$  is directly connected to the  $C_{IN}$  input capacitor, and then connected to the  $GND$  plane. Local mini planes are used on the top layer (green) and layer just below top layer with laser vias.

$SW$  is connected to the  $LX$  inductor with local mini planes used on the top layer (green) and layer just below top layer with laser vias.

$V_{OUT}$  is directly connected to the  $C_{OUT}$  output capacitor and then connected to the  $PGND$  plane.

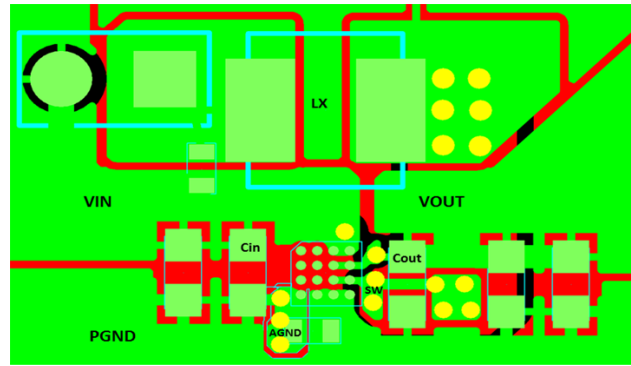

Figure 44. Example of PCB Implementation

Table 24. ORDERING INFORMATION

Device*	Package	Shipping†
NCP6868PFCCT1G	WLCSP16 (Pb-Free)	3000 / Tape & Reel
NCP6868V315FCCT1G	WLCSP16 (Pb-Free)	3000 / Tape & Reel
NCP6868V330FCCT1G	WLCSP16 (Pb-Free)	3000 / Tape & Reel
NCP6868E315FCCT1G	WLCSP16 (Pb-Free)	3000 / Tape & Reel

†For information on tape and reel specifications, including part orientation and tape sizes, please refer to our Tape and Reel Packaging Specifications Brochure, BRD8011/D.

\* Consult Sales Office for specific Output Voltage requirement

# NCP6868

## PACKAGE DIMENSIONS

WLCSP16 1.80x1.80  
CASE 567JU  
ISSUE O

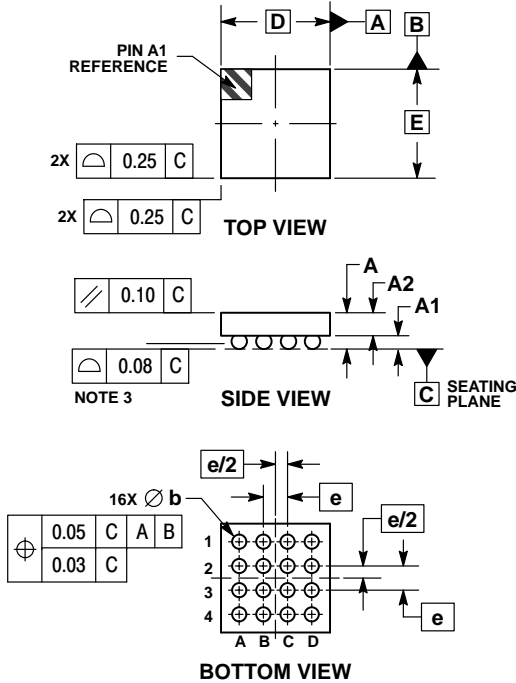

**NOTES:**

1. DIMENSIONING AND TOLERANCING PER ASME Y14.5M, 1994.
2. CONTROLLING DIMENSION: MILLIMETERS.
3. COPLANARITY APPLIES TO SPHERICAL CROWNS OF SOLDER BALLS.

DIM	MILLIMETERS	
	MIN	MAX
A	—	0.60
A1	0.17	0.23
A2	0.36 REF	
b	0.24	0.29
D	1.80 BSC	
E	1.80 BSC	
e	0.40 BSC	

**RECOMMENDED SOLDERING FOOTPRINT\***

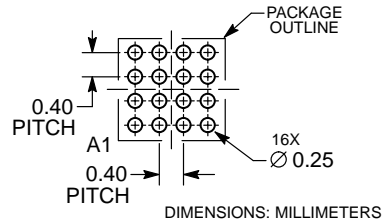

\*For additional information on our Pb-Free strategy and soldering details, please download the ON Semiconductor Soldering and Mounting Techniques Reference Manual, SOLDERRM/D.

ON Semiconductor and the are registered trademarks of Semiconductor Components Industries, LLC (SCILLC) or its subsidiaries in the United States and/or other countries. SCILLC owns the rights to a number of patents, trademarks, copyrights, trade secrets, and other intellectual property. A listing of SCILLC's product/patent coverage may be accessed at [www.onsemi.com/site/pdf/Patent-Marking.pdf](http://www.onsemi.com/site/pdf/Patent-Marking.pdf). SCILLC reserves the right to make changes without further notice to any products herein. SCILLC makes no warranty, representation or guarantee regarding the suitability of its products for any particular purpose, nor does SCILLC assume any liability arising out of the application or use of any product or circuit, and specifically disclaims any and all liability, including without limitation special, consequential or incidental damages. "Typical" parameters which may be provided in SCILLC data sheets and/or specifications can and do vary in different applications and actual performance may vary over time. All operating parameters, including "Typicals" must be validated for each customer application by customer's technical experts. SCILLC does not convey any license under its patent rights nor the rights of others. SCILLC products are not designed, intended, or authorized for use as components in systems intended for surgical implant into the body, or other applications intended to support or sustain life, or for any other application in which the failure of the SCILLC product could create a situation where personal injury or death may occur. Should Buyer purchase or use SCILLC products for any such unintended or unauthorized application, Buyer shall indemnify and hold SCILLC and its officers, employees, subsidiaries, affiliates, and distributors harmless against all claims, costs, damages, and expenses, and reasonable attorney fees arising out of, directly or indirectly, any claim of personal injury or death associated with such unintended or unauthorized use, even if such claim alleges that SCILLC was negligent regarding the design or manufacture of the part. SCILLC is an Equal Opportunity/Affirmative Action Employer. This literature is subject to all applicable copyright laws and is not for resale in any manner.

**PUBLICATION ORDERING INFORMATION**

**LITERATURE FULFILLMENT:**  
Literature Distribution Center for ON Semiconductor  
P.O. Box 5163, Denver, Colorado 80217 USA  
**Phone:** 303-675-2175 or 800-344-3860 Toll Free USA/Canada  
**Fax:** 303-675-2176 or 800-344-3867 Toll Free USA/Canada  
**Email:** [orderlit@onsemi.com](mailto:orderlit@onsemi.com)

**N. American Technical Support:** 800-282-9855 Toll Free  
USA/Canada  
**Europe, Middle East and Africa Technical Support:**  
Phone: 421 33 790 2910  
**Japan Customer Focus Center**  
Phone: 81-3-5817-1050

**ON Semiconductor Website:** [www.onsemi.com](http://www.onsemi.com)  
**Order Literature:** <http://www.onsemi.com/orderlit>  
For additional information, please contact your local Sales Representative