

Anschlussbereich verzinkt
terminal area tin plating

Koplanarität der Anschlüsse $\leq 0,1$ mm
coplanarity area of termination $\leq 0,1$ mm

Anforderungsstufe: 2
class: 2

234940	174416	Ø3,2			
223066	154190			#4-40	
	154189			M 3	
225043	154188	#4-40			
	154187	M 3			
Ident-Nr part-no. tape & reel	Ident-Nr part-no. tray	ohne without	Mutter thread	Bolzen bolt	Bemerkung remark

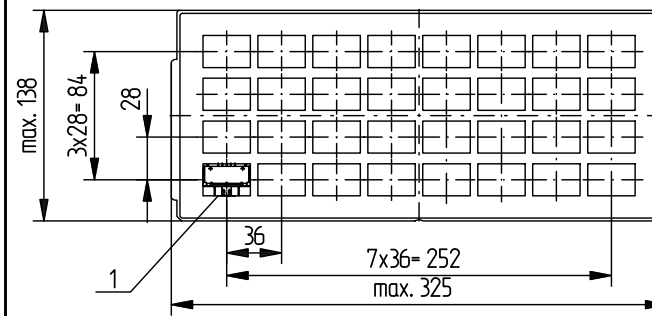

Verpackt in Tray
Verpackungseinheit 32 St.
tray packaging
packaging unit 32 pcs

Sonstige Angaben siehe 204629 / Additional indications please see 204629

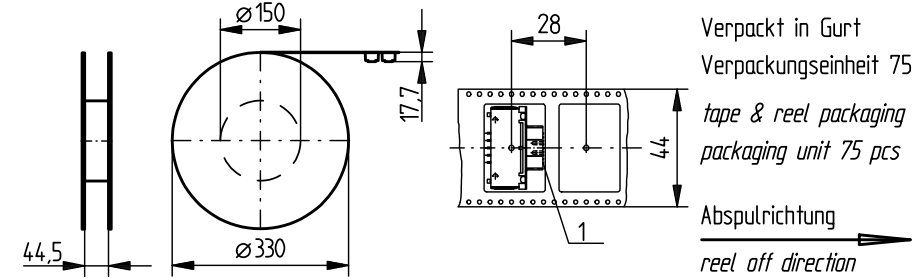

Verpackt in Gurt
Verpackungseinheit 75 St.
tape & reel packaging
packaging unit 75 pcs

Abspulrichtung
reel off direction

Sonstige Angaben siehe 204655 / Additional indications please see 204655

Layout

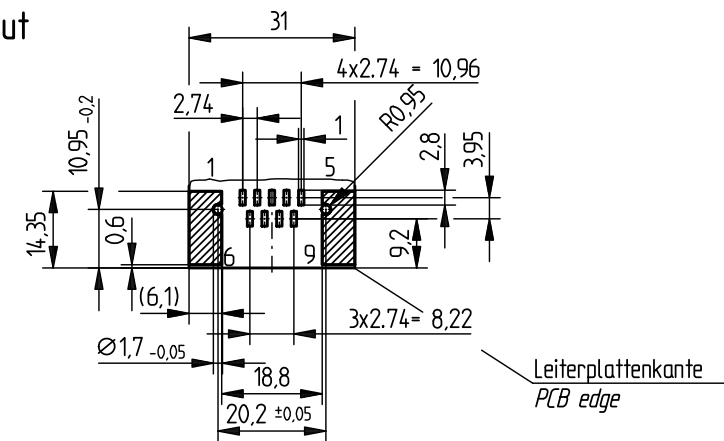

Fehlende Masse und Angaben siehe DIN 41652 / Missing information and dimensions according to DIN 41652

Sonstige Angaben siehe Fertigungsunterlagen / Additional indications please see the production documentation

Information:	Tolerances ISO 2768-m	 All Dimensions in mm	Scale	2:1
	Designation TMC-P 9-SMD-Standard TMC-P 9-SMD-Standard			
All rights reserved. Only for information. To insure that this is the latest version of this drawing, please contact one of the ERNI companies before using.		Subject to modification without prior notice. Drawing will not be updated.		144843
www.ERNI.com		V:00067302.SZA		TMCP
i	15.01.2009	Date		

Consider protection memo from DIN 34.