

MS18N50

500V N-channel MOSFET

Description

The MS18N50 is a N-channel enhancement-mode MOSFET, providing the designer with the best combination of fast switching, ruggedized device design, low on-resistance and cost effectiveness. The TO-220 package is universally preferred for all commercial-industrial applications

Features

- Originative New Design
- Very Low Intrinsic Capacitances
- Excellent Switching Characteristics
- 100% EAS Test
- Extended Safe Operating Area
- RoHS compliant package

Application

- High current, High speed switching
- PFC (Power Factor Correction)
- SMPS (Switched Mode Power Supplies)

Packing & Order Information

50/Tube ; 1,000/Box



**RoHS
COMPLIANT**

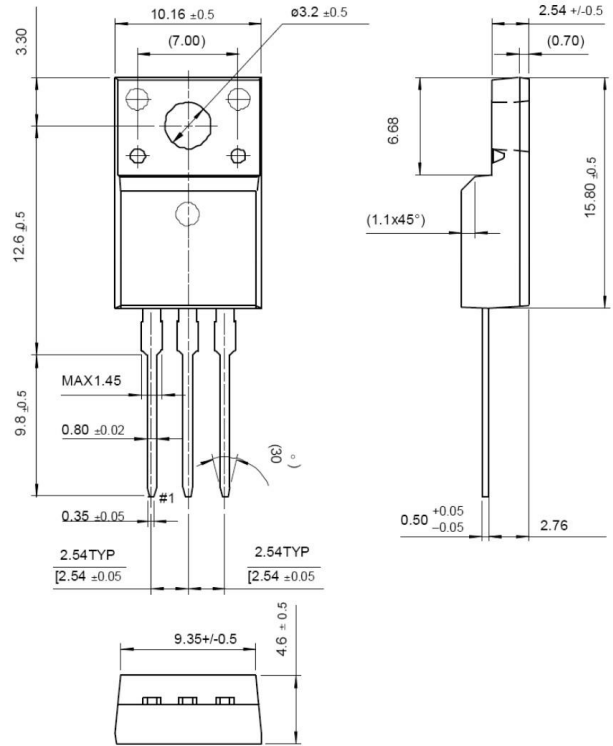

Graphic symbol

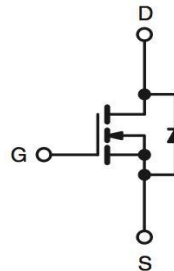

MAXIMUM RATINGS AND ELECTRICAL CHARACTERISTICS

Absolute Maximum Ratings

Symbol	Parameter	Value	Unit
V_{DS}	Drain-Source Voltage	500	V
V_{GS}	Gate-Source Voltage	±30	V
I_D	Drain Current -Continuous (TC=25°C)	18	A
	Drain Current -Continuous (TC=100°C)	10.8	A
I_{DM}	Drain Current -Pulsed	72	A
E_{AS}	Single Pulsed Avalanche Energy	990	mJ
E_{AR}	Repetitive Avalanche Energy	23.5	mJ
dV/dt	Peak Diode Recovery dV/dt	4.5	V/ns
T_J, T_{stg}	Operating Junction and Storage Temperature	-55~+150	°C
P_D	Power Dissipation (TC=25°C)	238	W
	Power Dissipation (TC=100°C)	1.8	W

- Drain current limited by maximum junction temperature

MS18N50

500V N-channel MOSFET

Thermal Characteristics

Symbol	Parameter	Value	Units
Rthjc	Thermal Resistance resistance	0.53	°C/W
RθJA	Thermal Resistance resistance	62.5	

Static Characteristics

Symbol	Test Conditions	Min	Typ.	Max.	Units
V_{GS}	$V_{DS} = V_{GS}, I_D = 250\mu A$	3.0		5.0	V
BV_{DSS}	$V_{GS} = 0 V, I_D = 250\mu A$	500	--	--	V
$\Delta BV_{DSS} / \Delta T_J$	$I_D = 250\mu A$, Referenced to 25°C	--	0.6	--	V/°C
I_{DSS}	$V_{DS} = 500 V, V_{GS} = 0 V$ $V_{DS} = 400 V, V_{GS} = 0 V, T_C = 125^\circ C$	--	--	1 10	μA
I_{GSSF}	$V_{GS} = -30 V, V_{DS} = 0 V$	--	--	100	nA
I_{GSSR}	$V_{GS} = -30 V, V_{DS} = 0 V$			-100	nA
* $R_{DS(ON)}$	$V_{GS} = 10 V, I_D = 9 A$	--	0.25	0.32	Ω

Dynamic Characteristics

Symbol	Test Conditions	Min	Typ.	Max.	Units
C_{ISS}	$V_{DS} = 25 V, V_{GS} = 0 V, f = 1.0 MHz$	--	2500	--	pF
C_{OSS}		--	400	--	pF
C_{RSS}		--	40	--	pF
$t_{d(on)}$	$V_{DD} = 250 V, I_D = 18 A, R_G = 25 \Omega$	--	70	--	ns
t_r		--	190	--	ns
$t_{d(off)}$		--	100	--	ns
t_f		--	100	--	ns
Q_g	$V_{DD} = 400 V, I_D = 18 A, V_{GS} = 10 V$	--	48.5	--	nC
Q_{gs}		--	14	--	nC
Q_{gd}		--	22	--	nC

Source-Drain Diode Characteristics

Symbol	Test Conditions	Min	Typ.	Max.	Units
I_S		--	--	18	A
I_{SM}		--	--	72	
V_{SD}	$I_S = 18 A, V_{GS} = 0 V$	--	--	1.5	V
t_{rr}	$I_F = 18 A, V_{GS} = 0 V$	--	550	--	ns
Q_{rr}	$diF/dt = 100 A/\mu s$	--	5.5	--	μC

MS18N50

500V N-channel MOSFET

Notes:

1. Repetitive Rating : Pulse width limited by maximum junction temperature
2. $L = 5.5\text{mH}$, $I_{AS} = 18.0\text{A}$, $V_{DD} = 50\text{V}$, $R_G = 25\Omega$, Starting $T_J = 25^\circ\text{C}$
3. $I_{SD} \leq 16.0\text{A}$, $di/dt \leq 200\text{A}/\mu\text{s}$, $V_{DD} \leq \text{BVDSS}$, Starting $T_J = 25^\circ\text{C}$
4. Pulse Test : Pulse Width $\leq 300\mu\text{s}$, Duty Cycle $\leq 2\%$
5. Essentially Independent of Operating Temperature

MS18N50

500V N-channel MOSFET

■ Characteristic Curves

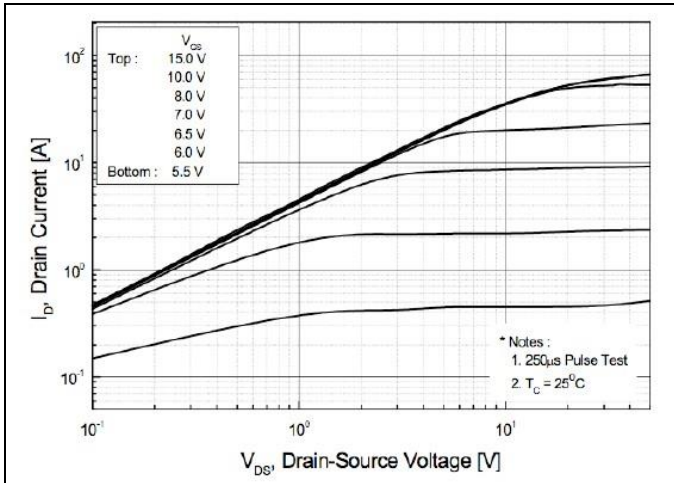

FIG.1-ON REGION CHARACTERISTICS

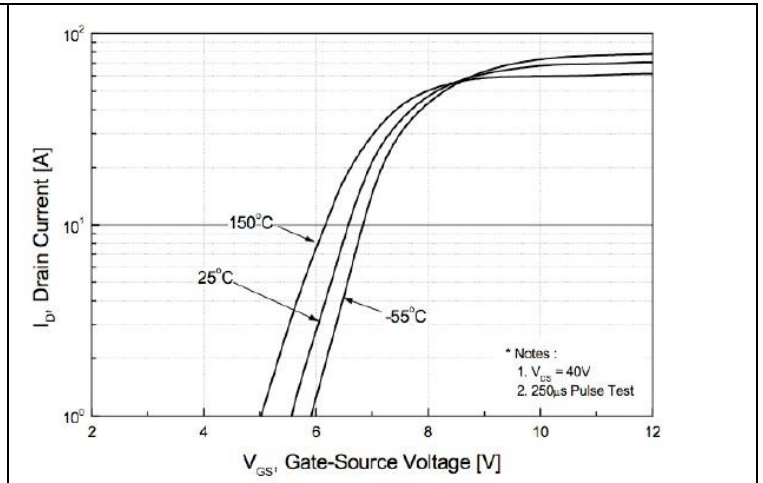

FIG.2-TRANSFER CHARACTERISTICS

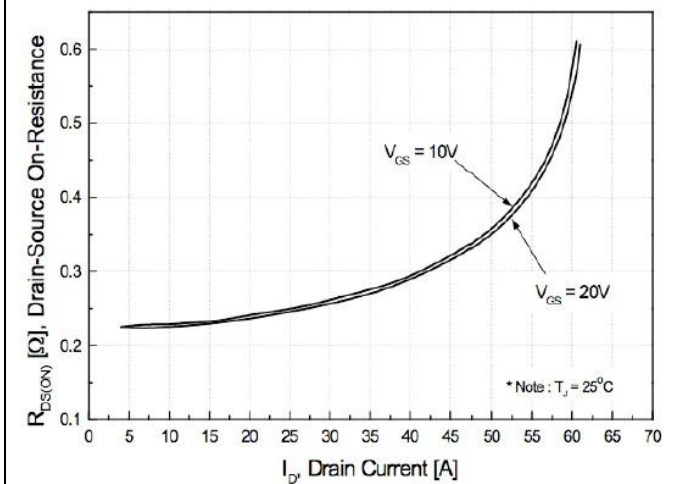

FIG.3-ON RESISTANCE VARIATION VS DRAIN CURRENT AND GATE VOLTAGE

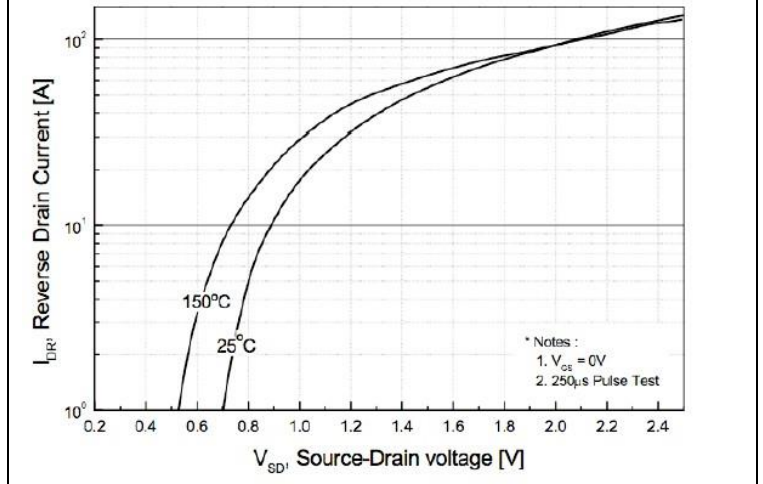

FIG.4-BODY DIODE FORWARD VOLTAGE VARIATION WITH SOURCE CURRENT AND TEMPERATURE

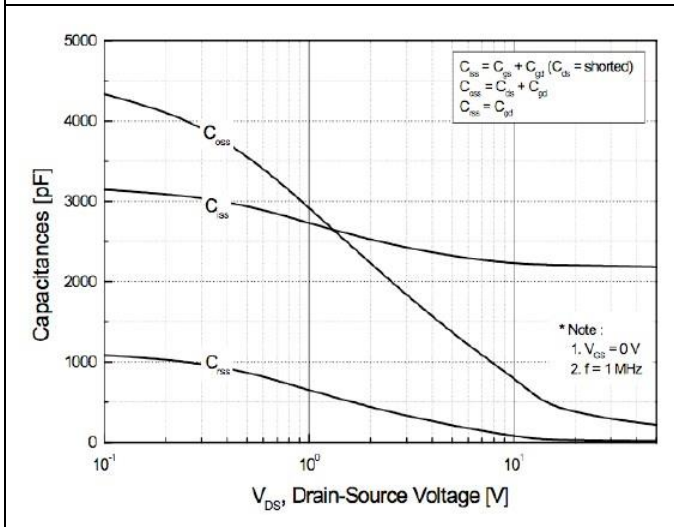

FIG.5-CAPACITANCE CHARACTERISTICS

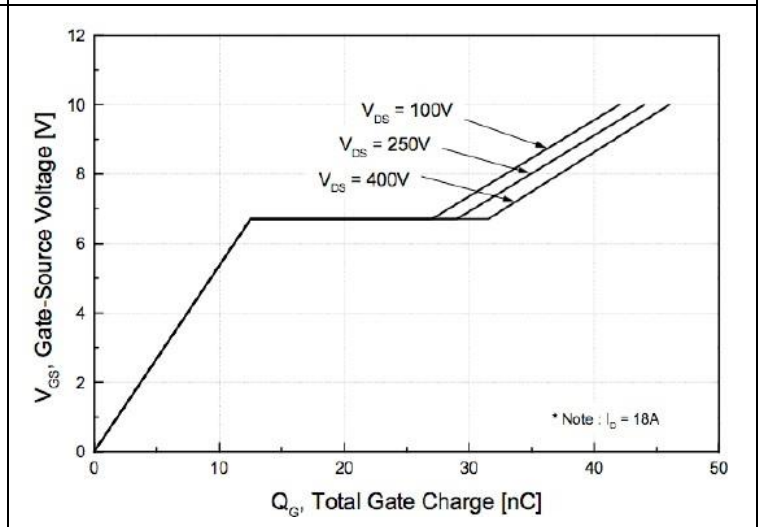

FIG.6-GATE CHARGE CHARACTERISTICS

MS18N50

500V N-channel MOSFET

Typical Electrical Characteristics

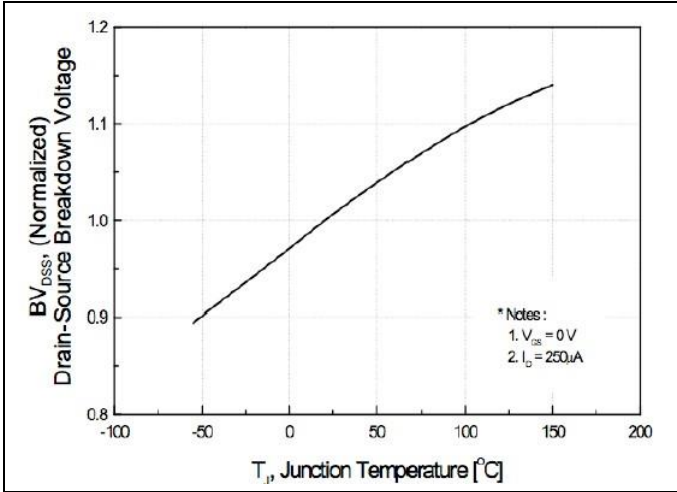

FIG.7-BREAKDOWN VOLTAGE VARIATION VS TEMPERATURE

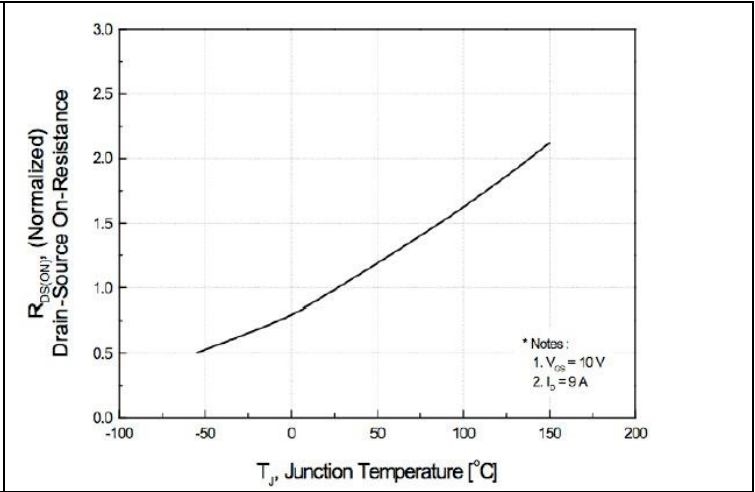

FIG.8-ON-RESISTANCE VARIATION VS TEMPERATURE

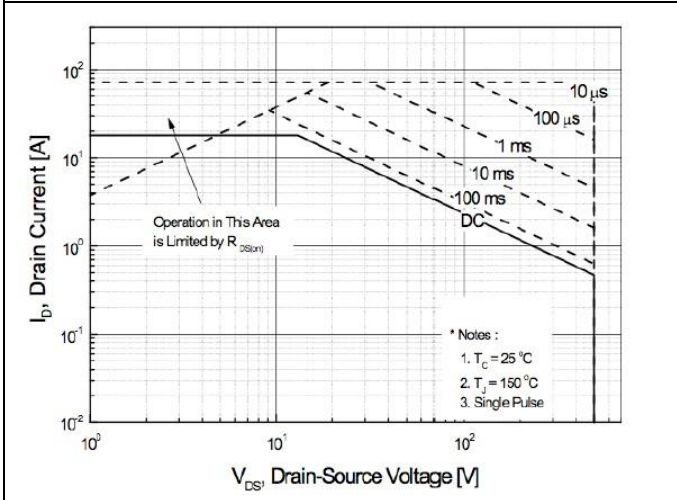

FIG.9-MAXIMUM SAFE OPERATING AREA

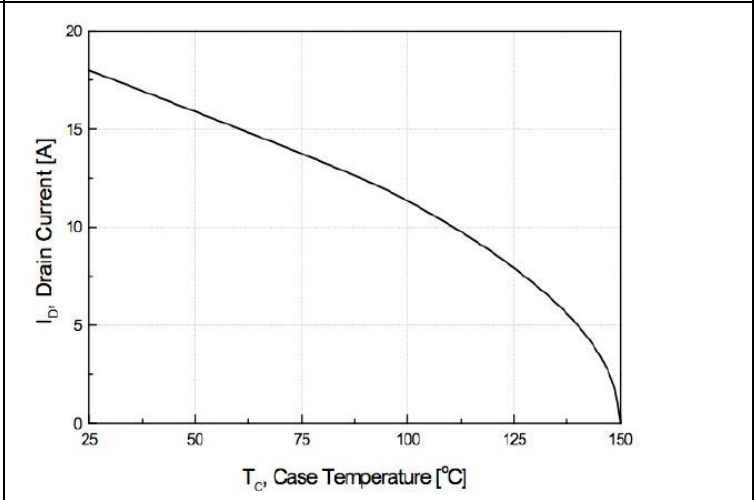

FIG.10-MAXIMUM DRAIN CURRENT VS CASE TEMPERATURE

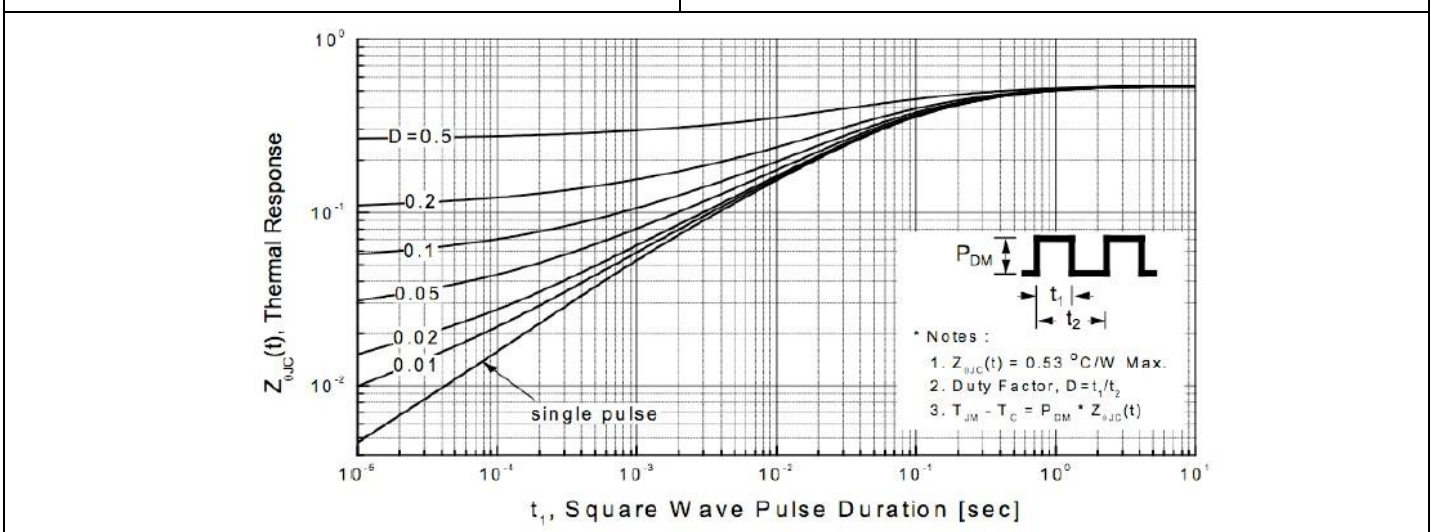

FIG.11-TRANSIENT THERMAL RESPONSE CURVE

MS18N50

500V N-channel MOSFET

■ Characteristics Test Circuit & Waveform

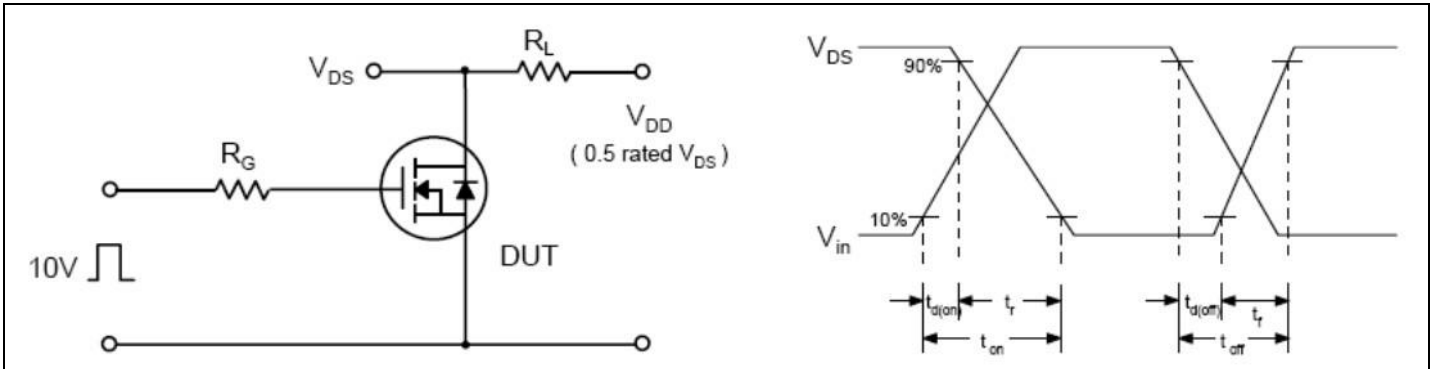

FIG.12-RESISTIVE SWITCHING TEST CIRCUIT & WAVEFORMS

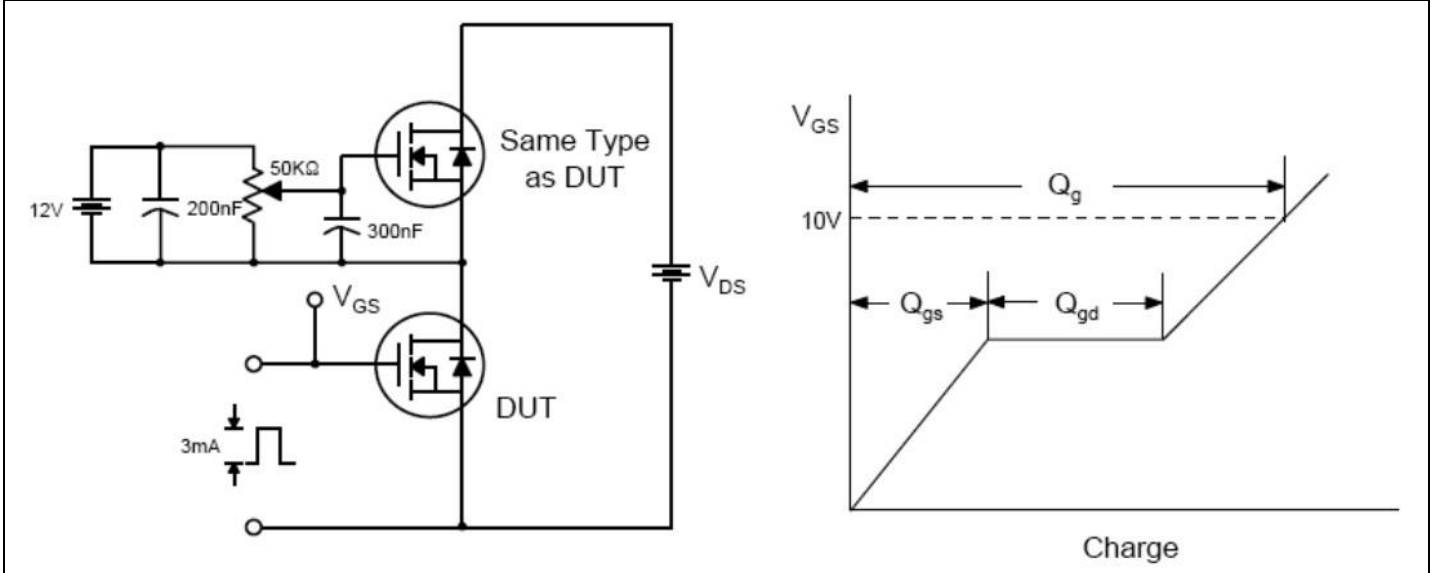

FIG.13-GATE CHARGE TEST CIRCUIT & WAVEFORM

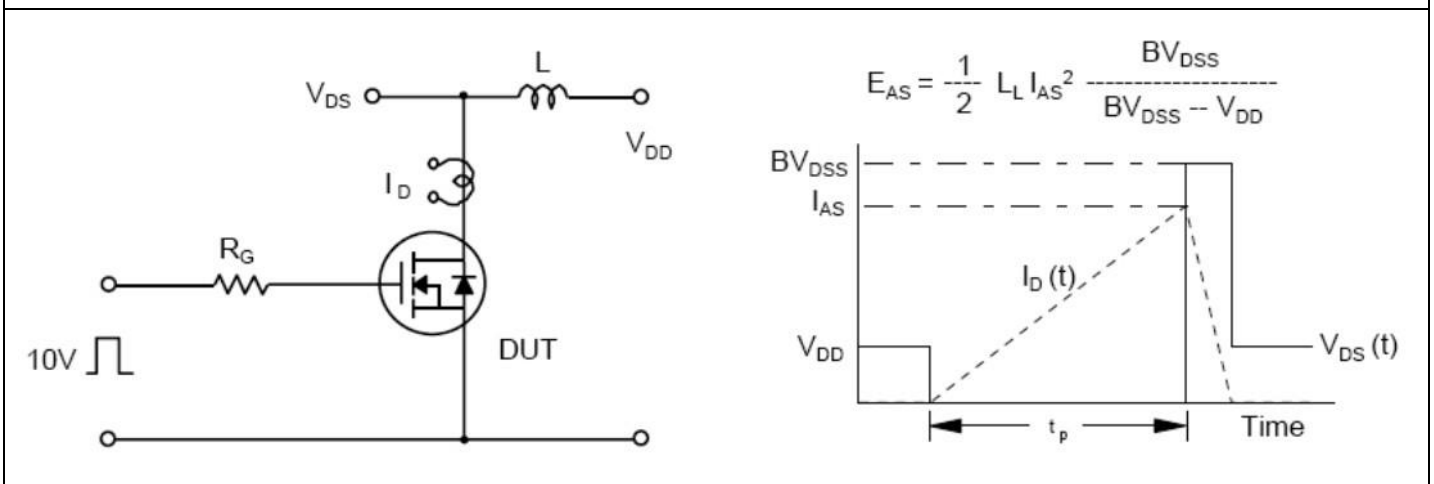

FIG.14-UNCLAMPED LINDUCTIVE SWITCHING TEST CIRCUIT & WAVEFORMS

MS18N50

500V N-channel MOSFET

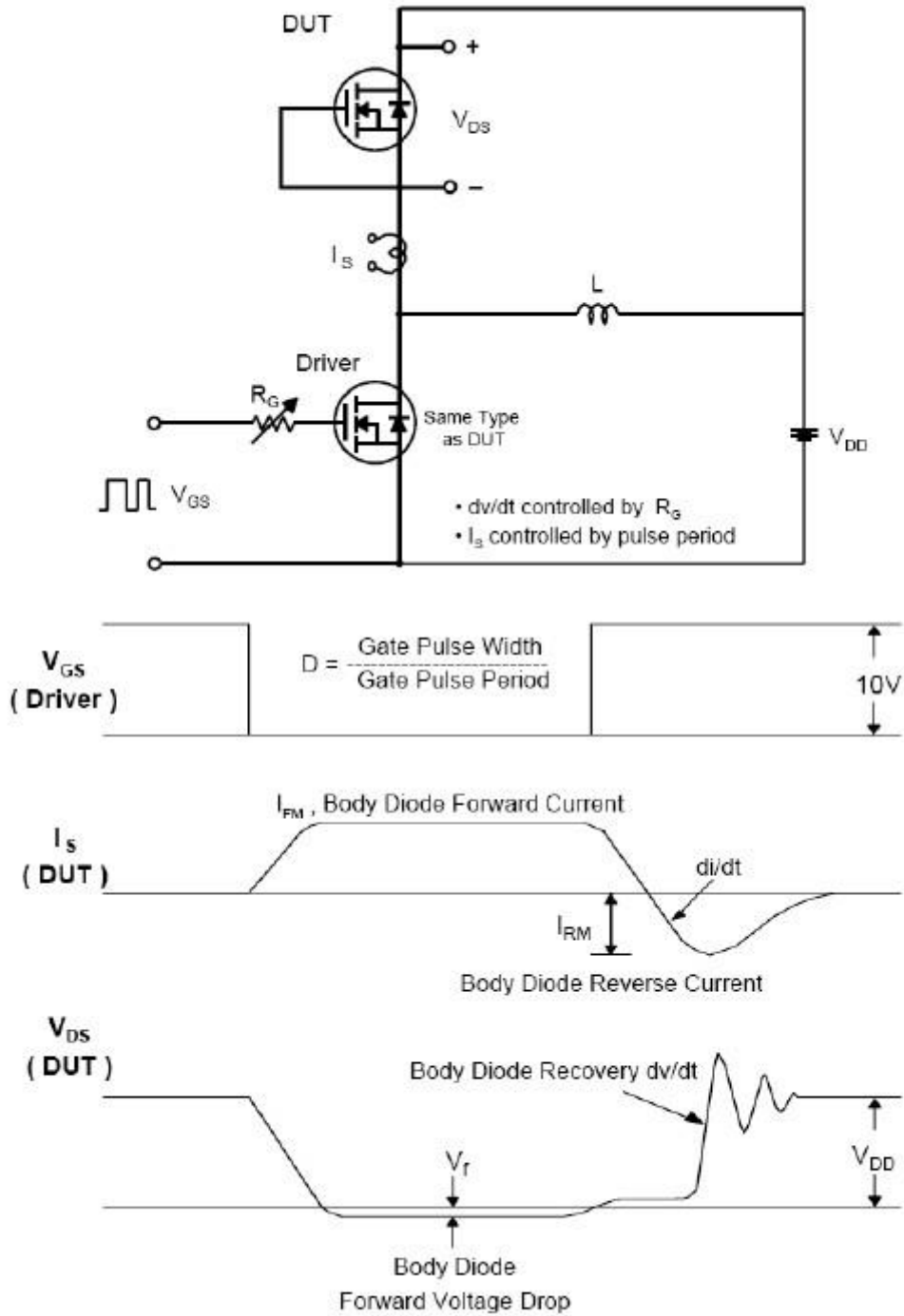

Fig 15. Peak Diode Recovery dv/dt Test Circuit & Waveforms

MS18N50

500V N-channel MOSFET

Disclaimer

ALL PRODUCT, PRODUCT SPECIFICATIONS AND DATA ARE SUBJECT TO CHANGE WITHOUT NOTICE TO IMPROVE RELIABILITY, FUNCTION OR DESIGN OR OTHERWISE.

Bruckewell Technology Inc., its affiliates, agents, and employees, and all persons acting on its or their behalf (collectively, "Bruckewell"), disclaim any and all liability for any errors, inaccuracies or incompleteness contained in any datasheet or in any other disclosure relating to any product.

Bruckewell makes no warranty, representation or guarantee regarding the suitability of the products for any particular purpose or the continuing production of any product. To the maximum extent permitted by applicable law, Bruckewell disclaims

- (i) Any and all liability arising out of the application or use of any product.
- (ii) Any and all liability, including without limitation special, consequential or incidental damages.
- (iii) Any and all implied warranties, including warranties of fitness for particular purpose, non-infringement and merchantability.

Statements regarding the suitability of products for certain types of applications are based on Bruckewell's knowledge of typical requirements that are often placed on Bruckewell products in generic applications.

Such statements are not binding statements about the suitability of products for a particular application. It is the customer's responsibility to validate that a particular product with the properties described in the product specification is suitable for use in a particular application. Parameters provided in datasheets and/or specifications may vary in different applications and performance may vary over time.

Product specifications do not expand or otherwise modify Bruckewell's terms and conditions of purchase, including but not limited to the warranty expressed therein.