

Keysight EEs of EDA

W1720EP Phased Array Beamforming Kit

W1467BP SystemVue Array Architect Bundle

System-level design support for phased array subsystems, enabling beamforming techniques to be applied to 5G, Radar, and Satellite systems

Solution Brochure

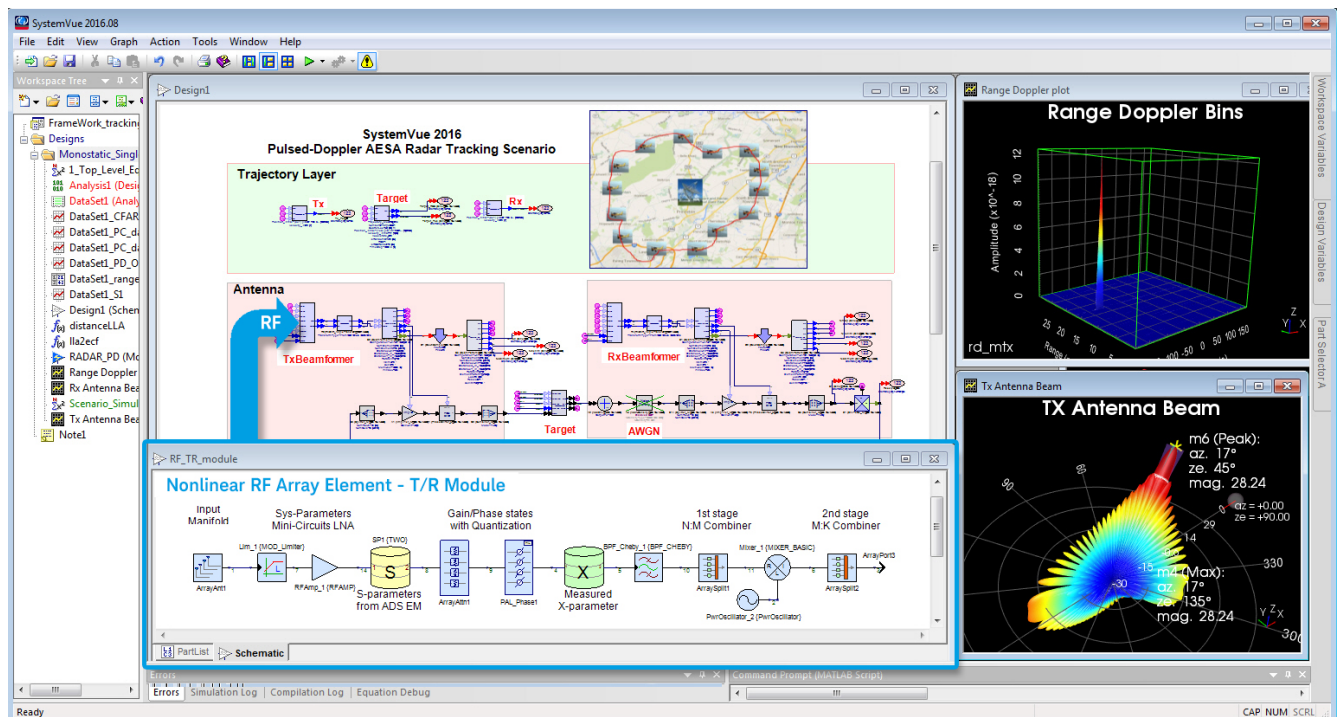

Unlocking Measurement Insights

Introduction

The W1720 Phased Array Beamforming Kit provides system architects in 5G, Radar/EW, and Satellite communications with the essential tools to evaluate phased array and beamforming subsystems, including RF, Digital, and Hybrid beamforming architectures. It allows system designers to consider RF nonlinear and noise effects, Gain/Phase quantization, and Monte Carlo variations effects on total beam quality, sidelobe levels, and effective radiated power. It also supports dynamic system-level scenarios with algorithms for adaptive beamforming.

Because SystemVue includes MATLAB Script and supports baseband algorithm modeling in multiple languages, such as C++, SystemC, and VHDL/Verilog, SystemVue is an ideal platform to cross-validate phased array design information from RF, Baseband, and test & measurement teams. The W1720 beamforming kit is also compatible with SystemVue's many reference libraries for 4G/5G, Radar, satellite, and other modulation formats.

Who should use the W1720 Phased Array Beamforming Kit?

In typical R&D organizations, many engineering disciplines are required in phased array subsystem design. The SystemVue Phased Array Beamforming Kit allows RF and baseband teams to use a model-based engineering approach across disciplines. This enables them to perform early R&D validation of phased array system architectures, components and beamforming algorithms, and then continue into hardware test.

- **System architects** can integrate design information from multiple diverse teams, along with test waveforms, to produce winning architectures and proposals
- **Algorithm and beamforming designers** can include RF design information, for more realistic accuracy
- **RF system architects** can directly observe the effects of their RF arrays on high-level beam-level measurements, such as beamwidth, sidelobe levels & nulls, effective radiated power (ERP), and Gain/Temperature (G/T)
- **System Verifiers** can validate scenario-level performance under a range of conditions, as well as automate regression suites, and link to high performance test and measurement equipment

SystemVue also provides a variety of links to RF design tools such as Keysight Advanced Design System (ADS), providing both flexibility and consistency across a full R&D workflow.

Key applications

- 5G beamforming and high order MIMO
- Radar/EW systems
- Automotive beamforming
- Satellite/NewSpace communications terminals and payloads

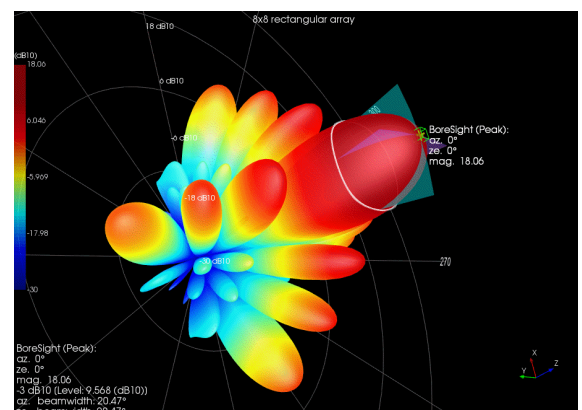

What's Included in the W1720?

The W1720 adds onto any SystemVue environment. It enables users to work with phased arrays as either individual signals, or as a single “beam”. The W1720 includes

- RF array analysis – enhances W1719 Spectrasys to work with arrays. Replaces ad hoc spreadsheets with nonlinear RF analysis for N-element arrays used in RF beamforming, with multiple levels of splitters/combiners, gain/phase states, and impairments from nonlinear, mismatch, and noise effects. (requires W1719).
- Dataflow array analysis – Models dynamic RF, Digital, and Hybrid beamforming topologies, and provides a convenient “Timed Envelope Matrix” datatype that makes working with 1000 parallel signal paths as easy as 1 signal path.
- RF Link – allows the RF array to be re-used at the system dataflow level. Directly validate nonlinear Transmit/Receiver architectures on actual 5G, Radar/EW, or Satellite system performance using realistic signals with active modulation, coding, and adaptive equalization and filtering.
- Beam measurements and visualization – Direct measurements of beamwidth, boresight direction, sidelobe levels, nulls, and aggregate quantities such as directivity, G/T, and effective radiated power.
- System-level scenarios – Apply beamforming subsystems in active, system-simulation scenarios in 5G, Radar/EW, and Satellite communications.

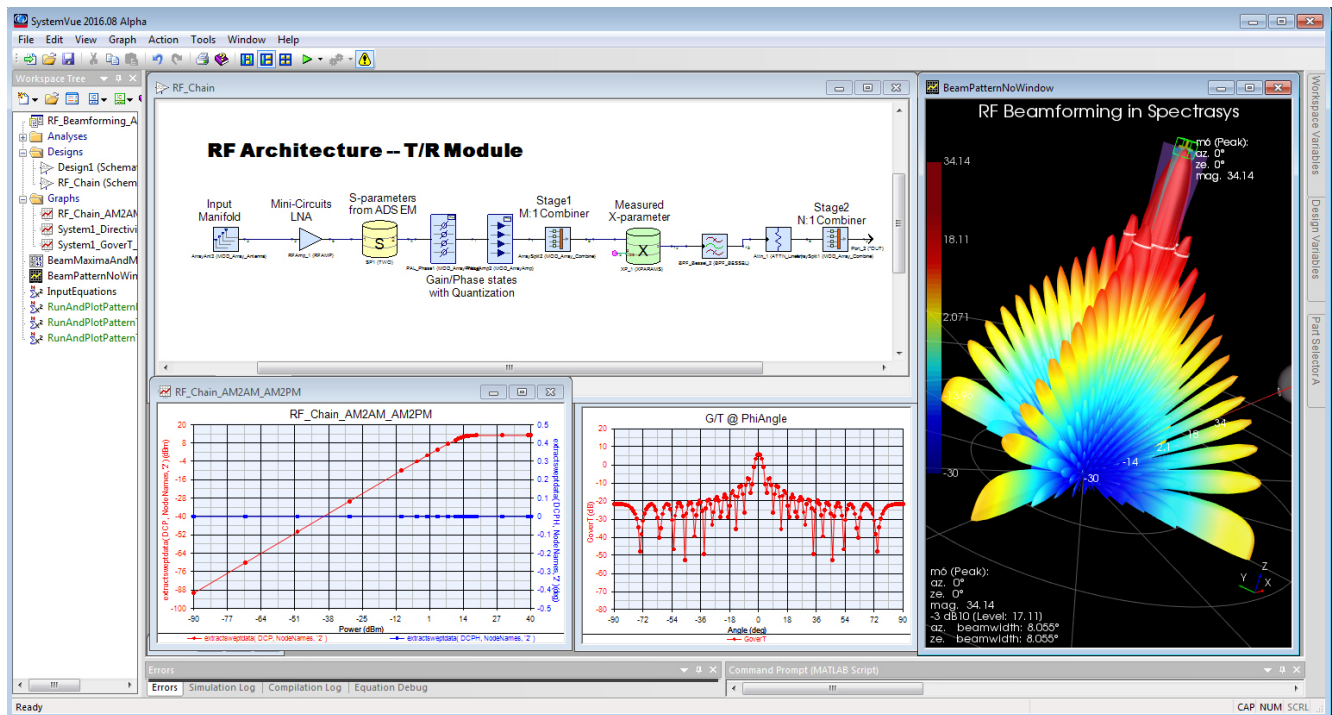

Figure 1. Among its many functions, the W1720 Phased Array Beamforming Kit adds an array analysis controller and special components and measurements to the W1719 RF System Design Kit (Spectrasys). If you already own the W1719, the W1720 adds on top, and enables the full dynamic dataflow capability as well.

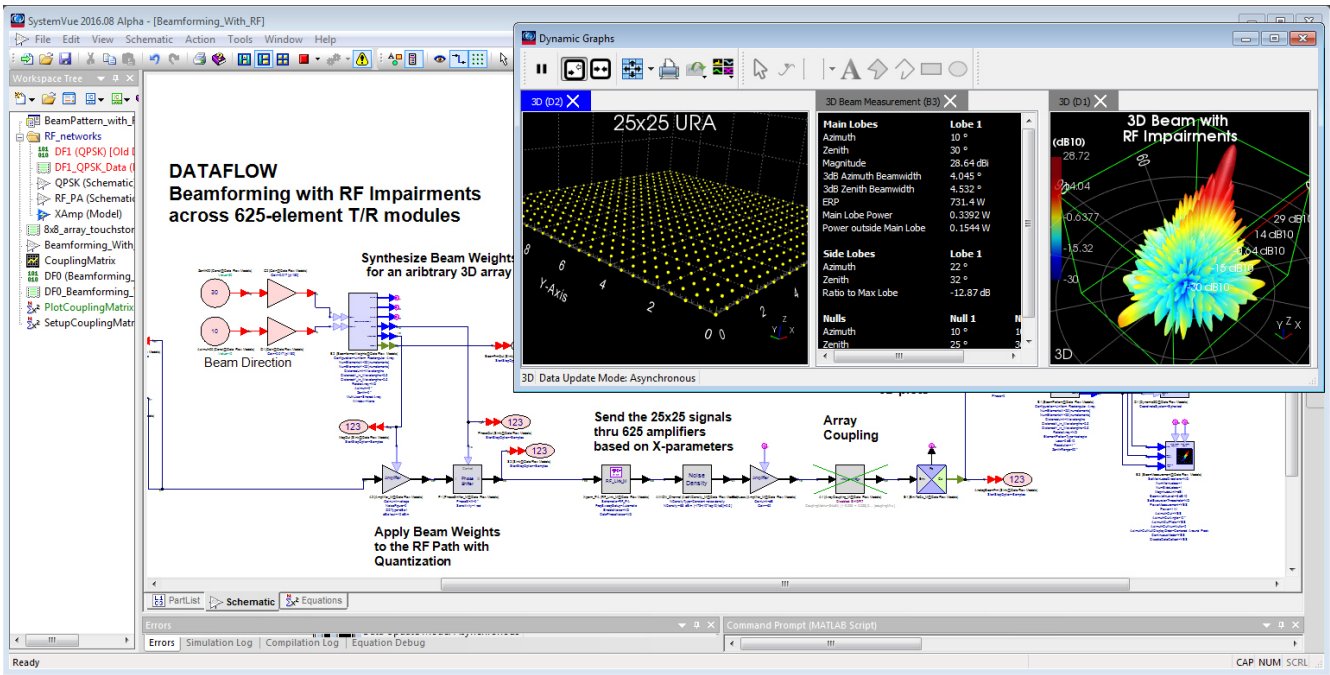

Figure 2. The W1720 also enables a dynamic, system-level beamforming analysis using a new “timed envelope matrix” datatype in the dataflow simulation. Observe dynamic measurements of beamwidth, direction, sidelobe levels, and nulls, while taking into account quantization effects, noise, nonlinearities, statistical variations, and farfield patterns from popular 3DEM software.

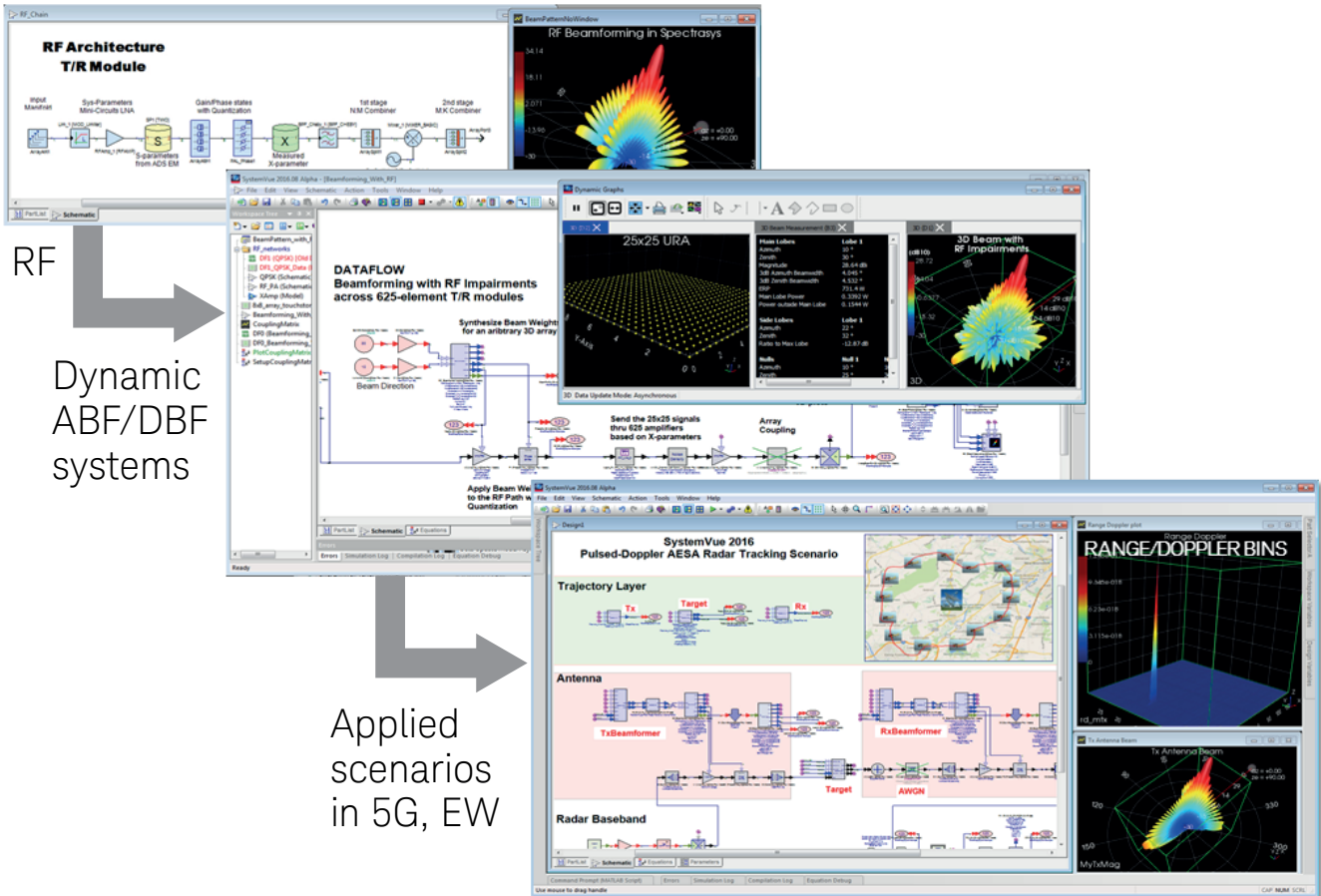

Figure 3. The W1720 allows RF array performance to be leverage at the dataflow (system-level), and then applied to dynamic, multi-user scenarios with active signaling using the SystemVue 5G, Radar, and other reference libraries. Shown above is a monostatic radar tracking application using the W1905 Radar model library.

Configuration

The W1720 Phased Array Beamforming Kit can be added to any SystemVue Environment. It does not require the W1719 RF System Design Kit, but the W1719 is highly recommended for analysis of RF array architectures. Without the W1719, the W1720 still provides system-level dataflow simulations and beam measurements.

If you are working in Radar or 5G applications, it is recommended that you purchase the full W1905 or W1906 libraries (respectively), not the W1720 by itself.

The W1720 is already included in these bundles and libraries:

- W1905 Radar Model library
- W1906 5G baseband verification library
- W1907 5G Forward baseband verification library bundle
- W1467 SystemVue Array Architect bundle

The W1467 SystemVue Array Architect is a convenient bundle that adds the W1720 Phased Array Beamforming Kit to the popular W1464 SystemVue RF System Architect bundle, to take full advantage of the W1720. This bundle is recommended for system architects working in satellite and New Space communications systems. Existing SystemVue users may wish to upgrade to this bundle.

The W1467 includes:

- W1461 SystemVue Comms Architect
- W1719 RF System Design Kit
- W1720 Phased Array Beamforming Kit

Additional Keysight software applications (such as I/O libraries, Command Expert, and the 89600 VSA software) are often used to connect SystemVue to families of Keysight test equipment. These families include baseband AWGs, digitizers, RF sources, RF analyzers, and oscilloscopes.

For More Information

For more detailed application information, refer to:

- www.keysight.com/find/eesof-systemvue-phased-array
- www.keysight.com/find/eesof-systemvue-videos
- www.keysight.com/find/eesof-systemvue-evaluation

Download your next insight

Keysight software is downloadable expertise. From first simulation through first customer shipment, we deliver the tools your team needs to accelerate from data to information to actionable insight.

- Electronic design automation (EDA) software
- Application software
- Programming environments
- Utility software



Learn more at www.keysight.com/find/software
 Start with a 30-day free trial. www.keysight.com/find/free_trials

For more information on Keysight Technologies' products, applications or services, please contact your local Keysight office. The complete list is available at: www.keysight.com/find/contactus

Americas

Canada	(877) 894 4414
Brazil	55 11 3351 7010
Mexico	001 800 254 2440
United States	(800) 829 4444

Asia Pacific

Australia	1 800 629 485
China	800 810 0189
Hong Kong	800 938 693
India	1 800 11 2626
Japan	0120 (421) 345
Korea	080 769 0800
Malaysia	1 800 888 848
Singapore	1 800 375 8100
Taiwan	0800 047 866
Other AP Countries	(65) 6375 8100

Europe & Middle East

Austria	0800 001122
Belgium	0800 58580
Finland	0800 523252
France	0805 980333
Germany	0800 6270999
Ireland	1800 832700
Israel	1 809 343051
Italy	800 599100
Luxembourg	+32 800 58580
Netherlands	0800 0233200
Russia	8800 5009286
Spain	800 000154
Sweden	0200 882255
Switzerland	0800 805353
	Opt. 1 (DE)
	Opt. 2 (FR)
	Opt. 3 (IT)
United Kingdom	0800 0260637

For other unlisted countries:
www.keysight.com/find/contactus
 (BP-02-10-16)

From Hewlett-Packard through Agilent to Keysight

For more than 75 years, we've been helping you unlock measurement insights. Our unique combination of hardware, software and people can help you reach your next breakthrough. **Unlocking measurement insights since 1939.**

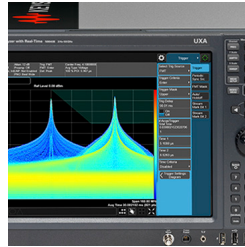
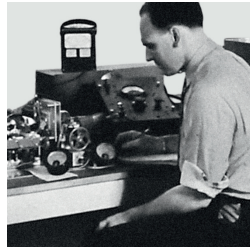

myKeysight
www.keysight.com/find/mykeysight
 A personalized view into the information most relevant to you.