

BM831

Mixer

0.7~1.4GHz High IIP3 GaAs MMIC Mixer with Integrated LO AMP



Device Features

- +31.7 dBm Input IP3
- 8.8dB Conversion Loss
- Integrated LO Driver
- -2 to +2dBm LO drive level
- Available 3.3V to 5V single voltage
- MSL 1, MSOP 8, Lead-free / Green / RoHS compliant
- ESD HBM Class 1B



MSOP 8 Package

Product Description

The BM831 is a high linearity and dynamic covering range from 0.7GHz to 1.4GHz on 3.3V to 5V with a passive GaAs FET converter and two stage LO driver. This is packaged in a plastic surface mountable MSOP8 with Lead-free / Green / RoHS compliant. Typical Input IP3 and Conversion loss are 31.7dBm and 8.8dB, respectively. All devices are 100% RF/DC screened.

Functional Block Diagram

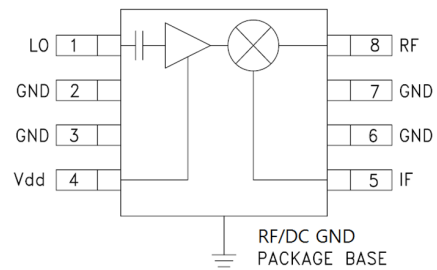

Applications

- Base station /Repeaters Infrastructure/Small Cell
- Commercial/Industrial/Military wireless system
- LTE / WCDMA /CDMA Wireless Infrastructure

Application Circuit

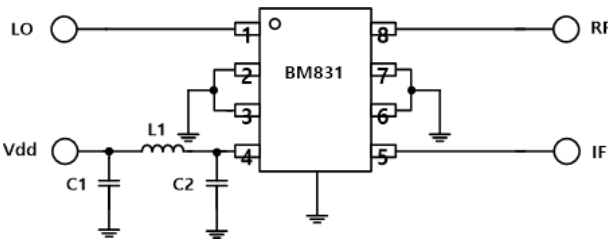

IF Frequency	BOM	Value
50~100MHz	C1	1nF
	C2	-
	L1	56nH
100~210MHz	C1	-
	C2	1nF
	L1	56nH

* Notices

- Pls use 0.15T metal thickness for SMT
- See page 15 for more detail

Absolute Maximum Ratings

Parameter	Rating	Unit
Operating Case Temperature	-40 to +85	°C
Storage Temperature	-55 to +155	°C
Junction Temperature	+126	°C
Operating Voltage	+7	V
LO Power	+10	dBm
Input RF/IF Power	+25	dBm

Operation of this device above any of these parameters may result in permanent damage.

Preliminary Datasheet

BM831



Mixer

0.7~1.4GHz High IIP3 GaAs MMIC Mixer with Integrated LO AMP

Typical Performance¹

Test condition _ Measured on BeRex E/B at 25°C, 50ohm system, Vdd=5V I_{ds}=58mA

Parameter	Min	Typ	Max	Min	Typ	Max	Min	Typ	Max	Min	Typ	Max	Min	Typ	Max	Units
RF Frequency Range	700~800			800~900			900~1000			1000~1100			1100~1400			MHz
LO Frequency Range	750~1010			850~1110			950~1210			1050~1310			1150~1610			MHz
IF Frequency Range	50~210			50~210			50~210			50~210			50~210			MHz
SSB Conversion Loss		10.1			9.1			8.8			8.9			9.3		dB
Input IP ₃ ²		30.3			31.7			31.7			32.6			32.6		dBm
LO Leakage RF Port		-9.1			-7.2			-6.0			-4.5			-2.8		dBm
LO Leakage IF Port		-15.0			-17.7			-18.7			-16.5			-11.1		dBm
RF-IF Isolation		-20.0			-22.4			-25.6			-25.9			-20.3		dB
RF Return Loss		-11.7			-14.7			-16.0			-16.0			-14.6		dB
IF Return Loss		-10.0			-9.0			-8.5			-8.6			-9.8		dB
Input P _{1dB}		23.7			24.2			24.5			24.3			24.0		dBm
LO Drive Level	-2	0	+2	-2	0	+2	-2	0	+2	-2	0	+2	-2	0	+2	dBm

Test condition _ Measured on BeRex E/B at 25°C, 50ohm system, Vdd=3.3V I_{ds}= 45mA

Parameter	Min	Typ	Max	Min	Typ	Max	Min	Typ	Max	Min	Typ	Max	Min	Typ	Max	Units
RF Frequency Range	700~800			800~900			900~1000			1000~1100			1100~1400			MHz
LO Frequency Range	750~1010			850~1110			950~1210			1050~1310			1150~1610			MHz
IF Frequency Range	50~210			50~210			50~210			50~210			50~210			MHz
SSB Conversion Loss		10.0			9.0			8.8			9.0			9.7		dB
Input IP ₃ ²		32.8			28.5			28.5			28.5			30.3		dBm
LO Leakage RF Port		-11.3			-9.9			-8.9			-7.8			-5.9		dBm
LO Leakage IF Port		-18.1			-21.3			-22.5			-20.3			-15.0		dBm
RF-IF Isolation		-19.1			-22.0			-25.3			-25.5			-19.7		dB
RF Return Loss		-15.3			-19.3			-20.3			-18.1			-15.2		dB
IF Return Loss		-9.0			-7.6			-7.2			-7.7			-7.4		dB
Input P _{1dB}		18.9			19.1			19.1			18.6			17.9		dBm
LO Drive Level	-2	0	+2	-2	0	+2	-2	0	+2	-2	0	+2	-2	0	+2	dBm

Parameter	Min.	Typical	Max.	Unit
Bandwidth	700		1400	MHz
I _d @ (V _d = 5.0V)		58.0		mA
I _d @ (V _d = 3.3V)		45.0		mA
R _{TH}		99.0		°C/W

¹ Specifications show on 0dBm-LO driven power and 50 MHz-IF frequency in a down converting configuration with high-side LO.

² IIP₃ is measured on two tone with RF in power 0dBm/ tone, F₂-F₁ = 1 MHz..

BM831

Mixer

0.7~1.4GHz High IIP3 GaAs MMIC Mixer with Integrated LO AMP



Typical Test Data

Test condition _ Measured on BeRex E/B at 25°C, 50ohm system, Vdd=5V, Ids=58mA , Down converting

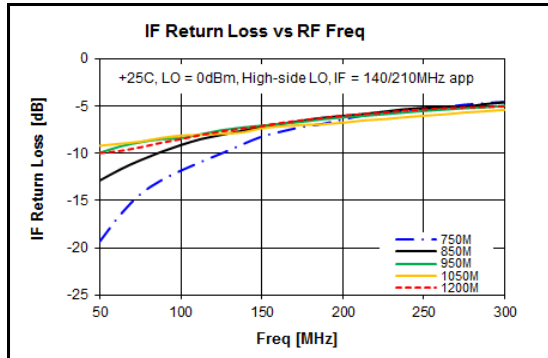
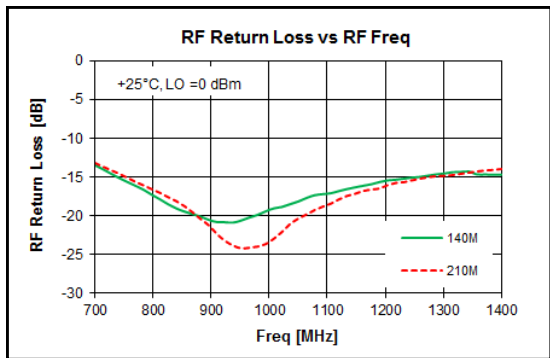
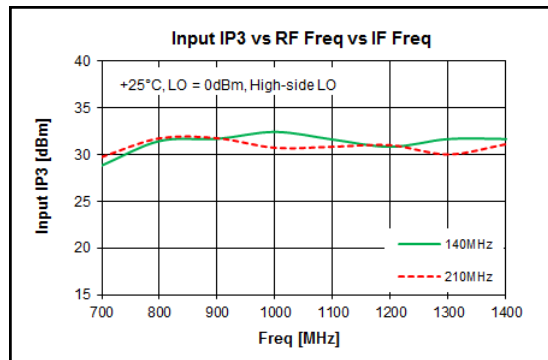
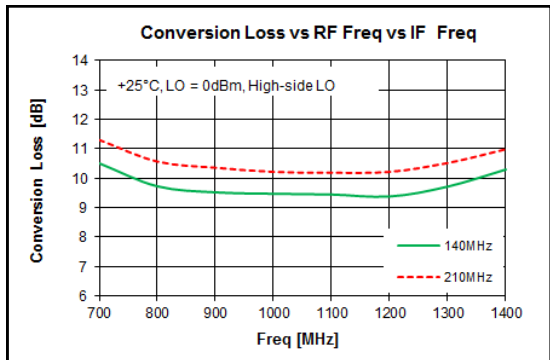
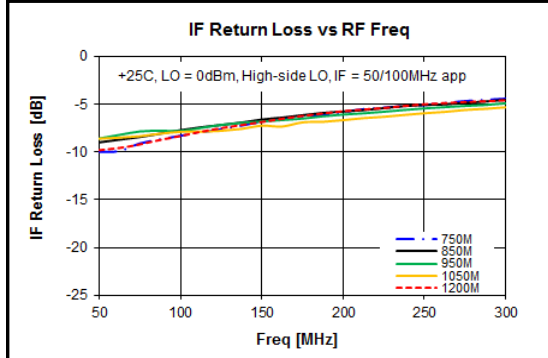
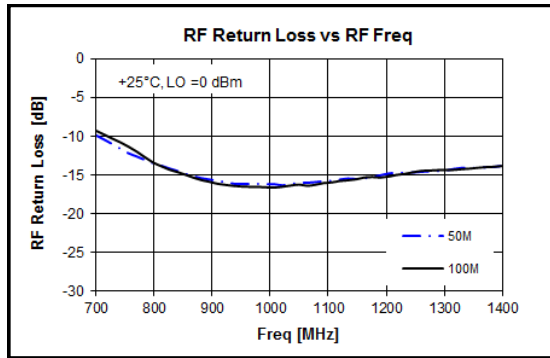
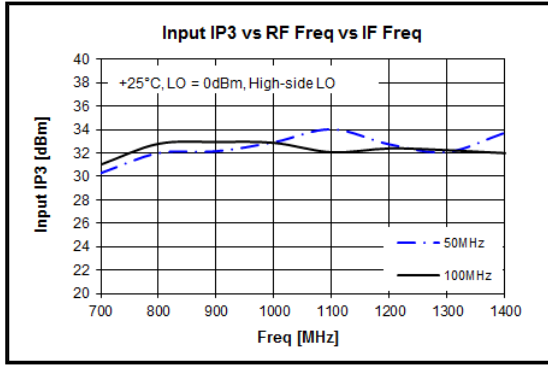
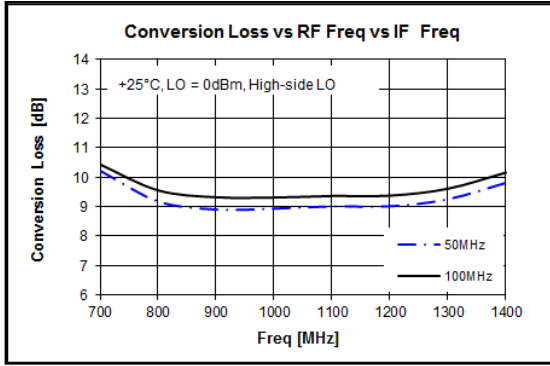

Preliminary Datasheet

BM831

Mixer

0.7~1.4GHz High IIP3 GaAs MMIC Mixer with Integrated LO AMP



Typical Test Data

Test condition _ Measured on BeRex E/B at 25°C, 50ohm system, Vdd=5V, Ids=58mA , Down converting

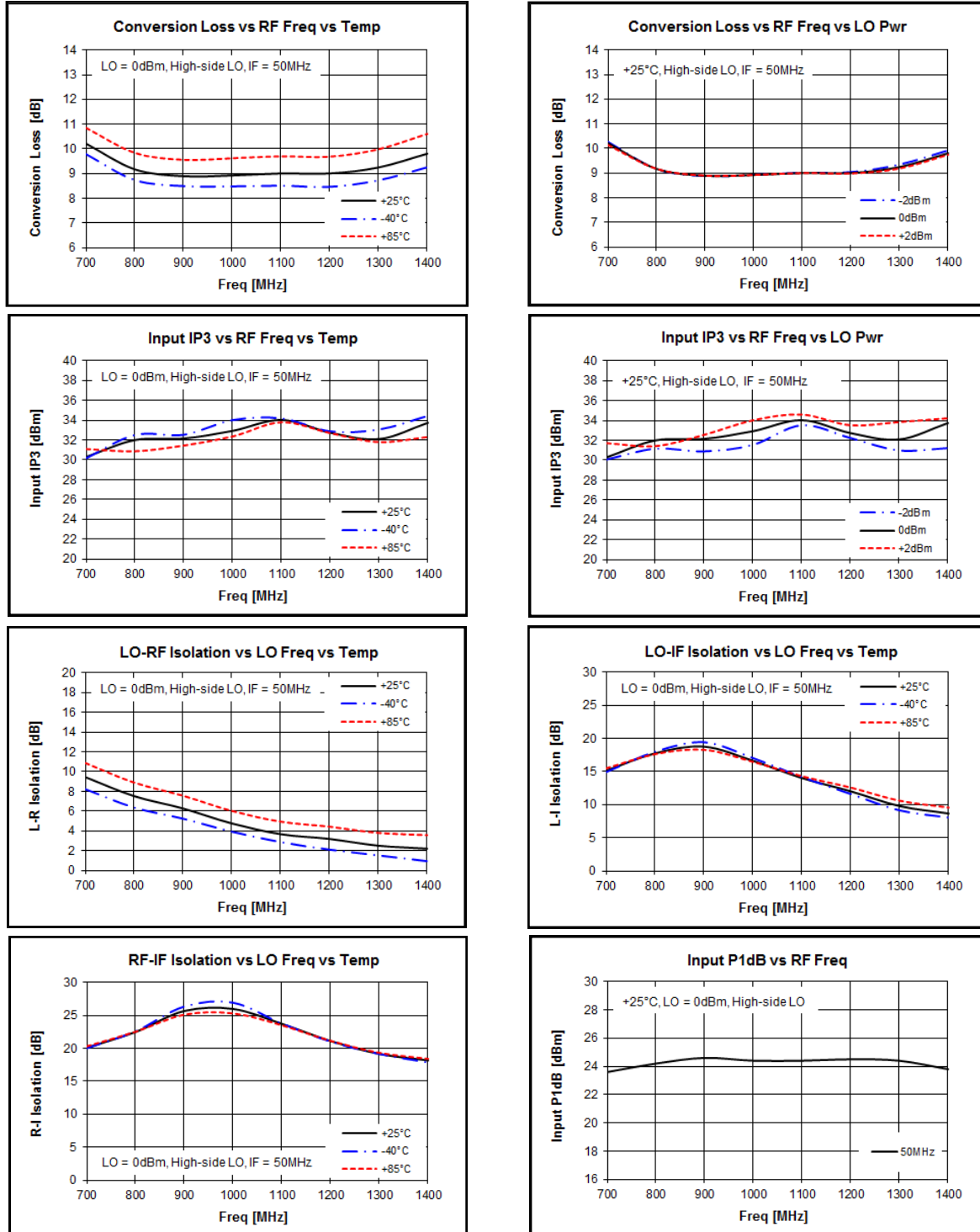

Preliminary Datasheet

BM831

Mixer

0.7~1.4GHz High IIP3 GaAs MMIC Mixer with Integrated LO AMP



Typical Test Data

Test condition _ Measured on BeRex E/B at 25°C, 50ohm system, Vdd=5V, Ids=58mA , Down converting

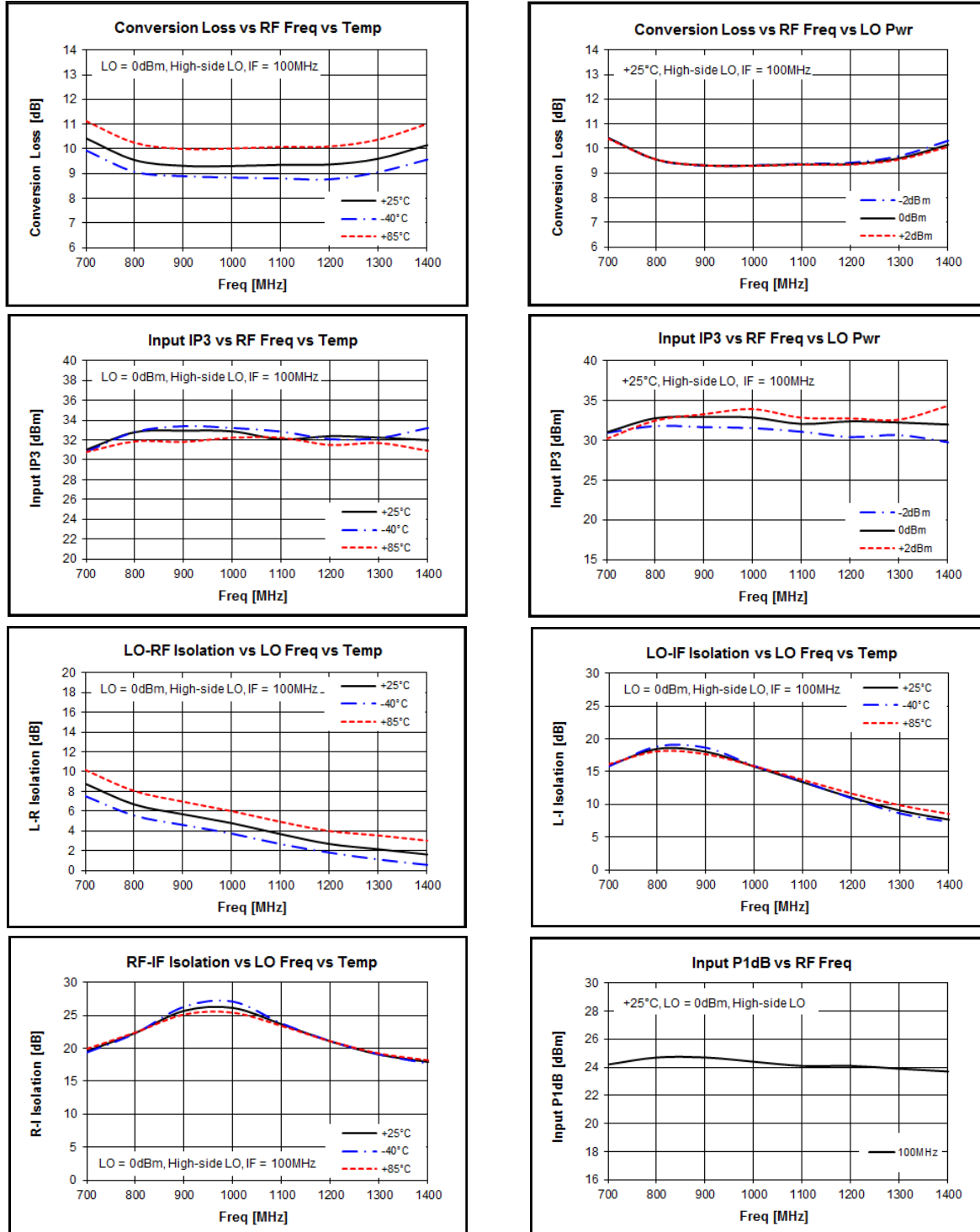

Preliminary Datasheet

BM831

Mixer

0.7~1.4GHz High IIP3 GaAs MMIC Mixer with Integrated LO AMP



Typical Test Data

Test condition _ Measured on BeRex E/B at 25°C, 50ohm system, Vdd=5V, Ids=58mA , Down converting

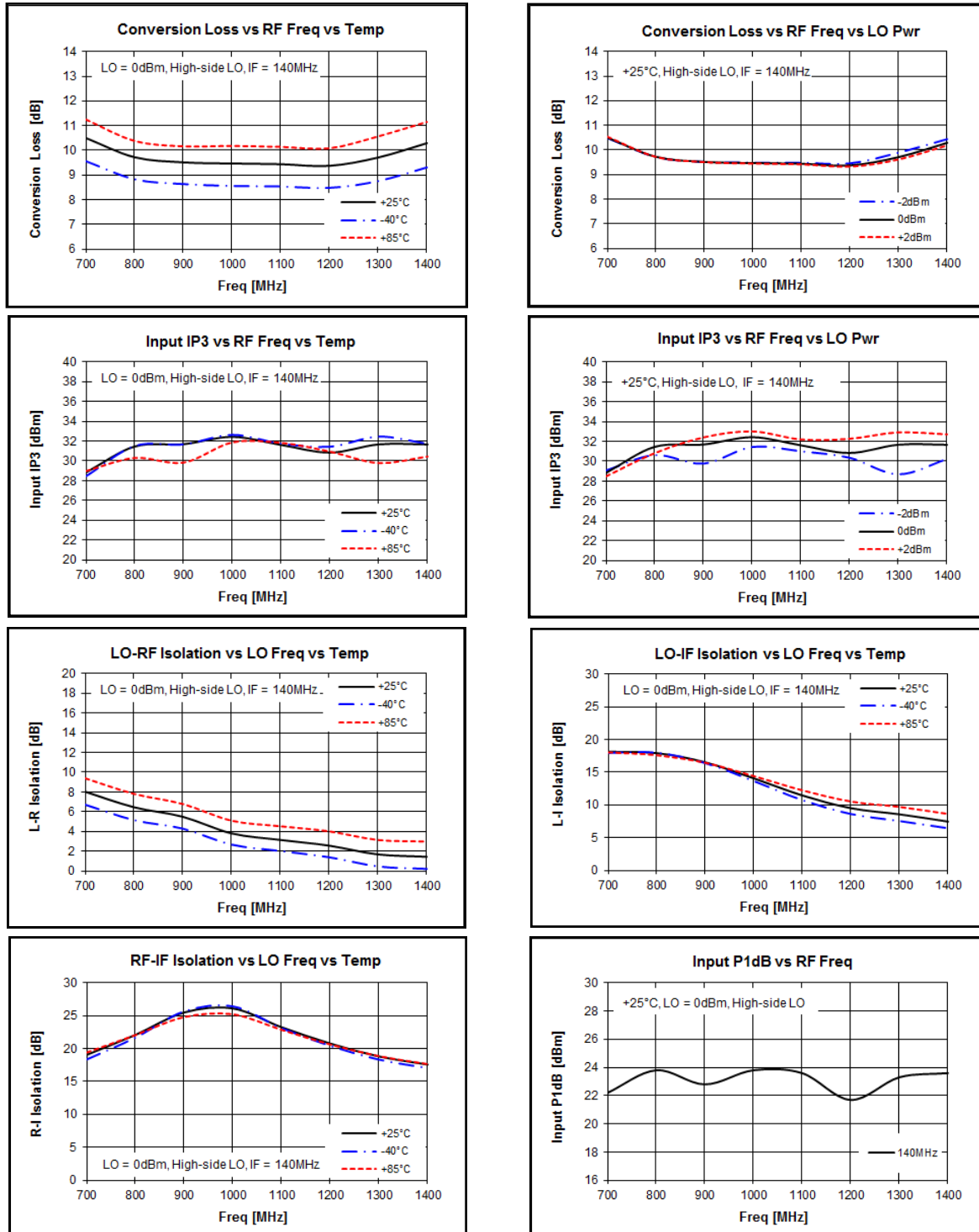

Preliminary Datasheet

BM831

Mixer

0.7~1.4GHz High IIP3 GaAs MMIC Mixer with Integrated LO AMP



Typical Test Data

Test condition _ Measured on BeRex E/B at 25°C, 50ohm system, Vdd=5V, Ids=58mA , Down converting

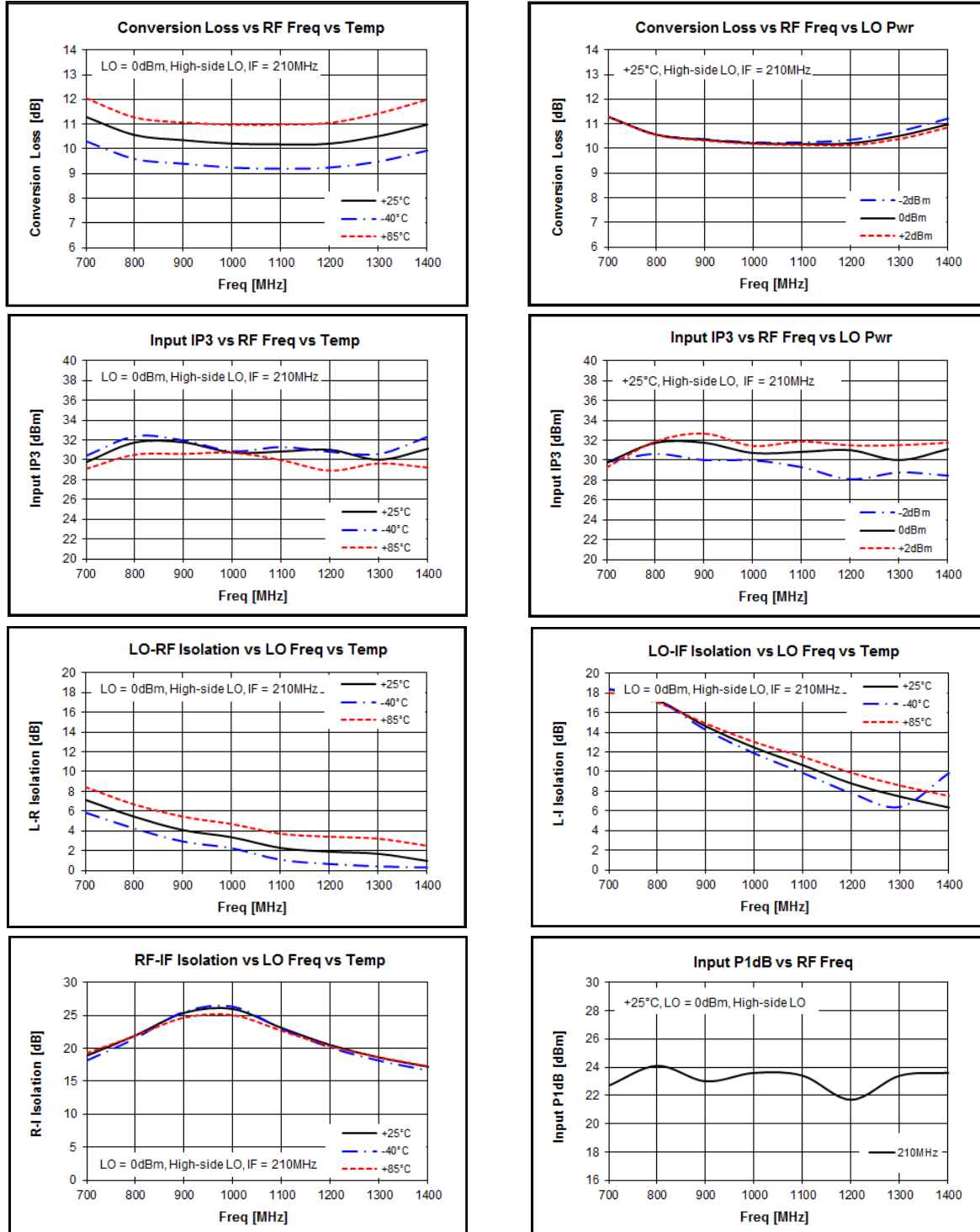

Preliminary Datasheet

BM831

Mixer

0.7~1.4GHz High IIP3 GaAs MMIC Mixer with Integrated LO AMP



Typical Test Data

Test condition _ Measured on BeRex E/B at 25°C, 50ohm system, Vdd=3.3V, Ids=45mA, Down converting

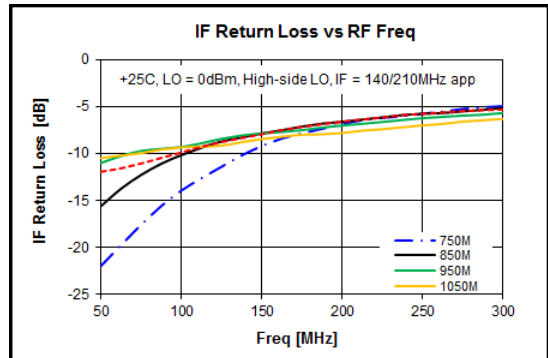
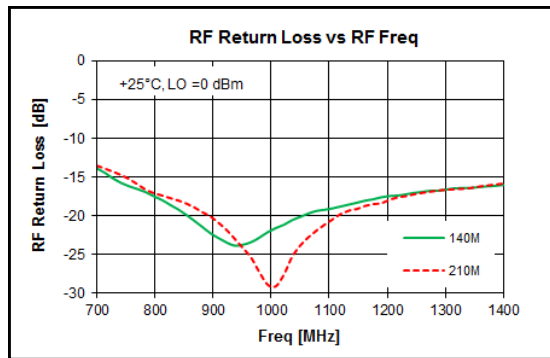
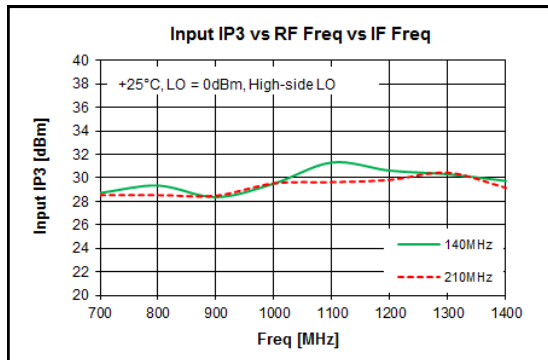
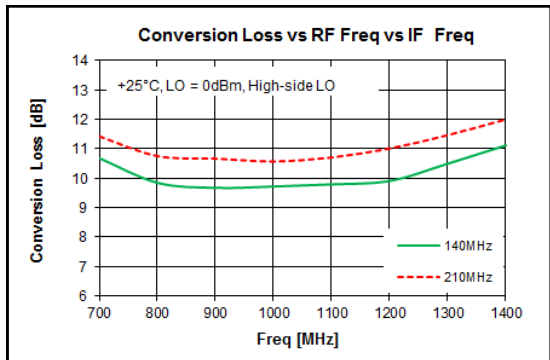
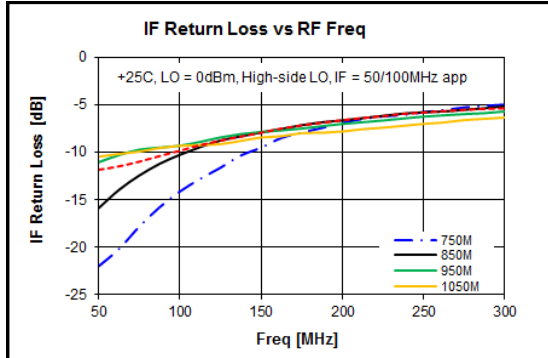
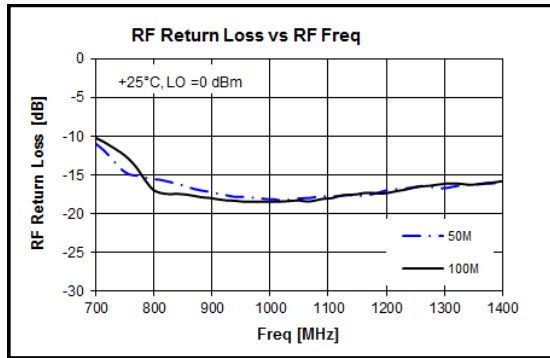
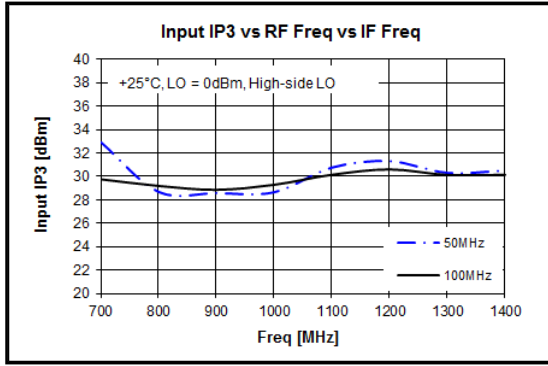
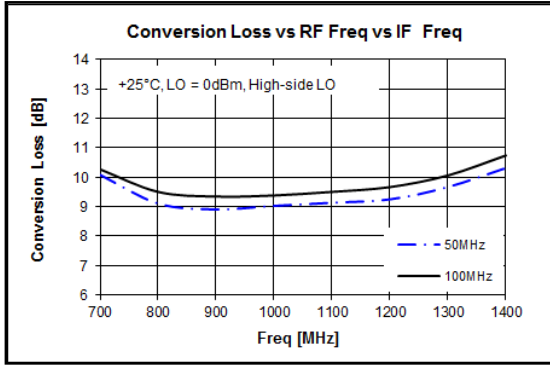

Preliminary Datasheet

BM831

Mixer

0.7~1.4GHz High IIP3 GaAs MMIC Mixer with Integrated LO AMP



Typical Test Data

Test condition _ Measured on BeRex E/B at 25°C, 50ohm system, Vdd=3.3V, Ids=45mA, Down converting

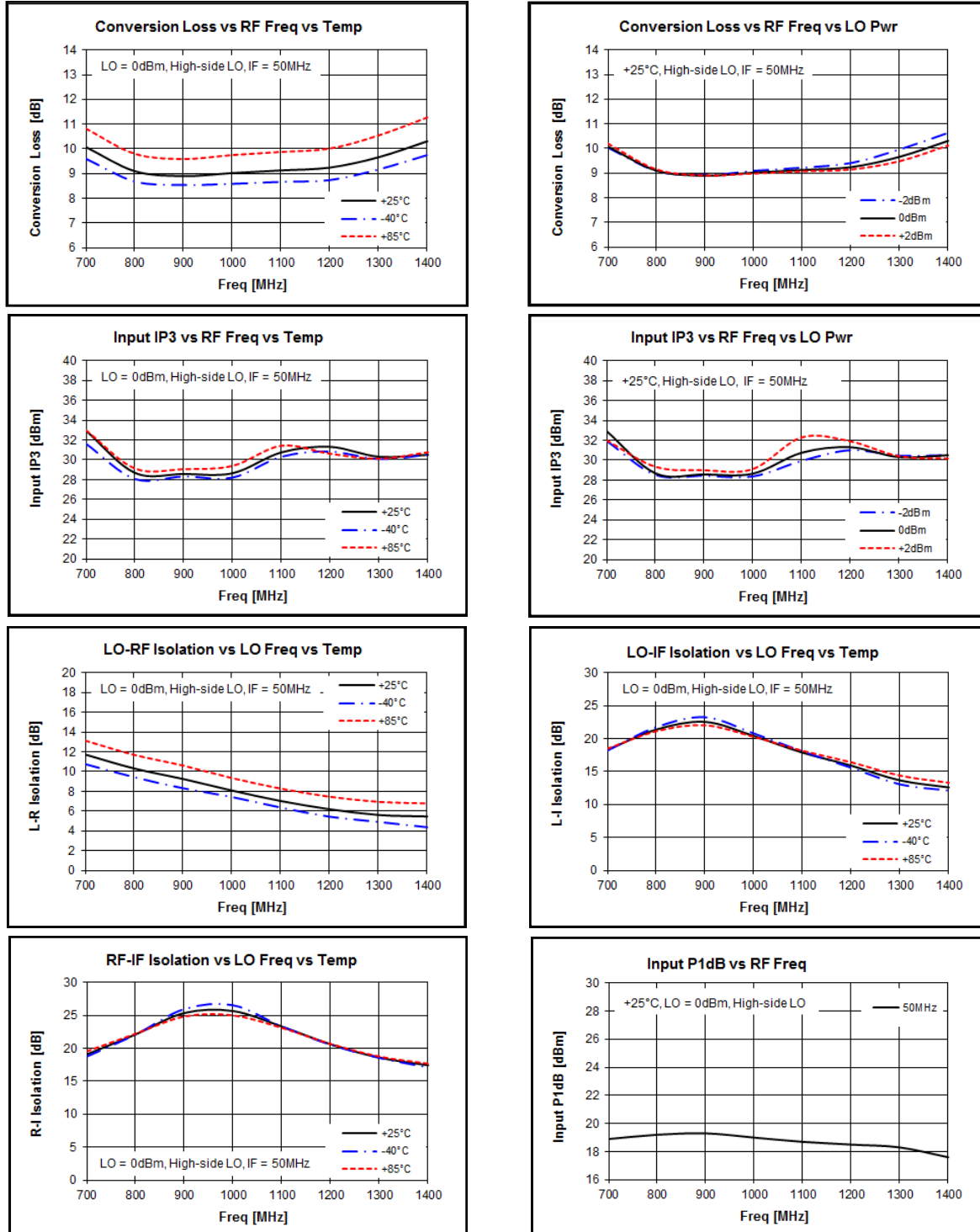

Preliminary Datasheet

BM831

Mixer

0.7~1.4GHz High IIP3 GaAs MMIC Mixer with Integrated LO AMP



Typical Test Data

Test condition _ Measured on BeRex E/B at 25°C, 50ohm system, Vdd=3.3V, Ids=45mA, Down converting

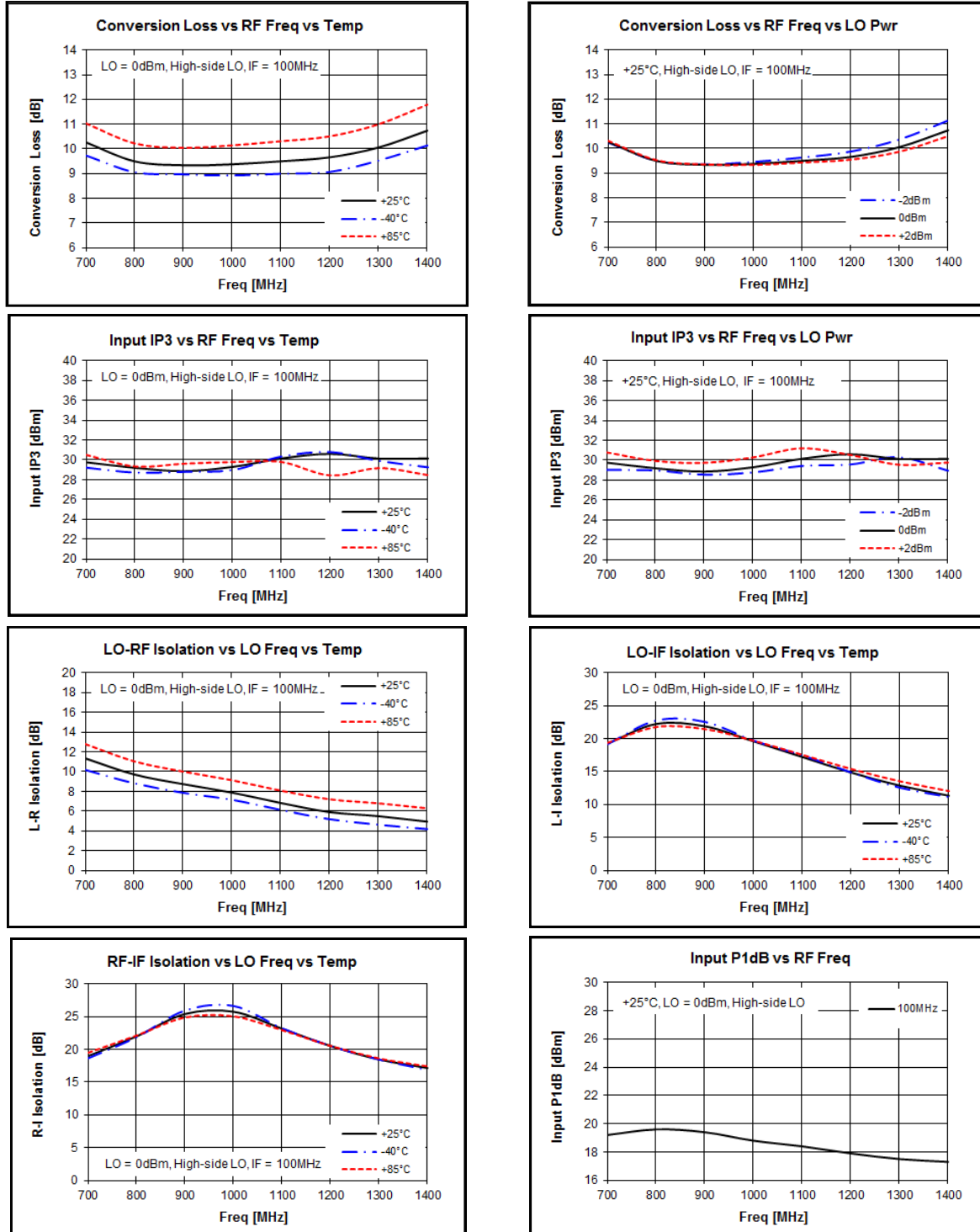

Preliminary Datasheet

BM831

Mixer

0.7~1.4GHz High IIP3 GaAs MMIC Mixer with Integrated LO AMP



Typical Test Data

Test condition _ Measured on BeRex E/B at 25°C, 50ohm system, Vdd=3.3V, Ids=45mA, Down converting

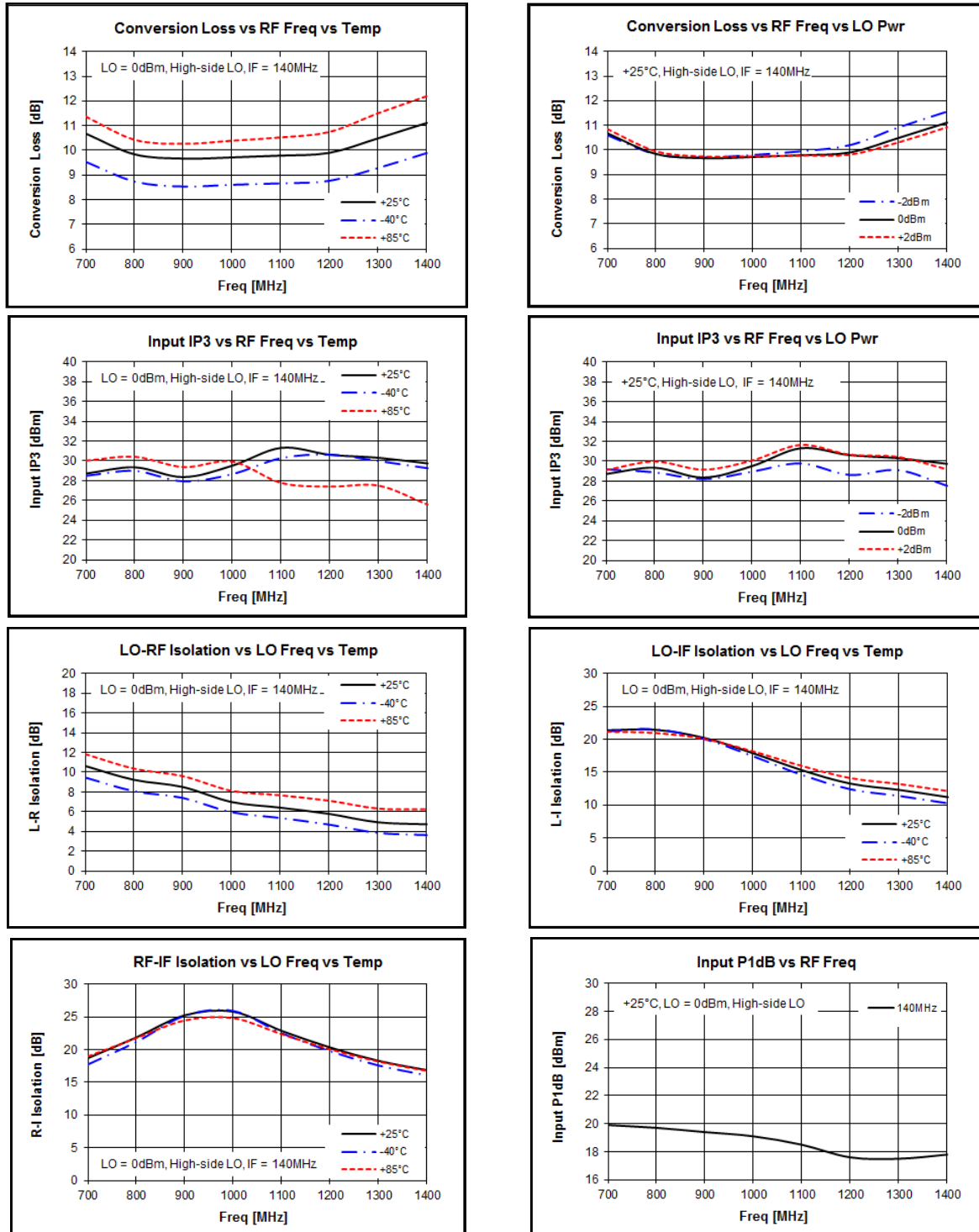

Preliminary Datasheet

BM831

Mixer

0.7~1.4GHz High IIP3 GaAs MMIC Mixer with Integrated LO AMP



Typical Test Data

Test condition _ Measured on BeRex E/B at 25°C, 50ohm system, Vdd=3.3V, Ids=45mA, Down converting

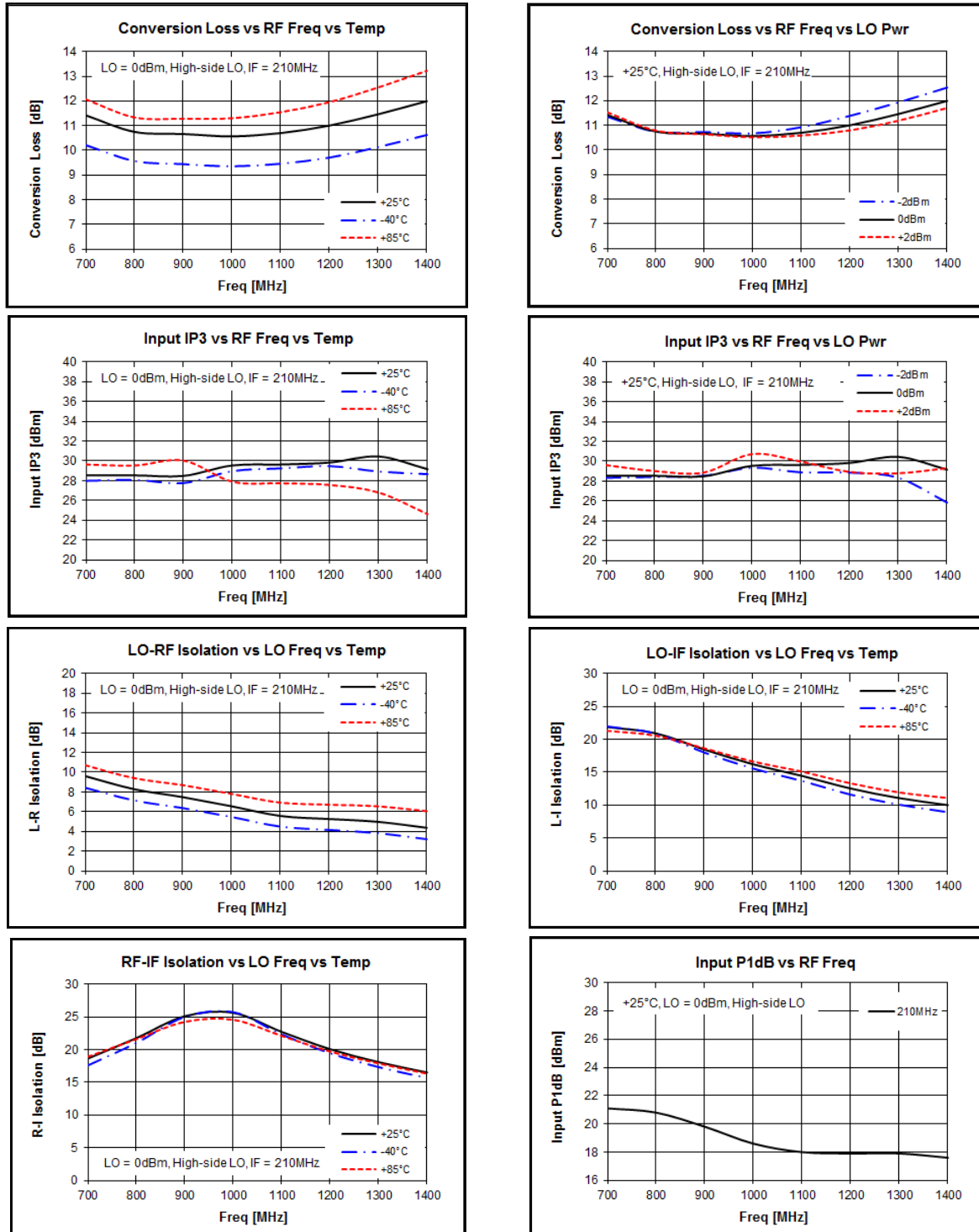

Preliminary Datasheet

BM831

Mixer

0.7~1.4GHz High IIP3 GaAs MMIC Mixer with Integrated LO AMP



Typical Test Data

Test condition _ Measured on BeRex E/B at 25°C, 50ohm system, Vdd=5V, Ids=58mA , Up converting

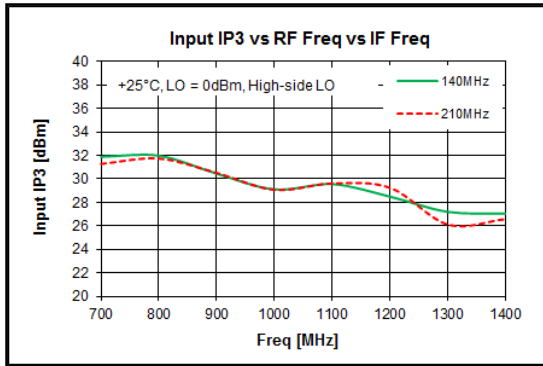
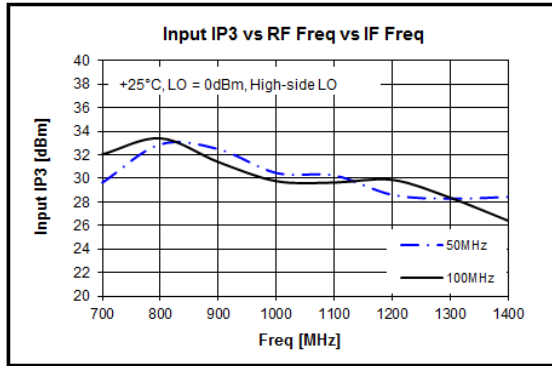

Test condition _ Measured on BeRex E/B at 25°C, 50ohm system, Vdd=3.3V, Ids=45mA, Up converting

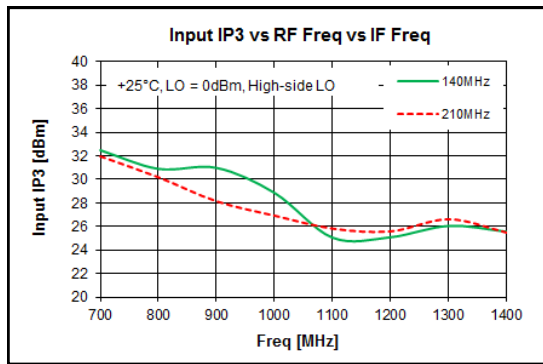
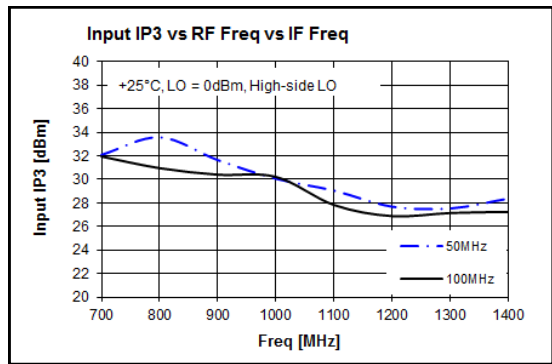

Spur Table

		M					
		0	1	2	3	4	5
N	0		8	5	6	0	1
	1	16	0	42	17	21	18
	2	51	61	46	61	50	49
	3	75	84	80	75	84	72
	4	98	98	108	98	102	105
	5	110	114	114	114	114	114

Spur table is $N \times f_{RF} - M \times f_{LO}$ mixer spurious products for 0 dBm input power, unless otherwise noted.

RF Frequency = 900 MHz

LO Frequency = 1041 MHz

All values in dBc relative to the IF Power Level.

BM831

Mixer

0.7~1.4GHz High IIP3 GaAs MMIC Mixer with Integrated LO AMP



Package Outline Drawing

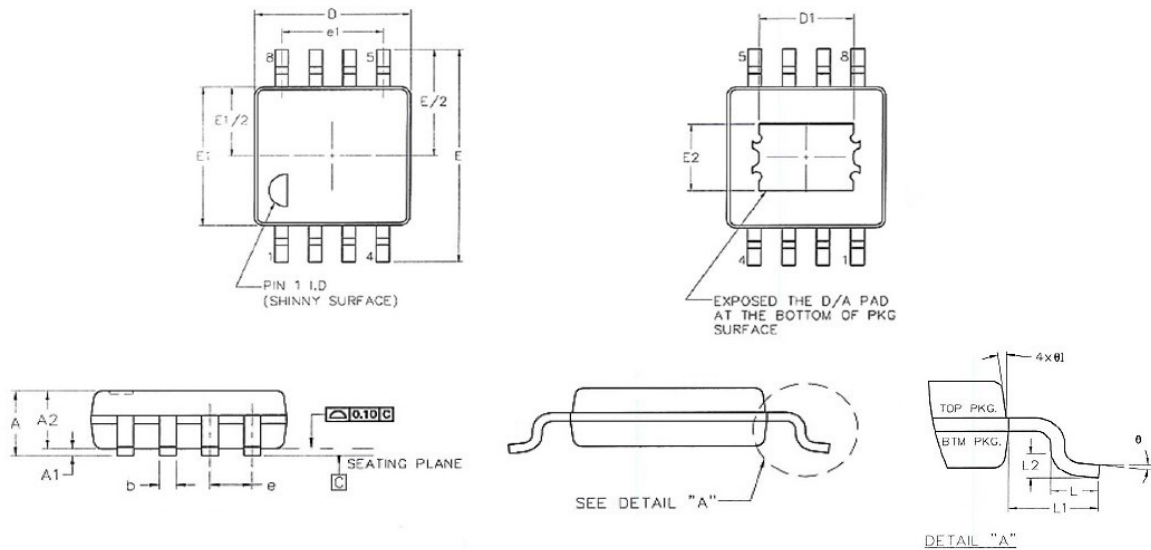

	A	A1	A2	b	D	D1	E	E1	E2	e	e1	L	L1	L2
Min		2	32	11	114	66	188	114	54	25.5 Typ	76.7 Typ	16	37 Ref	10 Typ
Nom		4	34		118		192	118				22		
Max	42	6	36	15	122	70	196	122	58			27		

*Remark all unit in mils

Package Marking

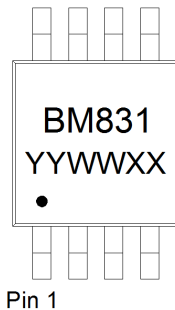

YY = Year, WW = Working Week,
XX = Wafer No.

Evaluation Board Drawing

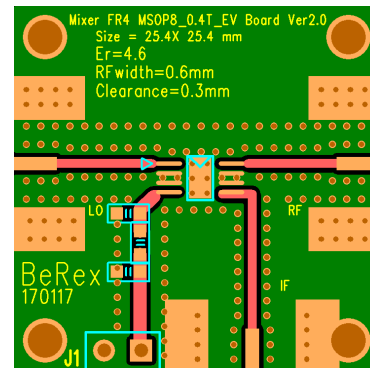

BM831

Mixer

0.7~1.4GHz High IIP3 GaAs MMIC Mixer with Integrated LO AMP



Suggested PCB Land Pattern and PAD Layout

PCB Land Pattern

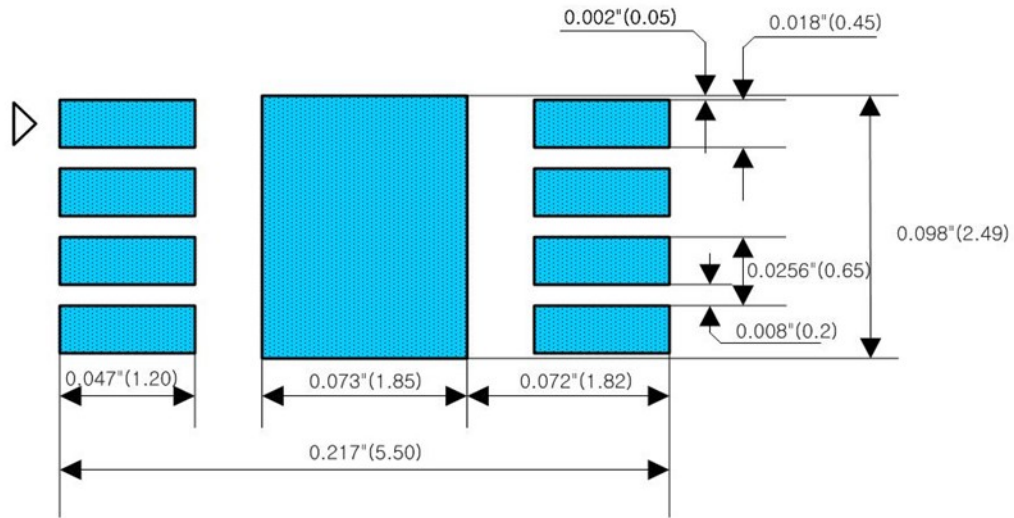

- Note :**
1. Connection to Bottom Ground with multiple via holes.
 2. Via holes _ as many as possible.
 3. All Dimensions _ millimeters.
 4. PCB lay out _ on BeRex website.
 5. Use 0.15T metal mask to avoid incomplete soldering on exposed ground pad.

Pin Configuration

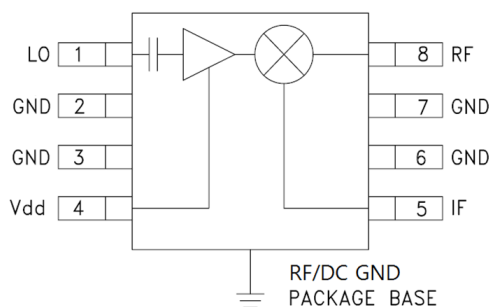

Pin No.	Label	Description
1	LO	Local Oscillator Injection. Internally DC Blocked
2,3,6,7	GND	RF/DC Ground.
4	Vdd	Power supply for LO amplifier
5	IF	Intermediate Frequency
8	RF	Radio Frequency
Backside Paddle	GND	RF/DC Ground. Follow recommended via pattern and ensure good solder attach for best thermal and electrical performance.

BM831

Mixer

0.7~1.4GHz High IIP3 GaAs MMIC Mixer with Integrated LO AMP



Preliminary Datasheet

Tape & Reel

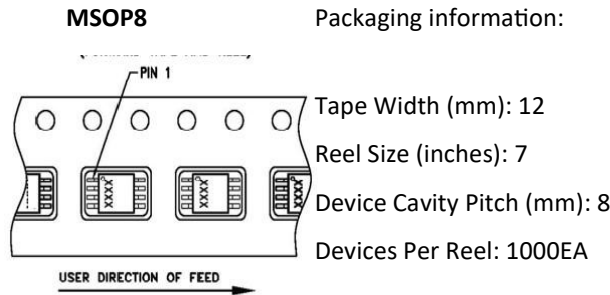

Lead plating finish

100% Tin Matte finish

(All BeRex products undergoes a 1 hour, 150 degree C, Anneal bake to eliminate thin whisker growth concerns.)

MSL / ESD Rating

ESD Rating:	Class 1B
Value:	Passes <1000V
Test:	Human Body Model (HBM)
Standard:	JEDEC Standard JESD22-A114B
MSL Rating:	Level 1 at +265°C convection reflow
Standard:	JEDEC Standard J-STD-020



Proper ESD procedures should be followed when handling this device.

NATO CAGE code:

2	N	9	6	F
---	---	---	---	---