

SRAM

128K X 8 HIGH SPEED CMOS STATIC RAM

FEATURES

- Fast Address Access Times : 10/12/15ns
- Single 3.3V $\pm 0.3V$ power supply
- Low Power Consumption : 110/105/100mA
- TTL I/O compatible
- 2.0V data retention mode
- Automatic power-down when deselected
- Available packages :
32-pin 300 mil DIP/SOJ & 32-pin SOP/TSOP-I
- Industry Standard Pin Assignment

PIN CONFIGURATION

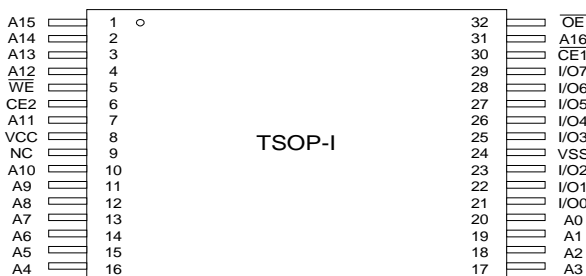
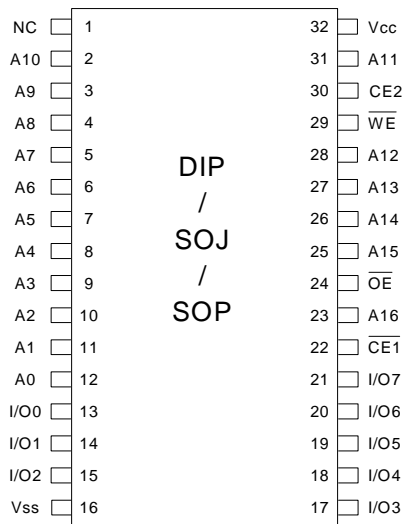

GENERAL DESCRIPTION

The T14L1024A is a one-megabit density, fast static random access memory organized as 131,072 words by 8 bits. It is designed for use in high performance memory applications such as main memory storage and high speed communication buffers. Fabricated using high performance CMOS technology, access times down to 10ns are achieved. Memory expansion by banking is easily accomplished using the chip enable pins $\overline{CE1}$ and $\overline{CE2}$. This device is packaged in a standard 32-pin 300 mil DIP/SOJ and 32-pin SOP/TSOP-I.

BLOCK DIAGRAM

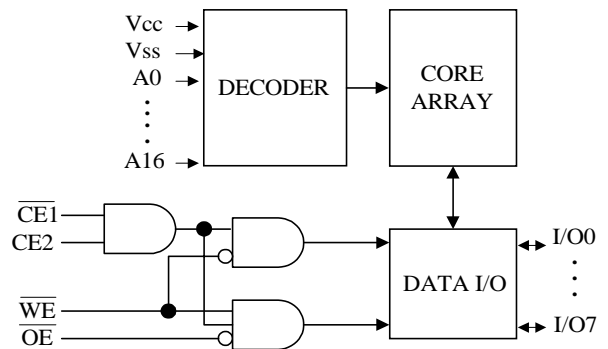

PIN DESCRIPTION

SYMBOL	DESCRIPTION
A0 - A16	Address Inputs
I/O0 - I/O7	Data Inputs/Outputs
$\overline{CE1}, \overline{CE2}$	Chip Select Inputs
\overline{WE}	Write Enable
\overline{OE}	Output Enable
Vcc	Power Supply
Vss	Ground

PART NUMBER EXAMPLES

	PACKAGE	SPEED
T14L1024A-10J	SOJ 300mil	10ns
T14L1024A-10P	TSOP-I 8x13.4mm	10ns
T14L1024A-10H	TSOP-I 8x20mm	10ns
T14L1024A-10N	DIP 300mil	10ns
T14L1024A-10D	SOP	10ns

DC CHARACTERISTICS ABSOLUTE MAXIMUM RATINGS

PARAMETER	SYM	RATING	UNIT
Power Supply Voltage	V _{CC}	-0.5 to 4.6	V
Input Voltage	V _{IN}	-0.5 to V _{CC} +0.5	V
Output Voltage	V _{OUT}	-0.5 to V _{CC} +0.5	V
Operating Temperature	T _{OPR}	0 to +70	°C
Storage Temperature	T _{STG}	-55 to +150	°C
Power Dissipation	P _D	1.0	W
Short Circuit Output Current	I _{OUT}	50	mA

TRUTH TABLE

CE1	CE2	OE	WE	MODE	I/O0- I/O7	V _{CC}
H	X	X	X	Not Selected	High-Z	I _{SB} , I _{SB1}
X	L	X	X	Not Selected	High-Z	I _{SB} , I _{SB1}
L	H	H	H	Output Disable	High-Z	I _{CC}
L	H	L	H	Read	Data Out	I _{CC}
L	H	X	L	Write	Data In	I _{CC}

OPERATING CHARACTERISTICS

 (V_{CC} = 3.3V ±0.3V, T_a = 0 to 70°C)

PARAMETER	SYM.	TEST CONDITIONS	MIN.	MAX.	UNIT	
Power Supply Voltage	V _{CC}		3.0	3.6	V	
Input Low Voltage	V _{IL}		-0.5	0.8	V	
Input High Voltage	V _{IH}		2.1	V _{CC} +0.3	V	
Input Leakage Current	I _{LI}	V _{IN} = V _{SS} to V _{CC}	-	5	uA	
Output Leakage Current	I _{LO}	V _{IN} = V _{SS} to V _{CC} , $\overline{CE1} = V_{IH}$ or CE2 = V _{IL} or $\overline{OE} = V_{IH}$ or $\overline{WE} = V_{IL}$	-	5	uA	
Output Low Voltage	V _{OL}	I _{OL} = 4.0 mA	-	0.4	V	
Output High Voltage	V _{OH}	I _{OH} = -2.0 mA	2.4	-	V	
Operating Power Supply Current	I _{CC}	$\overline{CE1} = V_{IL}$ CE2 = V _{IH} ; f = max IO = 0mA	10ns	-	110	mA
			12ns	-	105	mA
			15ns	-	100	mA
Standby Power Supply Current	I _{SB}	$\overline{CE1} = V_{IH}$, CE2 = V _{IL} , IO = 0mA	-	25	mA	
	I _{SB1}	V _{CC} = max; $\overline{CE1} > V_{CC}-0.2V$ or CE2 < V _{SS} +0.2V; f=0mhz; IO = 0mA	-	5	mA	

Note: Typical characteristics are at V_{CC} = 3.3V, T_a = 25°C

RECOMMENDED OPERATING CONDITIONS

PARAMETER	SYM	MIN	TYP	MAX	UNIT
Supply Voltage	V _{CC}	Typ-0.3	3.3	Typ+0.3	V
Input Voltage, low	V _{IL}	-0.3	-	0.8	V
Input Voltage, high	V _{IH}	2.1	-	V _{CC} +0.3	V
Ambient Temperature	T _A	0	-	70	°C

CAPACITANCE

PARAMETER	SYMBOL	CONDITION	MAX.	UNIT
Input Capacitance	C _{IN}	V _{IN} = 0V	6	pF
Input/ Output Capacitance	C _{I/O}	V _{OUT} = 0V	8	pF

Note: These parameters are sampled but not 100% tested.

AC TEST CONDITIONS

PARAMETER	CONDITIONS
Input Pulse Levels	0V to 3V
Input Rise and Fall Times	3.0 ns
Input and Output Timing Reference Level	1.5V
Output Load	C _L =30pF, I _{OH} /I _{OL} = -2mA/4mA

AC TEST LOADS AND WAVEFORM

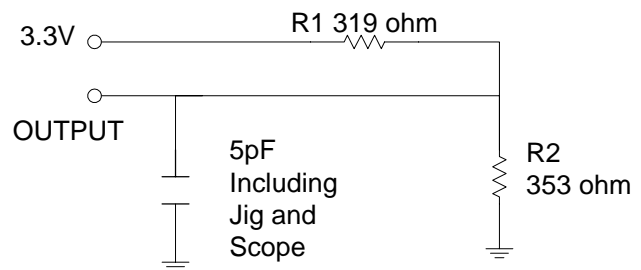
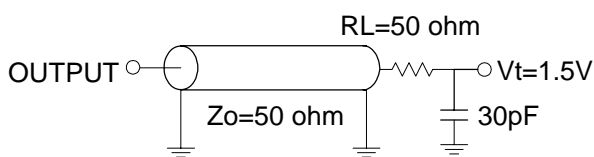

(For TCLZ, TOLZ, TCHZ, TOHZ, TWHZ, TOW)

AC CHARACTERISTICS

 ($V_{CC}=3.3V \pm 0.3V$, $V_{SS} = 0V$, $T_a = 0$ to $70^{\circ}C$)

(1) READ CYCLE

PARAMETER	SYM.	T14L1024A-10		T14L1024A-12		T14L1024A-15		UNIT
		MIN.	MAX.	MIN.	MAX.	MIN.	MAX.	
Read Cycle Time	t_{RC}	10	-	12	-	15	-	ns
Address Access Time	t_{AA}	-	10	-	12	-	15	ns
Chip Enable Access Time	t_{ACS}	-	10	-	12	-	15	ns
Output Enable to Output Valid	t_{AOE}	-	6	-	7	-	7	ns
Chip Enable to Output in Low Z	t_{CLZ}^*	3	-	3	-	3	-	ns
Output Enable to Output in Low Z	t_{OLZ}^*	0	-	0	-	0	-	ns
Chip Disable to Output in High Z	t_{CHZ}^*	-	5	-	6	-	7	ns
Output Disable to Output in High Z	t_{OHZ}^*	-	5	-	6	-	7	ns
Output Hold from Address Change	t_{OH}	3	-	3	-	3	-	ns

* These parameters are sampled but not 100% tested.

(2)WRITE CYCLE

PARAMETER	SYM.	T14L1024A-10		T14L1024A-12		T14L1024A-15		UNIT
		MIN.	MAX.	MIN.	MAX.	MIN.	MAX.	
Write Cycle Time	t_{WC}	10	-	12	-	15	-	ns
Chip Enable to End of Write	t_{CW}	8	-	10	-	11	-	ns
Address Valid to End of Write	t_{AW}	8	-	10	-	11	-	ns
Address Setup Time	t_{AS}	0	-	0	-	0	-	ns
Write Pulse Width	t_{WP}	8	-	10	-	11	-	ns
Write Recovery Time	t_{WR}	0	-	0	-	0	-	ns
Data Valid to End of Write	t_{DW}	6	-	8	-	8	-	ns
Data Hold from End of Write	t_{DH}	0	-	0	-	0	-	ns
Write to Output in High Z	t_{WHZ}^*	-	5	-	6	-	6	ns
Output Disable to Output in High Z	t_{OHZ}^*	-	5	-	6	-	7	ns
Output Active from End of Write	t_{OW}	0	-	0	-	0	-	ns

* These parameters are sampled but not 100% tested.

TIMING WAVEFORMS

READ CYCLE 1

(Address Controlled)

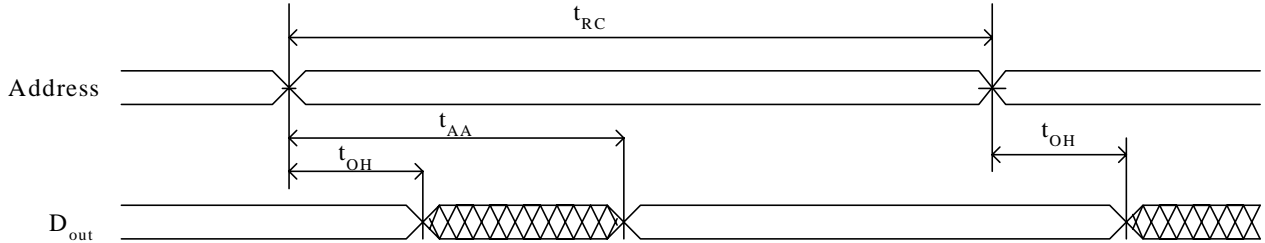

READ CYCLE 2

(Chip Enable Controlled)

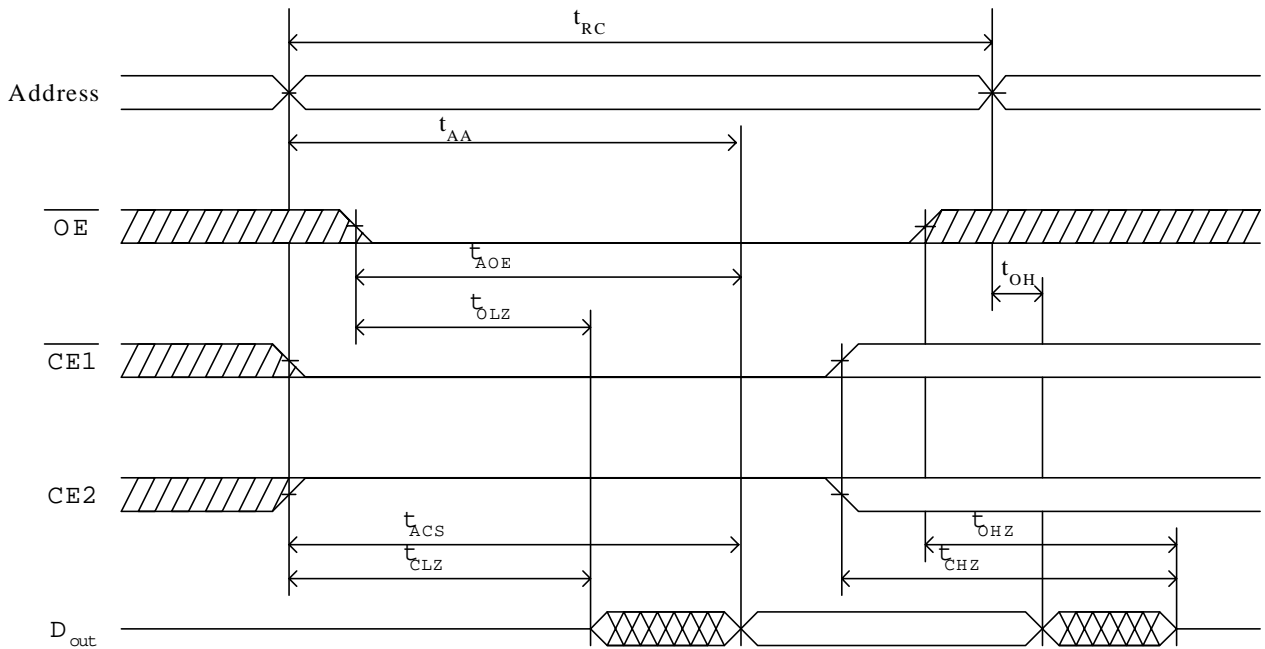

 DON'T CARE

 UNDEFINED

WRITE CYCLE 1 (\overline{OE} CLOCK)

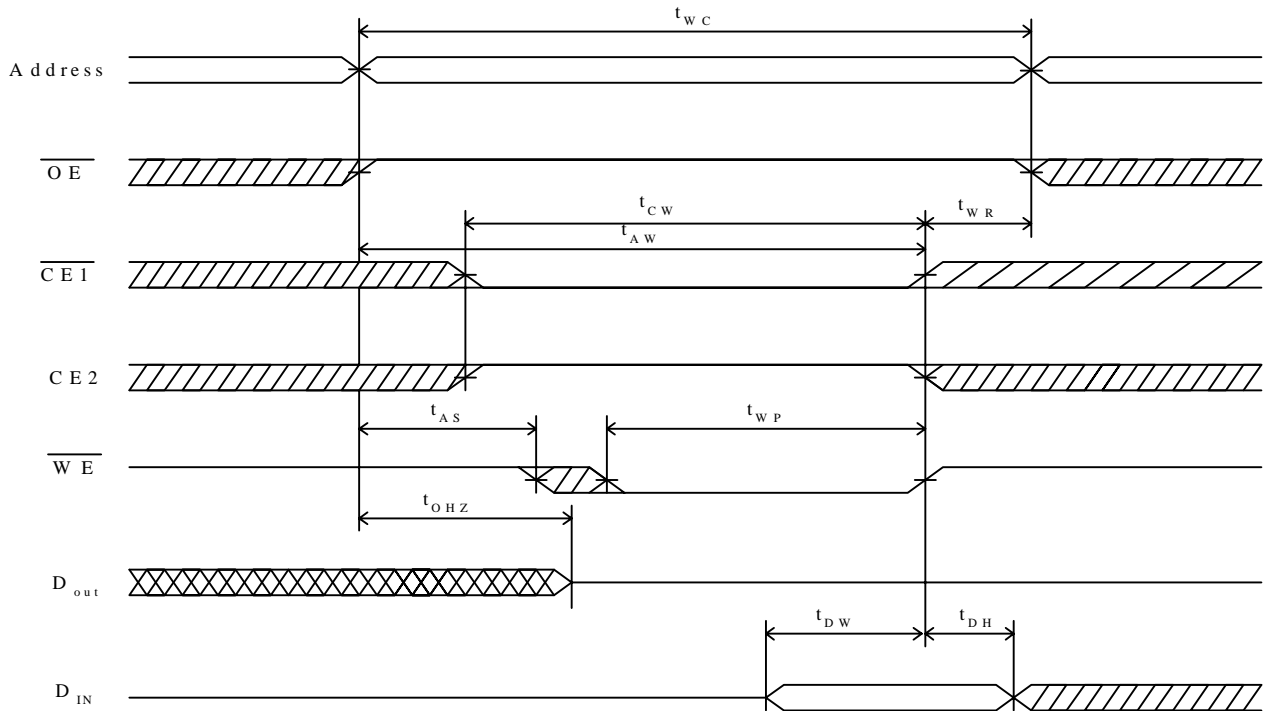

WRITE CYCLE 2 ($\overline{OE} = V_{IL}$ Fixed)

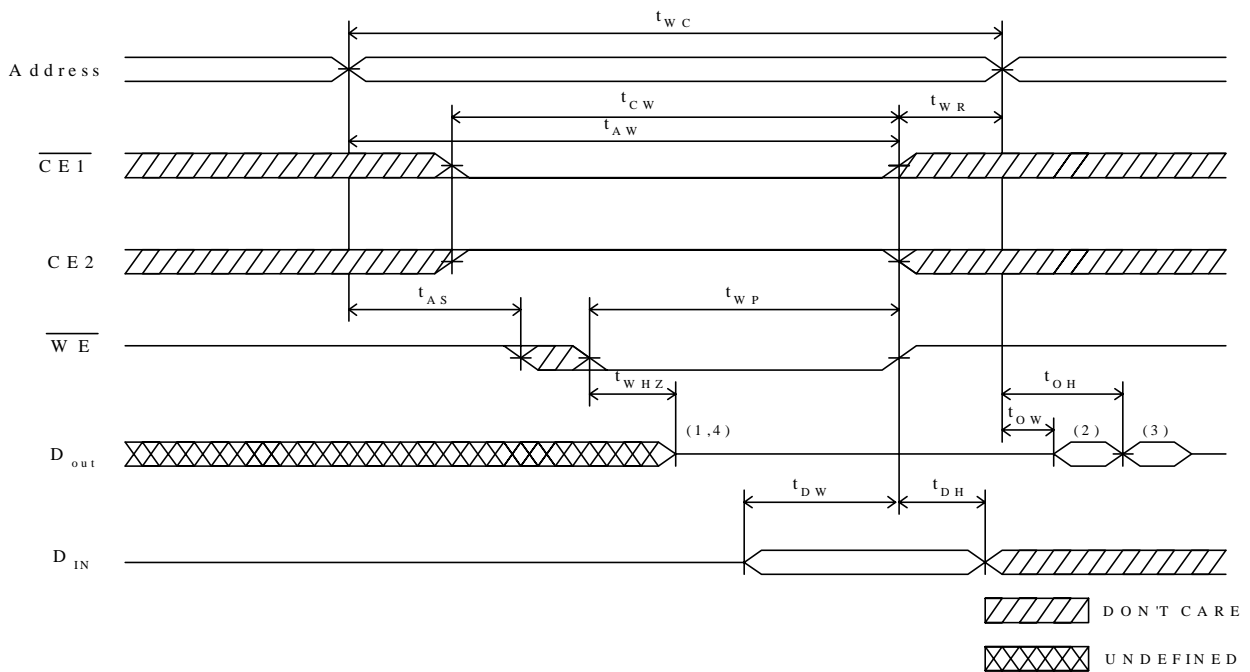

- Notes:
1. During this period, I/O pins are in the output state, so input signals of opposite phase to the outputs should not be applied.
 2. The data output from D_{OUT} are the same as the data written to D_{IN} during the write cycle.
 3. D_{OUT} provides the read data for the next address.
 4. Transition is measured ± 500 mV from steady state with $C_L = 5$ pF. This parameter is guaranteed but not 100% tested.
 5. If \overline{OE} is low during a \overline{WE} controlled write cycle, the write pulse width must be the larger of t_{WP} or $(t_{WHZ} + t_{DW})$ to allow the I/O drivers to turn off and data to be placed on the bus for the required t_{DW} . If \overline{OE} is high during a \overline{WE} controlled write cycle, this requirement does not apply and the write pulse can be as short as the specified t_{WP} .

PACKAGE DIMENSIONS

32-LEAD SOJ (300 mil)

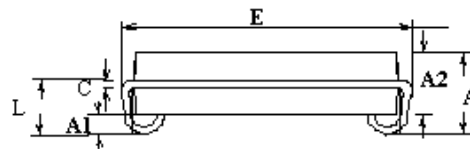
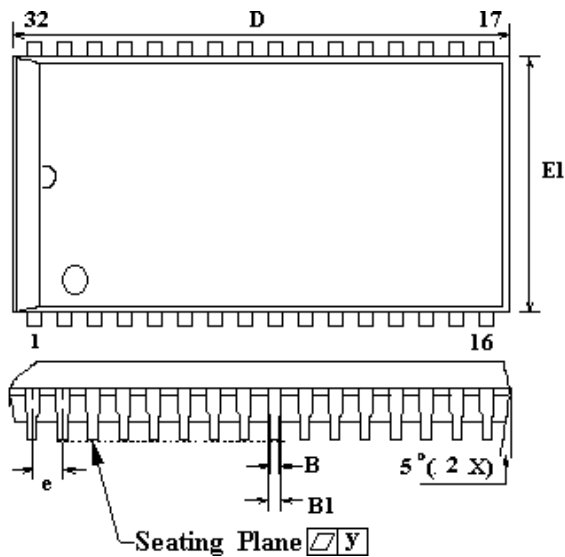

SYMBOL	DIMENSIONS IN INCHES	DIMENSIONS IN MM
A	0.140(MAX)	3.556(MAX)
A1	0.026(MIN)	0.660(MIN)
A2	0.100±0.005	2.540±0.127
B	0.018(TYP)	0.457(TYP)
B1	0.028(TYP)	0.711(TYP)
C	0.008(TYP)	0.203(TYP)
D	0.823±0.005	20.904±0.127
E	0.335±0.010	8.509±0.254
E1	0.300±0.005	7.620±0.127
e	0.050(TYP)	1.270(TYP)
L	0.086±0.010	2.184±0.254
y	0.003(MAX)	0.076(MAX)

PACKAGE DIMENSIONS
32-LEAD TSOP-I (8x20mm)

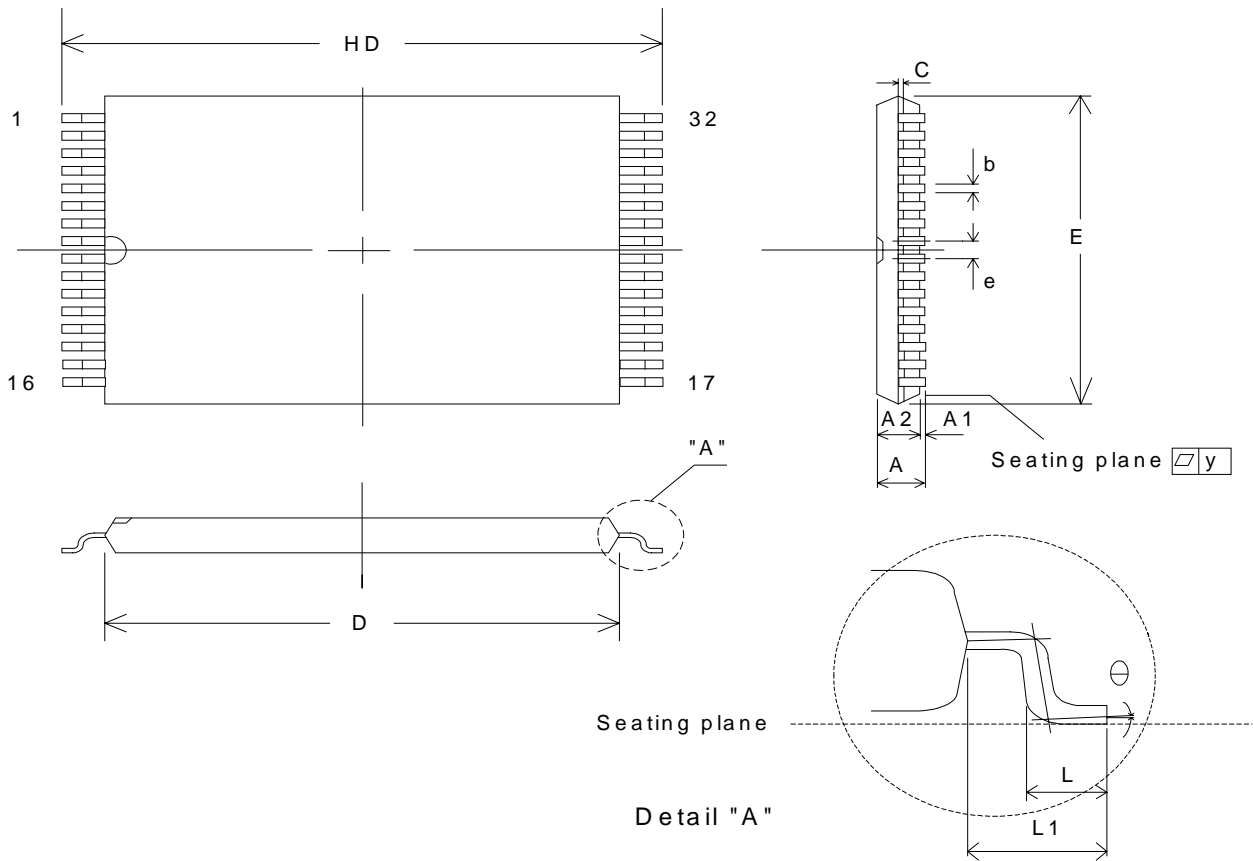

SYMBOL	DIMENSIONS IN INCHES			DIMENSIONS IN MM		
	MIN	NOM	MAX	MIN	NOM	MAX
A	-	-	0.047	-	-	1.20
A1	0.002	-	0.006	0.05	-	0.15
A2	0.035	0.040	0.041	0.90	1.00	1.05
b	0.007	0.008	0.011	0.17	0.20	0.27
C	0.004	0.006	0.008	0.10	0.15	0.21
HD	0.787 TYP			20.00 TYP		
D	0.724 TYP			18.40 TYP		
E	0.315 TYP			8.00 TYP		
e	0.020 TYP			0.50 TYP		
L	0.020	0.024	0.028	0.50	0.60	0.70
L1	0.032 TYP			0.813 TYP		
θ	0°	3°	5°	0°	3°	5°

PACKAGE DIMENSIONS

32-LEAD TSOP-I (8x13.4mm)

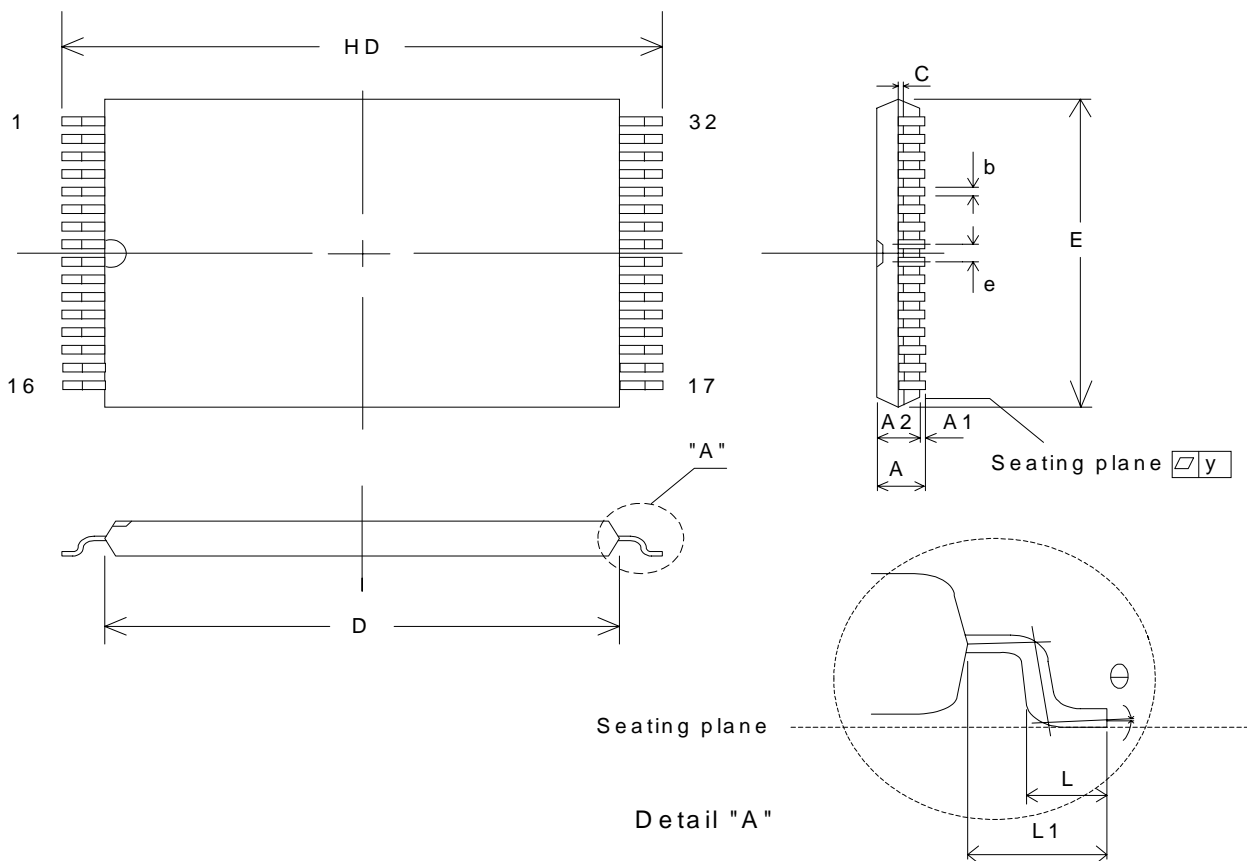

SYMBOL	DIMENSIONS IN INCHES			DIMENSIONS IN MM		
	MIN	NOM	MAX	MIN	NOM	MAX
A	-	-	0.047	-	-	1.20
A1	0.002	-	0.006	0.05	-	0.15
A2	0.035	0.040	0.041	0.90	1.00	1.05
b	0.007	0.008	0.011	0.17	0.20	0.27
C	0.004	0.006	0.008	0.10	0.15	0.21
HD	0.528 TYP			13.40 TYP		
D	0.465 TYP			11.80 TYP		
E	0.315 TYP			8.00 TYP		
e	0.020 TYP			0.50 TYP		
L	0.020	0.024	0.028	0.50	0.60	0.7
L1	0.032 TYP			0.813 TYP		
θ	0°	3°	5°	0°	3°	5°

PACKAGE DIMENSIONS

32-LEAD DIP (300 mil)

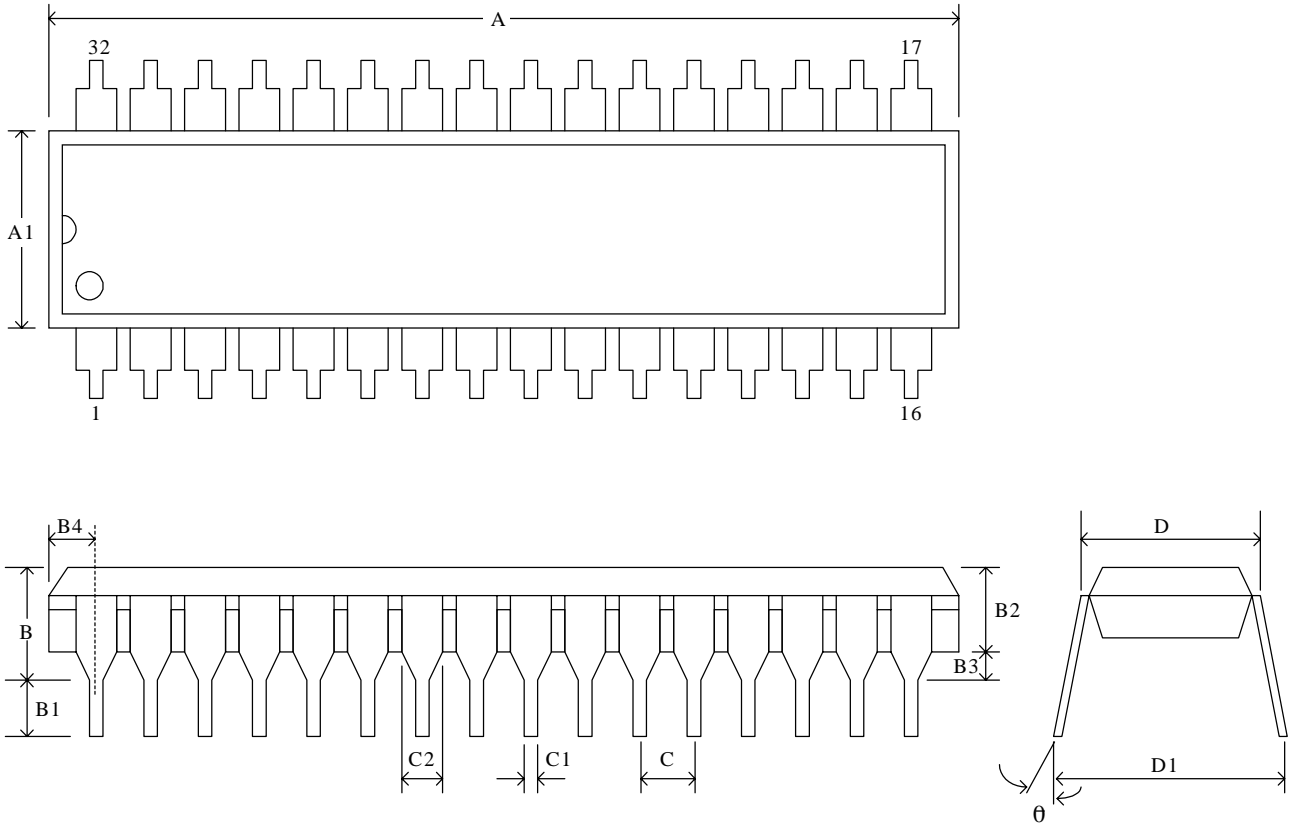

Symbol	Dimension in mm			Dimension in inch		
	Min	Nom	Max	Min	Nom	Max
A	-	40.64	41.15	-	1.60	1.62
A1	7.26	7.36	7.46	0.286	0.290	0.294
B	-	-	5.08	-	-	0.200
B1	3.05	3.30	3.56	0.120	0.130	0.140
B2	3.68	3.81	3.94	0.145	0.150	0.155
B3	0.38	-	-	0.015	-	-
B4	-	-	1.65	-	-	0.065
C	2.29	2.54	2.79	0.090	0.100	0.110
C1	0.41	0.46	0.56	0.016	0.018	0.022
C2	1.47	1.52	1.63	0.58	0.60	0.64
D	7.49	8.00	8.50	0.295	0.315	0.335
D1	10.92	11.43	11.94	0.430	0.450	0.470
θ	0°	-	15°	0°	-	15°

PACKAGE DIMENSIONS

32-LEAD SOP

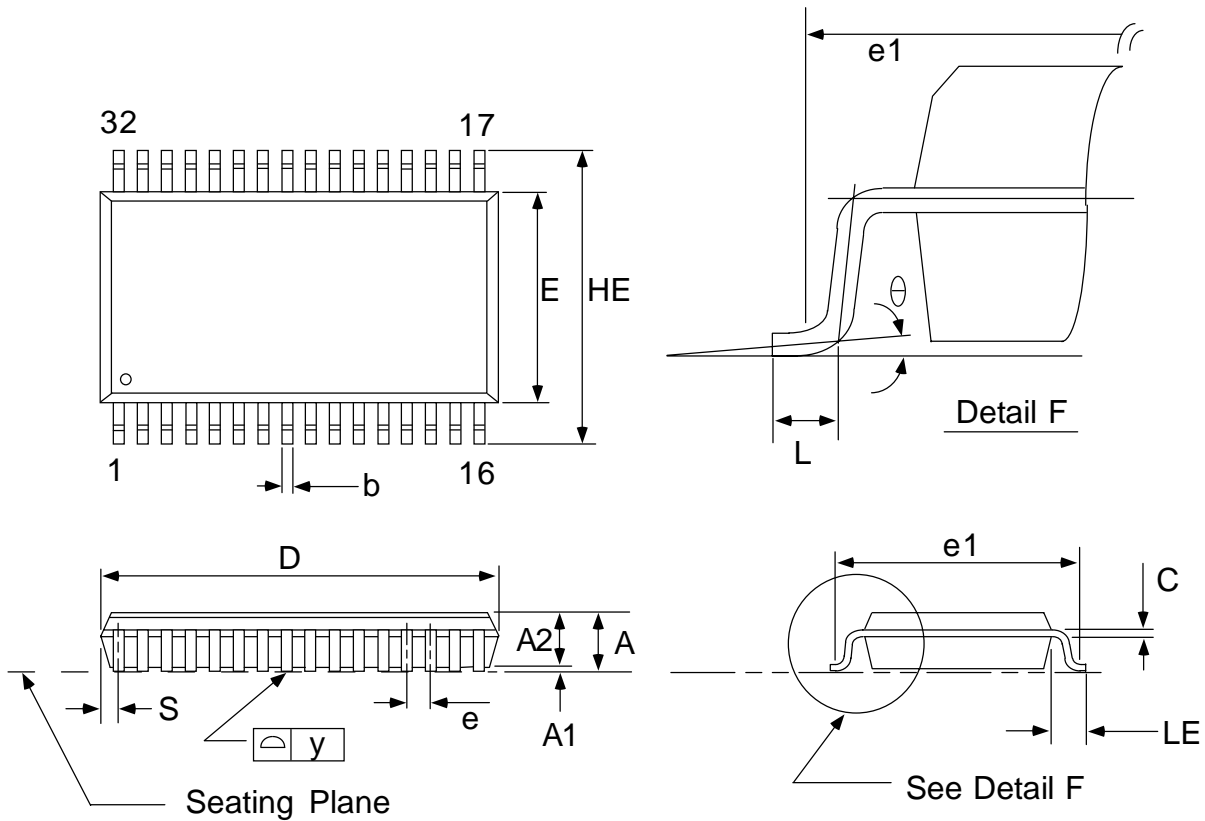

Symbol	Dimension in inches			Dimension in mm		
	min.	typ.	max	min.	typ.	max.
A	-	-	0.118	-	-	3.00
A1	0.004	-	-	0.10	-	-
A2	0.101	0.106	0.111	2.57	2.69	2.82
b	0.014	0.016	0.020	0.36	0.41	0.51
C	0.006	0.008	0.012	0.15	0.20	0.31
D	-	0.805	0.817	-	20.45	20.75
E	0.440	0.445	0.450	11.18	11.30	11.43
e	0.044	0.050	0.056	1.12	1.27	1.42
HE	0.546	0.556	0.556	13.87	14.12	14.38
L	0.023	0.031	0.039	0.58	0.79	0.99
LE	0.047	0.055	0.063	1.19	1.40	1.60
S	-	-	0.036	-	-	0.91
y	-	-	0.004	-	-	0.10
•	0°	-	10°	0°	-	10°

Notes :

1. Dimensions D max. & S include mold flash or tie bar burrs.
2. Dimension b does not include dambar protrusion / intrusion.
3. Dimensions D & E include mold mismatch and determined at the mold parting line.
4. controlling dimension : inches
5. general appearance spec should be based on final visual inspection spec.