

Transistors

2SA1625

HIGH VOLTAGE SWITCH

- High Breakdown Voltage
- High Speed Switching

ABSOLUTE MAXIMUM RATINGS (Ta=25°C)

Characteristics	Symbol	Rating	Unit
Collector Base Voltage	V _{CB0}	-400	V
Collector Emitter Voltage	V _{CEO}	-400	V
Emitter Base Voltage	V _{EB0}	-7	V
Base Current	I _B	-0.25	A
Collector Current (DC)	I _C	-0.5	A
Collector Current (Pulse)	I _C	-1.0	A
Collector Dissipation (Ta=25°C)	P _C	0.75	W
Collector Dissipation (Tc=25°C)	P _C	2	W
Junction Temperature	T _J	150	°C
Storage Temperature	T _{stg}	-55~150	°C

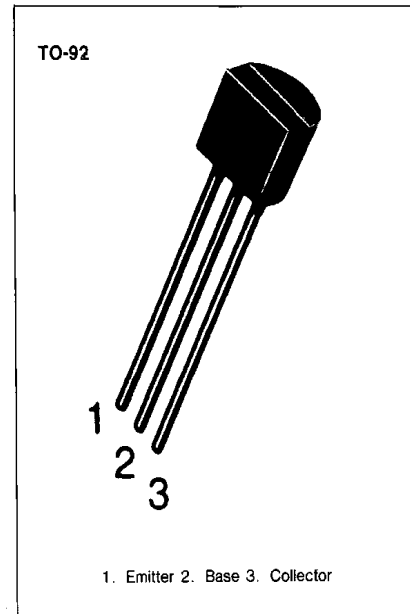

ELECTRICAL CHARACTERISTICS (Ta=25°C)

Characteristics	Symbol	Test Conditions	Min	Max	Unit
Collector Emitter Breakdown Voltage	BV _{CEO}	I _C = -1mA, I _B = 0	-400		V
Collector Cutoff Current	I _{CB0}	V _{CB} = -400V, I _E = 0		-1	μA
Emitter Cutoff Current	I _{EB0}	V _{EB} = -5V, I _C = 0		-1	μA
DC Current Gain	h _{FE}	V _{CE} = -5V, I _C = -50mA	40	200	
Collector Emitter Saturation Voltage	V _{CE(sat)}	I _C = -100mA, I _B = -10mA		-1	V
Base Emitter Saturation Voltage	V _{BE(sat)}	I _C = -100mA, I _B = -10mA		-1.2	V
Current Gain Bandwidth Product	f _T	V _{CE} = -10V, I _E = -10mA	10		MHz
Output Capacitance	C _{OB}	V _{CB} = -10V, f = 1MHz		25	pF
Turn On Time	t _{ON}	I _C = -100mA, R _L = 1.5kΩ		1	us
Storage Time	t _{STG}	I _{B1} = -10mA, I _{B2} = -10mA		5	us
Fall Time	t _F	V _{CC} = -150V		1	us

hFE CLASSIFICATION

Classification	M	L	K
hFE	40-80	60-120	100-200



STATIC CHARACTERISTIC

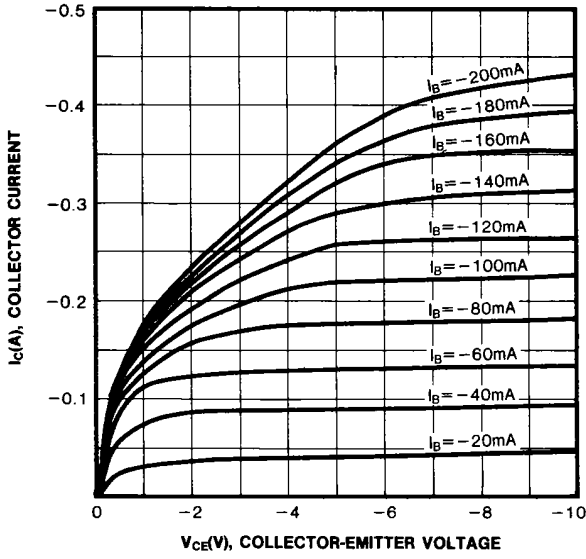

DC CURRENT GAIN

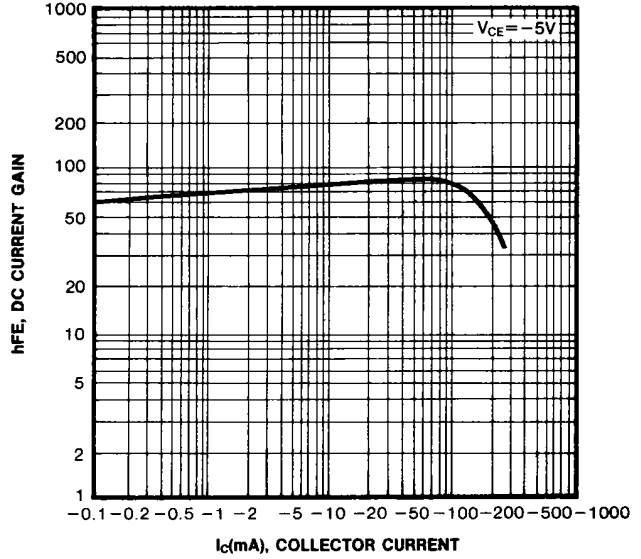

**COLLECTOR-EMITTER SATURATION VOLTAGE
BASE-EMITTER SATURATION VOLTAGE**

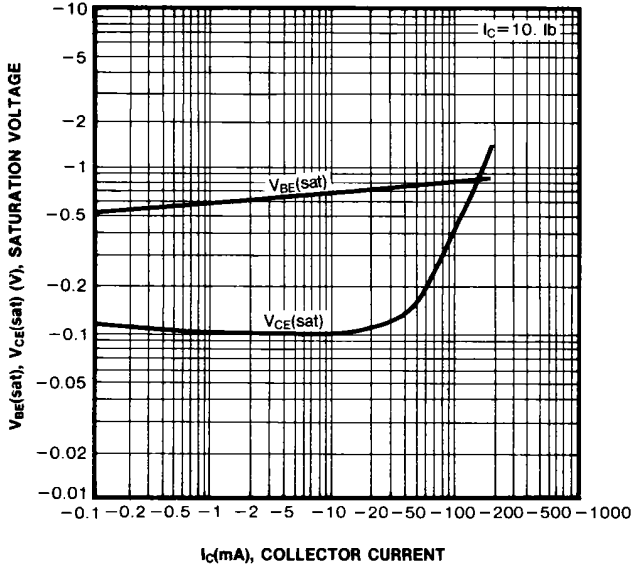

CURRENT GAIN BANDWIDTH PRODUCT

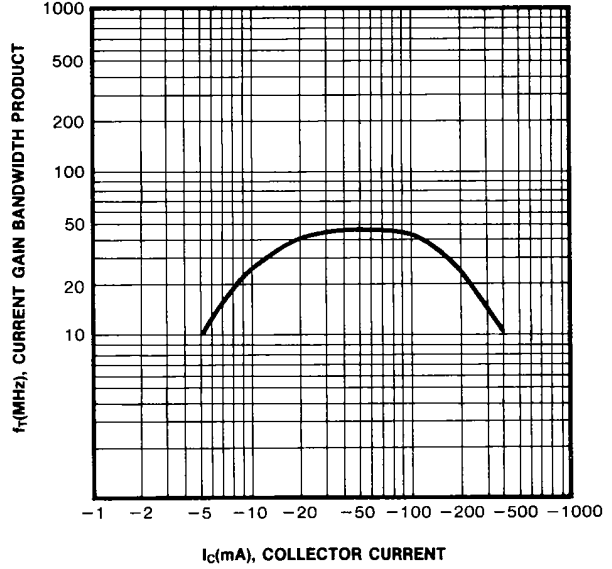

COLLECTOR OUTPUT CAPACITANCE

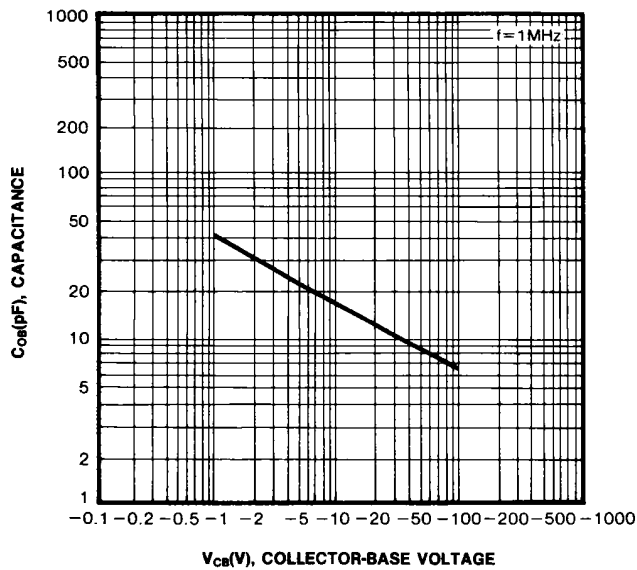

POWER DERATING

