

isc P-Channel MOSFET Transistor

IRF4905

FEATURES

- Advanced Process Technology
- Ultra Low On-Resistance
- Dynamic dv/dt Rating
- 175°C Operating Temperature
- Fast Switching
- P-Channel
- Fully Avalanche Rated

DESCRIPTION

- This benefit, combined with the fast switching speed and ruggedized device .

ABSOLUTE MAXIMUM RATINGS(T_a=25°C)

SYMBOL	PARAMETER	VALUE	UNIT
V _{DSS}	Drain-Source Voltage	-55	V
V _{GS}	Gate-Source Voltage-Continuous	±20	V
I _D	Drain Current-Continuous	-74	A
I _{DM}	Drain Current-Single Pluse	-260	A
P _D	Total Dissipation @T _C =25°C	200	W
T _J	Max. Operating Junction Temperature	-55~175	°C
T _{stg}	Storage Temperature	-55~175	°C

THERMAL CHARACTERISTICS

SYMBOL	PARAMETER	MAX	UNIT
R _{th j-c}	Thermal Resistance, Junction to Case	0.75	°C/W
R _{th j-a}	Thermal Resistance, Junction to Ambient	62	°C/W

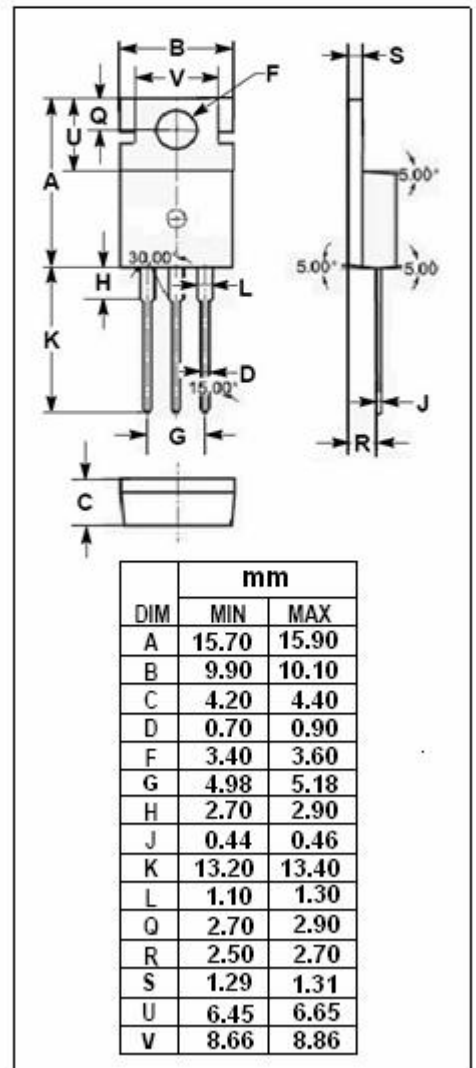
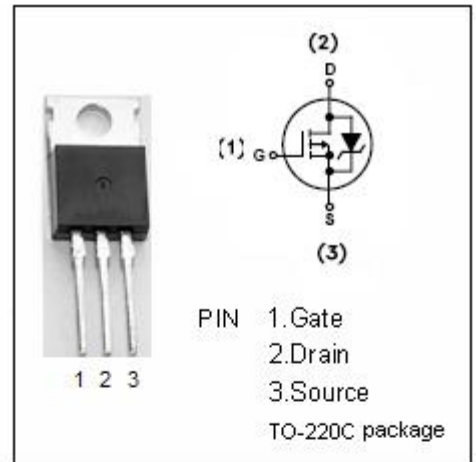

isc P-Channel MOSFET Transistor**IRF4905****ELECTRICAL CHARACTERISTICS** $T_C=25^{\circ}\text{C}$ unless otherwise specified

SYMBOL	PARAMETER	CONDITIONS	MIN	MAX	UNIT
$V_{(BR)DSS}$	Drain-Source Breakdown Voltage	$V_{GS}= 0; I_D= -0.25\text{mA}$	-55		V
$V_{GS(th)}$	Gate Threshold Voltage	$V_{DS}= V_{GS}; I_D=-0.25\text{mA}$	-2	-4	V
$R_{DS(on)}$	Drain-Source On-Resistance	$V_{GS}= -10\text{V}; I_D= -38\text{A}$		0.02	Ω
I_{GSS}	Gate-Body Leakage Current	$V_{GS}= \pm 20\text{V}; V_{DS}= 0$		± 100	nA
I_{DSS}	Zero Gate Voltage Drain Current	$V_{DS}= -55\text{V}; V_{GS}= 0$ $V_{DS}= -44\text{V}; V_{GS}= 0; T_J= 125^{\circ}\text{C}$		-25 -250	μA
V_{SD}	Forward On-Voltage	$I_S= -38\text{A}; V_{GS}= 0$		-1.6	V