

## CMOS 8-Bit Buffered Multiplying DACs

### General Description

The MX7524 and MAX7624 are CMOS 8-bit digital-to-analog converters (DAC) which will interface directly with most microprocessors. On-chip input latches make the DAC interface similar to a RAM write cycle where CS and WR are the only control inputs required.

Linearity up to  $\pm\frac{1}{2}$  LSB is available (MX7524L/C/U grades) and power consumption is less than 10mW. Monotonicity is guaranteed over the full temperature range.

For the MX7524, +5V TTL and CMOS logic compatibility is guaranteed when using +5V power. Over the supply range of +5V to +15V, all logic inputs are high voltage CMOS compatible.

The MAX7624 has +5V TTL/CMOS compatible inputs for a +12V to +15V supply range.

### Applications

- μP Controlled Gain
- Function Generators
- Bus Structured Instruments
- Automatic Test Equipment
- Digital Control Systems

### Typical Operating Circuit

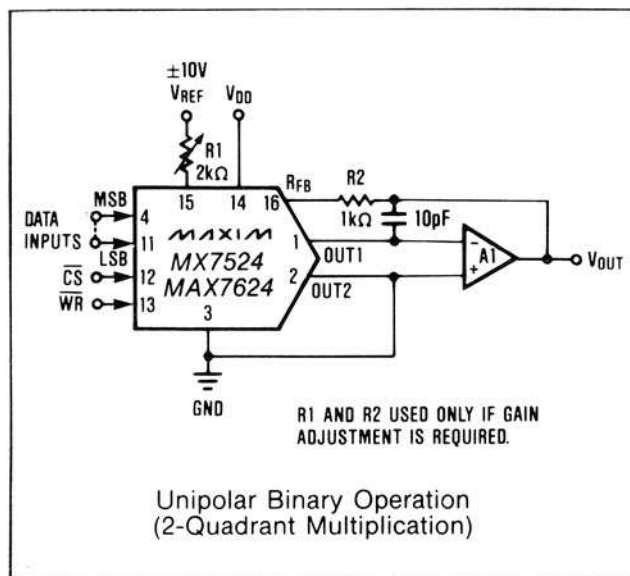

### Features

- ◆ Microprocessor Compatible
- ◆ On-Chip Data Latches
- ◆ Guaranteed Monotonic Over Temp.
- ◆ Low Power Consumption
- ◆ 8, 9, and 10-Bit Linearity
- ◆ MX7524 TTL/CMOS Compatible at +5V
- ◆ MAX7624 TTL/CMOS Compatible at +12V to +15V

### Ordering Information

PART	TEMP. RANGE	PACKAGE*	ERROR
MX7524JN	0°C to +70°C	Plastic DIP	$\pm\frac{1}{2}$ LSB
MX7524KN	0°C to +70°C	Plastic DIP	$\pm\frac{1}{4}$ LSB
MX7524LN	0°C to +70°C	Plastic DIP	$\pm\frac{1}{8}$ LSB
MX7524JCSE	0°C to +70°C	Small Outline	$\pm\frac{1}{2}$ LSB
MX7524KCSE	0°C to +70°C	Small Outline	$\pm\frac{1}{4}$ LSB
MX7524LCSE	0°C to +70°C	Small Outline	$\pm\frac{1}{8}$ LSB
MX7524J/D	0°C to +70°C	Dice	$\pm\frac{1}{2}$ LSB
MX7524AD	-25°C to +85°C	Ceramic	$\pm\frac{1}{2}$ LSB
MX7524BD	-25°C to +85°C	Ceramic	$\pm\frac{1}{4}$ LSB
MX7524CD	-25°C to +85°C	Ceramic	$\pm\frac{1}{8}$ LSB

\* All devices — 16 lead packages

\*\* Maxim reserves the right to ship Ceramic packages in lieu of CERDIP packages

(Ordering Information continued on last page)

### Pin Configuration

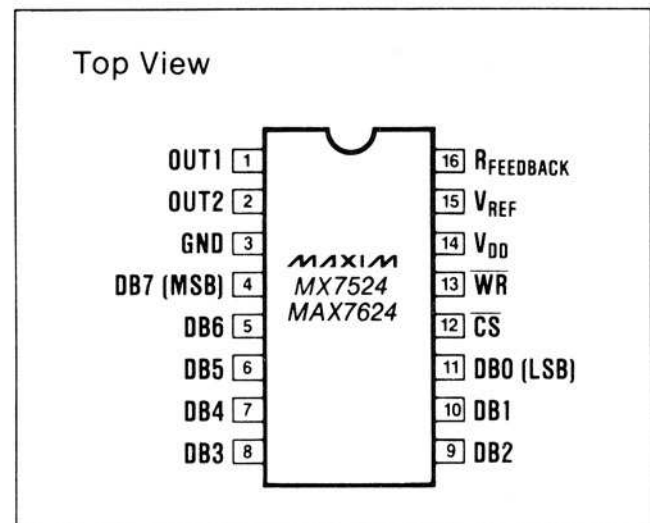

# CMOS 8-Bit Buffered Multiplying DACs

## ABSOLUTE MAXIMUM RATINGS—MX7524, MAX7624

V <sub>DD</sub> to GND	-0.3V, +17V	Operating Temperature Ranges (continued)	
V <sub>REF</sub> to GND	±25V	MX7524AD, AQ, BD, BQ, CD, CQ	-25°C to +85°C
V <sub>RFB</sub> to GND	±25V	MAX7624EPE	-40°C to +85°C
Digital Input Voltage to GND	-0.3V to V <sub>DD</sub> + 0.3V	MX7524SD, SQ, TD, TQ, UD, UQ	
OUT1, OUT2 to GND	-0.3V, V <sub>DD</sub>	MAX7624MJE	-55°C to +125°C
Operating Temperature Ranges		Storage Temperature Range	-65°C to +160°C
MX7524JN, KN, LN, JCSE, KCSE, LCSE		Power Dissipation (any Package) to +75°C	450mW
MAX7624CPE, CSE	0°C to +70°C	Derate Above +75°C by	6 mW/°C
		Lead Temperature (Soldering 10 seconds)	+300°C

Stresses above those listed under "Absolute Maximum Ratings" may cause permanent damage to the devices. These are stress ratings only, and functional operation of the device at these or any other conditions above those indicated in the operational sections of the specifications is not implied. Exposure to absolute maximum ratings conditions for extended periods may affect device reliability.

## ELECTRICAL CHARACTERISTICS—MX7524, +5V Operation

(V<sub>DD</sub> = +5V; V<sub>REF</sub> = +10V; V<sub>OUT1</sub> = V<sub>OUT2</sub> = 0V; T<sub>A</sub> = T<sub>MIN</sub> to T<sub>MAX</sub> unless otherwise noted)

PARAMETER	SYMBOL	CONDITIONS	MIN	TYP	MAX	UNITS
<b>DC ACCURACY</b>						
Resolution			8			Bits
Relative Accuracy	INL	J,A,S K,B,T L,C,U			±1/2 ±1/2 ±1/2	LSB
Differential Non-Linearity	DNL	All Grades Guaranteed Monotonic Over Temp.			±1	LSB
Gain Error (Note 1)		T <sub>A</sub> = 25°C T <sub>A</sub> = T <sub>MIN</sub> to T <sub>MAX</sub>			±2½ ±3½	LSB
Gain Temp. Coefficient (Note 2, 3)				±2	±40	ppm/°C
Supply Rejection (Note 2)	PSR	ΔV <sub>DD</sub> = ±10% T <sub>A</sub> = 25°C T <sub>A</sub> = T <sub>MIN</sub> to T <sub>MAX</sub>		0.002 0.01	0.08 0.16	%FSR/%
Output Leakage Current (I <sub>OUT1</sub> )		V <sub>REF</sub> = ±10V DAC is 00000000 T <sub>A</sub> = 25°C T <sub>A</sub> = T <sub>MIN</sub> to T <sub>MAX</sub>			±50 ±400	nA
Output Leakage Current (I <sub>OUT2</sub> )		V <sub>REF</sub> = ±10V DAC is 11111111 T <sub>A</sub> = 25°C T <sub>A</sub> = T <sub>MIN</sub> to T <sub>MAX</sub>			±50 ±400	nA
<b>REFERENCE INPUT</b>						
R <sub>IN</sub> (pin 15 to GND)			5	10	20	kΩ
<b>DYNAMIC PERFORMANCE</b>						
Output Current Settling-Time to 1/2 LSB (Note 2)		DB0-DB7 = 0V to V <sub>DD</sub> to 0V WR = CS = 0V OUT1 Load = 100Ω, C <sub>EXT</sub> = 13pF; T <sub>A</sub> = 25°C T <sub>A</sub> = T <sub>MIN</sub> to T <sub>MAX</sub>			400 500	ns
AC Feedthrough (OUT1 or OUT2) (Note 2)		V <sub>REF</sub> = ±10V 100kHz Sinewave DB0-DB7 = WR = CS = 0V T <sub>A</sub> = 25°C T <sub>A</sub> = T <sub>MIN</sub> to T <sub>MAX</sub>			0.25 0.5	%FSR
<b>ANALOG OUTPUTS</b>						
OUT1 Capacitance (Note 2)	C <sub>OUT1</sub>	DB0-DB7 = V <sub>DD</sub> ; WR = CS = 0V DB0-DB7 = 0V; WR = CS = 0V			120 30	pF
OUT2 Capacitance (Note 2)	C <sub>OUT2</sub>	DB0-DB7 = V <sub>DD</sub> ; WR = CS = 0V DB0-DB7 = 0V; WR = CS = 0V			30 120	pF

**Note 1:** Gain error is measured using internal feedback resistor. Full Scale Range (FSR) = V<sub>REF</sub>.

**Note 2:** Guaranteed, but not tested.

**Note 3:** Gain error measured from 25°C to T<sub>MAX</sub> or from 25°C to T<sub>MIN</sub>.

**Note 4:** Sample tested at 25°C to ensure compliance.

# CMOS 8-Bit Buffered Multiplying DACs

MX7524/MAX7624

## ELECTRICAL CHARACTERISTICS—MX7524, +5V Operation (Continued)

( $V_{DD} = +5V$ ,  $V_{REF} = +10V$ ;  $V_{OUT1} = V_{OUT2} = 0V$ ;  $T_A = T_{MIN}$  to  $T_{MAX}$  unless otherwise noted)

PARAMETER	SYMBOL	CONDITIONS	MIN	TYP	MAX	UNITS
<b>DIGITAL INPUTS</b>						
Input High Voltage	$V_{IH}$		2.4			V
Input Low Voltage	$V_{IL}$				0.8	V
Input Current	$I_{IN}$	$T_A = 25^\circ C$ ; $V_{IN} = 0V$ or $V_{DD}$ $T_A = T_{MIN}$ to $T_{MAX}$			$\pm 1$ $\pm 10$	$\mu A$
Input Capacitance (Note 2)	$C_{IN}$	DB0-DB7 WR, CS			8 20	pF
<b>POWER REQUIREMENTS</b>						
Supply Current	$I_{DD}$	Digital inputs $V_{IL}$ or $V_{IH}$ $T_A = 25^\circ C$ $T_A = T_{MIN}$ to $T_{MAX}$			1 2	mA
		Digital inputs $0V$ or $V_{DD}$ $T_A = 25^\circ C$ $T_A = T_{MIN}$ to $T_{MAX}$			100 500	$\mu A$
<b>SWITCHING CHARACTERISTICS (Note 4) (See Timing Diagram)</b>						
Chip Select to Write Setup Time	$t_{CS}$	$T_A = 25^\circ C$ $T_A = T_{MIN}$ to $T_{MAX}$ J,K,L,A,B,C $T_A = T_{MIN}$ to $T_{MAX}$ S,T,U	170 220 240			ns
Chip Select to Write Hold Time	$t_{CH}$		0			ns
Write Pulse Width	$t_{WR}$	$T_A = 25^\circ C$ $T_A = T_{MIN}$ to $T_{MAX}$ J,K,L,A,B,C $T_A = T_{MIN}$ to $T_{MAX}$ S,T,U	170 220 240			ns
Data Setup Time	$t_{DS}$	$T_A = 25^\circ C$ $T_A = T_{MIN}$ to $T_{MAX}$ J,K,L,A,B,C $T_A = T_{MIN}$ to $T_{MAX}$ S,T,U	135 170 170			ns
Data Hold Time	$t_{DH}$		10			ns

## ELECTRICAL CHARACTERISTICS—MX7524, +15V Operation

( $V_{DD} = +15V$ ;  $V_{REF} = +10V$ ;  $V_{OUT1} = V_{OUT2} = 0V$ ;  $T_A = T_{MIN}$  to  $T_{MAX}$  unless otherwise noted)

PARAMETER	SYMBOL	CONDITIONS	MIN	TYP	MAX	UNITS
<b>DC ACCURACY</b>						
Resolution			8			Bits
Relative Accuracy	INL	J,A,S K,B,T L,C,U			$\pm 1/2$ $\pm 1/4$ $\pm 1/8$	LSB
Differential Non-Linearity	DNL	All Grades Guaranteed Monotonic Over Temp.			$\pm 1$	LSB
Gain Error (Note 1)		$T_A = 25^\circ C$ $T_A = T_{MIN}$ to $T_{MAX}$			$\pm 1/4$ $\pm 1/2$	LSB
Gain Temp. Coefficient (Note 2, 3)				$\pm 1$	$\pm 10$	ppm/ $^\circ C$
Supply Rejection (Note 2)	PSR	$\Delta V_{DD} = \pm 10\%$ $T_A = 25^\circ C$ $T_A = T_{MIN}$ to $T_{MAX}$		0.001 0.005	0.02 0.04	%FSR/%
Output Leakage Current ( $I_{OUT1}$ )		$V_{REF} = \pm 10V$ DAC is 00000000 $T_A = 25^\circ C$ $T_A = T_{MIN}$ to $T_{MAX}$			$\pm 50$ $\pm 200$	nA
Output Leakage Current ( $I_{OUT2}$ )		$V_{REF} = \pm 10V$ DAC is 11111111 $T_A = 25^\circ C$ $T_A = T_{MIN}$ to $T_{MAX}$			$\pm 50$ $\pm 200$	nA

# CMOS 8-Bit Buffered Multiplying DACs

## ELECTRICAL CHARACTERISTICS—MX7524, +15V Operation (Continued)

( $V_{DD} = +15V$ ;  $V_{REF} = +10V$ ;  $V_{OUT1} = V_{OUT2} = 0V$ ;  $T_A = T_{MIN}$  to  $T_{MAX}$  unless otherwise noted)

PARAMETER	SYMBOL	CONDITIONS	MIN	TYP	MAX	UNITS
<b>REFERENCE INPUT</b>						
$R_{IN}$ (pin 15 to GND)			5	10	20	k $\Omega$
<b>DYNAMIC PERFORMANCE</b>						
Output Current Settling-Time to 1/2 LSB (Note 2)		DB0-DB7 = 0V to $V_{DD}$ to 0V WR = CS = 0V OUT1 Load = 100 $\Omega$ , $C_{EXT} = 13pF$ ; $T_A = 25^\circ C$ $T_A = T_{MIN}$ to $T_{MAX}$			250 350	ns
AC Feedthrough (OUT1 or OUT2) (Note 2)		$V_{REF} = \pm 10V$ 100kHz Sinewave DB0-DB7 = WR = CS = 0V $T_A = 25^\circ C$ $T_A = T_{MIN}$ to $T_{MAX}$			0.25 0.5	%FSR
<b>ANALOG OUTPUTS</b>						
OUT1 Capacitance (Note 2)	$C_{OUT1}$	DB0-DB7 = $V_{DD}$ ; $\overline{WR} = \overline{CS} = 0V$ DB0-DB7 = 0V; $\overline{WR} = \overline{CS} = 0V$			120 30	pF
OUT2 Capacitance (Note 2)	$C_{OUT2}$	DB0-DB7 = $V_{DD}$ ; $\overline{WR} = \overline{CS} = 0V$ DB0-DB7 = 0V; $\overline{WR} = \overline{CS} = 0V$			30 120	pF
<b>DIGITAL INPUTS</b>						
Input High Voltage	$V_{IH}$		13.5			V
Input Low Voltage	$V_{IL}$				1.5	V
Input Current	$I_{IN}$	$T_A = 25^\circ C$ ; $V_{IN} = 0V$ or $V_{DD}$ $T_A = T_{MIN}$ to $T_{MAX}$			$\pm 1$ $\pm 10$	$\mu A$
Input Capacitance (Note 2)	$C_{IN}$	DB0-DB7 WR, CS			8 20	pF
<b>POWER REQUIREMENTS</b>						
Supply Current	$I_{DD}$	Digital inputs $V_{IL}$ or $V_{IH}$			2	mA
		Digital inputs 0V or $V_{DD}$	$T_A = 25^\circ C$ $T_A = T_{MIN}$ to $T_{MAX}$		100 500	$\mu A$
<b>SWITCHING CHARACTERISTICS</b> (Note 4) (See Timing Diagram)						
Chip Select to Write Setup Time	$t_{CS}$	$T_A = 25^\circ C$ $T_A = T_{MIN}$ to $T_{MAX}$ $T_A = T_{MIN}$ to $T_{MAX}$ J,K,L,A,B,C S,T,U			100 130 150	ns
Chip Select to Write Hold Time	$t_{CH}$				0	ns
Write Pulse Width	$t_{WR}$	$T_A = 25^\circ C$ $T_A = T_{MIN}$ to $T_{MAX}$ $T_A = T_{MIN}$ to $T_{MAX}$ J,K,L,A,B,C S,T,U			100 130 150	ns
Data Setup Time	$t_{DS}$	$T_A = 25^\circ C$ $T_A = T_{MIN}$ to $T_{MAX}$ $T_A = T_{MIN}$ to $T_{MAX}$ J,K,L,A,B,C S,T,U			60 80 100	ns
Data Hold Time	$t_{DH}$				10	ns

**Note 1:** Gain error is measured using internal feedback resistor. Full Scale Range (FSR) =  $V_{REF}$ .

**Note 2:** Guaranteed, but not tested.

**Note 3:** Gain error measured from  $25^\circ C$  to  $T_{MAX}$  or from  $25^\circ C$  to  $T_{MIN}$ .

**Note 4:** Sample tested at  $25^\circ C$  to ensure compliance.

# CMOS 8-Bit Buffered Multiplying DACs

MX7524/MAX7624

## ELECTRICAL CHARACTERISTICS—MAX7624, +12V to +15V Operation

( $V_{DD} = +10.8V$  to  $+15.75V$ ;  $V_{REF} = +10V$ ;  $V_{OUT1} = V_{OUT2} = 0V$ ;  $T_A = T_{MIN}$  to  $T_{MAX}$  unless otherwise noted)

PARAMETER	SYMBOL	CONDITIONS	MIN	TYP	MAX	UNITS
<b>DC ACCURACY</b>						
Resolution			8			Bits
Relative Accuracy	INL				±1/2	LSB
Differential Non-Linearity	DNL	All Grades Guaranteed Monotonic Over Temp.			±1	LSB
Gain Error (Note 1)					±2	LSB
Gain Temp. Coefficient (Note 2, 3)				±1	±10	ppm/°C
Supply Rejection (Note 2)	PSR	$V_{DD} = +10.8V$ to $+15.75V$ $T_A = 25^\circ C$ $T_A = T_{MIN}$ to $T_{MAX}$		0.001 0.005	0.02 0.04	%FSR/%
Output Leakage Current ( $I_{OUT1}$ )		$V_{REF} = \pm 10V$ DAC is 00000000 $T_A = 25^\circ C$ $T_A = T_{MIN}$ to $T_{MAX}$			±50 ±200	nA
Output Leakage Current ( $I_{OUT2}$ )		$V_{REF} = \pm 10V$ DAC is 11111111 $T_A = 25^\circ C$ $T_A = T_{MIN}$ to $T_{MAX}$			±50 ±200	nA
<b>REFERENCE INPUT</b>						
$R_{IN}$ (pin 15 to GND)			5	10	20	kΩ
<b>DYNAMIC PERFORMANCE</b>						
Output Current Settling-Time to 1/2 LSB (Note 2)		DB0-DB7 = 0V to +5V to 0V WR = CS = 0V OUT1 Load = 100Ω, $C_{EXT} = 13pF$ ; $T_A = 25^\circ C$ $T_A = T_{MIN}$ to $T_{MAX}$			250 350	ns
AC Feedthrough (OUT1 or OUT2) (Note 2)		$V_{REF} = \pm 10V$ 100kHz Sinewave DB0-DB7 = WR = CS = 0V $T_A = 25^\circ C$ $T_A = T_{MIN}$ to $T_{MAX}$			0.25 0.5	%FSR
<b>ANALOG OUTPUTS</b>						
OUT1 Capacitance (Note 2)	$C_{OUT1}$	DB0-DB7 = +5V; $\overline{WR} = \overline{CS} = 0V$ DB0-DB7 = 0V; $\overline{WR} = \overline{CS} = 0V$			60 25	pF
OUT2 Capacitance (Note 2)	$C_{OUT2}$	DB0-DB7 = +5V; $\overline{WR} = \overline{CS} = 0V$ DB0-DB7 = 0V; $\overline{WR} = \overline{CS} = 0V$			25 60	pF
<b>DIGITAL INPUTS</b>						
Input High Voltage	$V_{IH}$		2.4			V
Input Low Voltage	$V_{IL}$				0.8	V
Input Current	$I_{IN}$	$T_A = 25^\circ C$ ; $V_{IN} = 0V$ or $V_{DD}$ $T_A = T_{MIN}$ to $T_{MAX}$			±1 ±10	μA
Input Capacitance (Note 2)	$C_{IN}$	DB0-DB7, $\overline{WR}$ , $\overline{CS}$			8	pF
<b>POWER REQUIREMENTS</b>						
Supply Current	$I_{DD}$	Digital inputs $V_{IL}$ or $V_{IH}$			2.5	mA
		Digital inputs 0V or $V_{DD}$ $T_A = 25^\circ C$ $T_A = T_{MIN}$ to $T_{MAX}$			100 500	μA

# CMOS 8-Bit Buffered Multiplying DACs

## ELECTRICAL CHARACTERISTICS—MAX7624, +12V to +15V Operation (Continued)

( $V_{DD} = +10.8V$  to  $+15.75V$ ,  $V_{REF} = +10V$ ;  $V_{OUT1} = V_{OUT2} = 0V$ ;  $T_A = T_{MIN}$  to  $T_{MAX}$  unless otherwise noted)

PARAMETER	SYMBOL	CONDITIONS	MIN	TYP	MAX	UNITS
<b>SWITCHING CHARACTERISTICS</b> (Note 4) (See Timing Diagram)						
Chip Select to Write Setup Time	$t_{CS}$	$T_A = 25^\circ C$ $T_A = T_{MIN}$ to $T_{MAX}$ C,E $T_A = T_{MIN}$ to $T_{MAX}$ M	160	160	210	ns
Chip Select to Write Hold Time	$t_{CH}$		10			ns
Write Pulse Width	$t_{WR}$	$T_A = 25^\circ C$ $T_A = T_{MIN}$ to $T_{MAX}$ C,E $T_A = T_{MIN}$ to $T_{MAX}$ M	150	170	210	ns
Data Setup Time	$t_{DS}$	$T_A = 25^\circ C$ $T_A = T_{MIN}$ to $T_{MAX}$ C,E $T_A = T_{MIN}$ to $T_{MAX}$ M	160	160	210	ns
Data Hold Time	$t_{DH}$		10			ns

### Detailed Description

The MX7524/MAX7624 is an 8-bit multiplying digital-to-analog converter (DAC) that consists of a thin-film R-2R resistor array with CMOS current steering switches. In applications requiring a voltage output, an output operational amplifier and reference will be needed. Figure 1 shows a simplified schematic of the DAC. The inverted R-2R ladder divides the voltage or current reference in a binary manner among the eight steering switches. The magnitude of the current appearing at either OUT terminal depends on the number of switches selected, and therefore the output is an analog representation of the digital input. The two OUT terminals must be held at the same potential so a constant current is maintained in each ladder leg. This makes the  $V_{REF}$  input current independent of switch state and also ensures that the MX7524/MAX7624 maintains its excellent linearity performance.

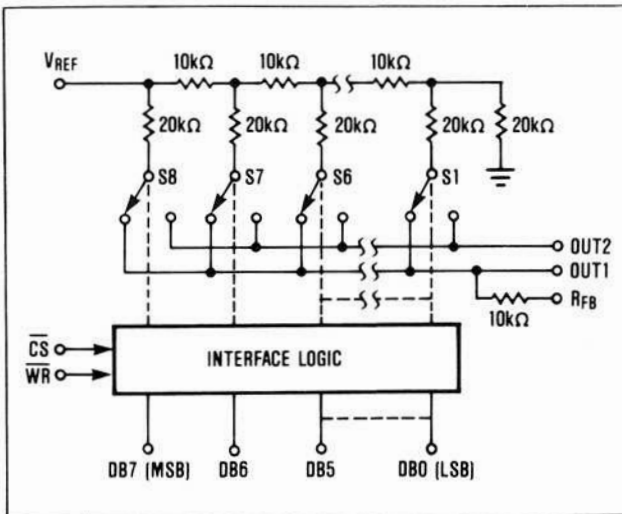

Figure 1. MX7524/MAX7624 Functional Diagram

### Equivalent-Circuit Analysis

The equivalent circuit for all digital inputs LOW is shown in figure 2. In this state the reference current is switched to OUT2. The current source,  $I_{LEAKAGE}$ , is composed of small surface and junction leakages to the substrate which double every  $10^\circ C$ . The R-2R ladder termination resistor generates a constant  $1/256$  current which represents 1 LSB of the reference current,  $I_{REF}$ . The value of output capacitance at the OUT1 and OUT2 terminals is input code dependent and lies in the range 20pF to 30pF.

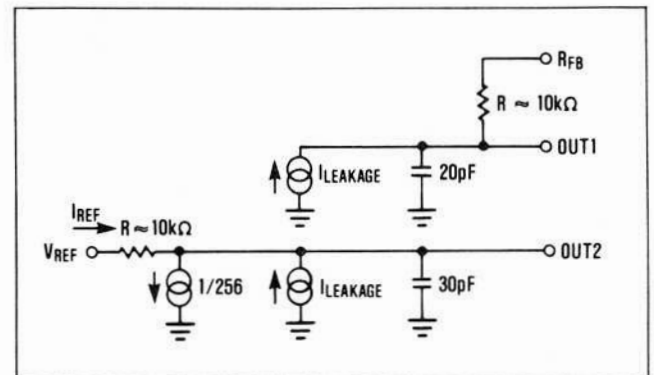

Figure 2. MX7524/MAX7624 DAC Equivalent Circuit—All Digital Inputs LOW

The MX7524's digital inputs are TTL compatible when operated with a  $V_{DD}$  of +5V ( $V_{IH} = 2.4V$ ,  $V_{IL} = 0.8V$ ). Internal level shifters convert from TTL to CMOS logic levels. When  $V_{IN}$  is in the region 1.5 to 3.5 volts, the input buffers operate in their linear region and the quiescent current increases as indicated by the graph in figure 3. Therefore to minimize supply current it is recommended that the digital inputs be as close to the supply rails as possible ( $V_{DD}$  and DGND).

# CMOS 8-Bit Buffered Multiplying DACs

The MX7524 may be operated with any supply voltage in the range  $5V < V_{DD} < 15V$ . With  $V_{DD} = +15V$  the input logic levels are CMOS compatible only, i.e. 1.5V and 13.5V.

The MAX7624's digital inputs are TTL/CMOS compatible for a +12V to +15V supply range. However, when  $V_{IN}$  is in the range of 1.5V to  $V_{DD} - 1.5V$  the input buffers operate in their linear region and the quiescent current increases (see figure 3).

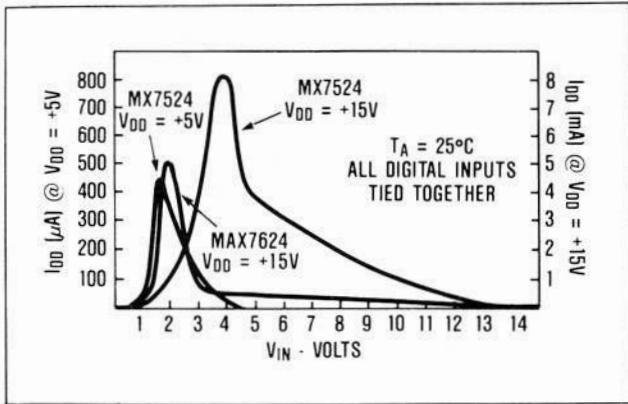

Figure 3. Typical Supply Current,  $I_{DD}$  vs. Logic Input Voltage  $V_{IN}$  for  $V_{DD} = +5V$  and  $+15V$

## Interface Logic Information

### Mode Selection

The inputs  $\overline{CS}$  and  $\overline{WR}$  control the operating mode of the MX7524/MAX7624. See Mode Selection Table.

### Mode Selection Table

$\overline{CS}$	$\overline{WR}$	MODE	DAC RESPONSE
L	L	WRITE	DAC responds to data bus (DB0-DB7) inputs
H	X	HOLD	Data bus (DB0-DB7) is locked out; DAC holds last data present when $\overline{CS}$ or $\overline{WR}$ assumed HIGH state

L = Low State, H = High State, X = Don't Care

### Write Mode

When  $\overline{CS}$  and  $\overline{WR}$  are both LOW, the MX7524/MAX7624 is in the write mode, and the MX7524/MAX7624 analog output responds to data activity at the DB0-DB7 data bus inputs. In this mode, the data latches are transparent.

### Hold Mode

The MX7524/MAX7624 retains the data that was present on DB0-DB7 just prior to  $\overline{CS}$  or  $\overline{WR}$  assuming a high state. The analog output remains at the value corresponding to the digital code locked in the data latch.

### Write Cycle Timing Diagram

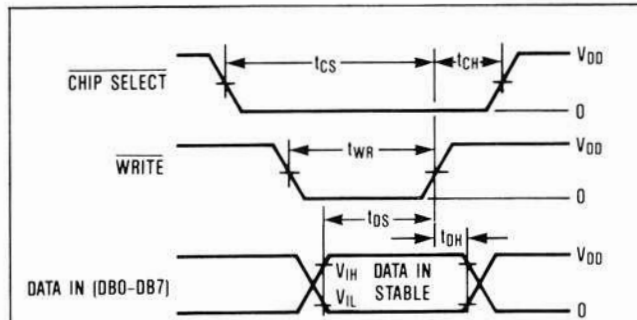

#### NOTES:

- FOR THE MX7524 ALL INPUT SIGNAL RISE AND FALL TIMES ARE MEASURED FROM 10% TO 90% OF  $V_{DD}$ .  $V_{DD} = +5V$ ,  $t_r = t_f = 20ns$ ;  $V_{DD} = +15V$ ,  $t_r = t_f = 40ns$ .
- FOR THE MAX7624 ALL INPUT SIGNAL RISE AND FALL TIMES ARE MEASURED FROM 10% TO 90% OF +5V.
- TIMING MEASUREMENT REFERENCE LEVEL IS  $(V_{IH} + V_{IL})/2$ .

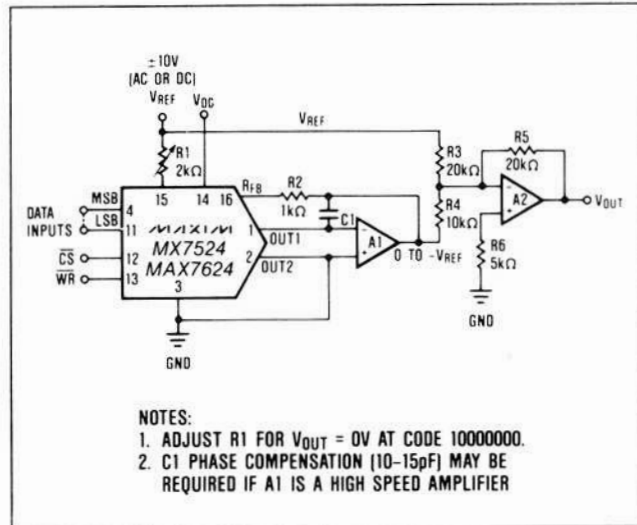

#### NOTES:

- ADJUST R1 FOR  $V_{OUT} = 0V$  AT CODE 10000000.
- C1 PHASE COMPENSATION (10-15pF) MAY BE REQUIRED IF A1 IS A HIGH SPEED AMPLIFIER

Figure 4. Bipolar (4-Quadrant) Operation

# CMOS 8-Bit Buffered Multiplying DACs

## Ordering Information (continued)

PART	TEMP. RANGE	PACKAGE*	ERROR
MX7524AQ	-25°C to +85°C	CERDIP**	±½ LSB
MX7524BQ	-25°C to +85°C	CERDIP**	±¼ LSB
MX7524CQ	-25°C to +85°C	CERDIP**	±½ LSB
MX7524SD	-55°C to +125°C	Ceramic	±½ LSB
MX7524TD	-55°C to +125°C	Ceramic	±¼ LSB
MX7524UD	-55°C to +125°C	Ceramic	±½ LSB
MX7524SQ	-55°C to +125°C	CERDIP**	±½ LSB
MX7524TQ	-55°C to +125°C	CERDIP**	±¼ LSB
MX7524UQ	-55°C to +125°C	CERDIP**	±½ LSB
MAX7624CPE	0°C to +70°C	Plastic DIP	±½ LSB
MAX7624CSE	0°C to +70°C	Small Outline	±½ LSB
MAX7624C/D	0°C to +70°C	Dice	±½ LSB
MAX7624EPE	-40°C to +85°C	Plastic DIP	±½ LSB
MAX7624MJE	-55°C to +125°C	CERDIP	±½ LSB

\* All devices — 16 lead packages

\*\* Maxim reserves the right to ship Ceramic packages in lieu of CERDIP packages.

## Chip Topography

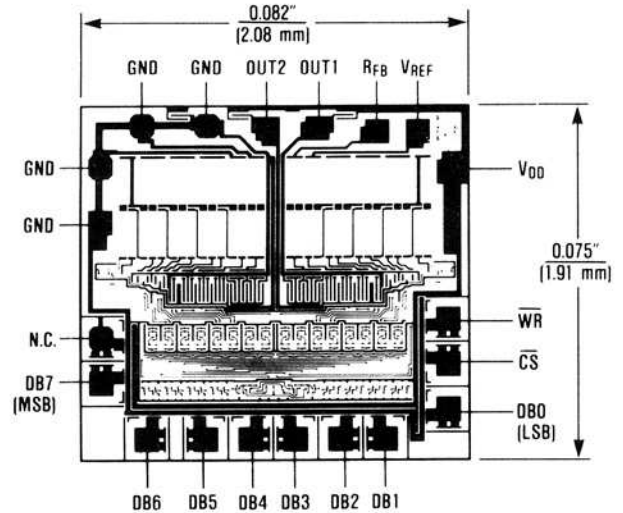

**Table 1. Unipolar Binary Code Table**

DIGITAL INPUT MSB	LSB	ANALOG OUTPUT
1	1	$-V_{REF} \left( \frac{255}{256} \right)$
1	0	$-V_{REF} \left( \frac{129}{256} \right)$
1	0	$-V_{REF} \left( \frac{128}{256} \right) = -\frac{V_{REF}}{2}$
0	1	$-V_{REF} \left( \frac{127}{128} \right)$
0	0	$-V_{REF} \left( \frac{1}{256} \right)$
0	0	$-V_{REF} \left( \frac{0}{256} \right) = 0$

Note: 1LSB =  $(2^{-8})(V_{REF}) = \frac{1}{256}(V_{REF})$

**Table 2. Bipolar (Offset Binary) Code Table**

DIGITAL INPUT MSB	LSB	ANALOG OUTPUT
1	1	$+V_{REF} \left( \frac{127}{128} \right)$
1	0	$+V_{REF} \left( \frac{1}{128} \right)$
1	0	0
0	1	$-V_{REF} \left( \frac{1}{128} \right)$
0	0	$-V_{REF} \left( \frac{127}{128} \right)$
0	0	$-V_{REF} \left( \frac{128}{128} \right)$

Note: 1LSB =  $(2^{-7})(V_{REF}) = \frac{1}{128}(V_{REF})$

Maxim cannot assume responsibility for use of any circuitry other than circuitry entirely embodied in a Maxim product. No circuit patent licenses are implied. Maxim reserves the right to change the circuitry and specifications without notice at any time.

8 Maxim Integrated Products, 120 San Gabriel Drive, Sunnyvale, CA 94086 (408) 737-7600