

●Features

- 1) Ultra low-ohmic resistance range (1mΩ ~)
- 2) Improved current detection accuracy by trimming-less structure.
- 3) Special low resistance temperature coefficient.
- 4) The unique chip structure minimizes thermal stress during temperature cycling, resulting in greater reliability.
- 5) ROHM resistors have obtained ISO9001 / ISO / TS16949 certification.
- 6) Corresponds to AEC-Q200. (PMR50 / 100)

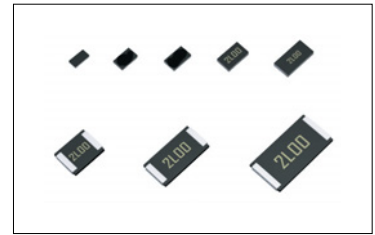

●Products List

Part No.	Size		Rated Power (70°C) (W)	Temperature Coefficient (ppm / °C)	Resistance Tolerance (%)	Resistance Range	Operating Temperature Range (°C)
	(mm)	(inch)					
☆ PMR006	0603	0201	0.1	0 to 300	J(±5%)	10mΩ	-55 to +155
PMR01	1005	0402	0.2	0 to 200	J(±5%)	10mΩ	
PMR03	1608	0603	0.25	0 to 150	J(±5%) F(±1%)	10mΩ	
PMR10	2012	0805	0.5	±150	J(±5%) G(±2%) F(±1%)	2,3,4,5,6,7,8,9,10mΩ	
PMR18	3216	1206	1	±100	J(±5%) F(±1%)	1,2,3,4,5,6,7,8,9,10mΩ	
PMR25	3225	1210	1	±100	J(±5%) F(±1%)	1,2,3,4,5mΩ	
PMR50	5025	2010	1	±100	J(±5%) F(±1%)	1,2,3,4,5,6,7,8,9,10mΩ	
PMR100	6432	2512	2	±100 *	J(±5%) F(±1%)	1,2,3,4,5,6,7,8,9,10mΩ	

☆: Under development

* : ± 150ppm / °C (1mΩ, 2mΩ Only)

Design and specifications are subject to change without notice.

Carefully check the specification sheet supplied with the product before using or ordering it.

●Part Number Description

P M R	2 5	H Z P	J	V	2 L 0																																																																					
Part No. PMR (Ultra-low Ohmic Chip Resistors for Current Detection)	Size (mm [inch]) 006 (0603 [0201]) 01 (1005 [0402]) 03 (1608 [0603]) 10 (2012 [0805]) 18 (3216 [1206]) 25 (3225 [1210]) 50 (5025 [2010]) 100 (6432 [2512])	Packaging specifications code	Resistance Tolerance F (±1%) G (±2%) J (±5%)	Special part code U : 5 to 10mΩ V : 1 to 4mΩ	Nominal Resistance Resistance code, 3 or 4 digits. Resistance Value(Ω) Resistance Tolerance J F,G																																																																					
		<table border="1"> <thead> <tr> <th>Part No.</th> <th>Code</th> <th>Packaging specifications</th> <th>Quantity / Reel</th> </tr> </thead> <tbody> <tr> <td>PMR006</td> <td>YZP</td> <td>Paper tape (2mm Pitch)</td> <td>15,000</td> </tr> <tr> <td>PMR01</td> <td>MZP</td> <td>Paper tape (2mm Pitch)</td> <td>10,000</td> </tr> <tr> <td>PMR03</td> <td>EZP</td> <td>Paper tape (4mm Pitch)</td> <td>5,000</td> </tr> <tr> <td>PMR10</td> <td>EZP</td> <td>Paper tape (4mm Pitch)</td> <td>5,000</td> </tr> <tr> <td>PMR18</td> <td>EZP</td> <td>Paper tape (4mm Pitch)</td> <td>5,000</td> </tr> <tr> <td>PMR25</td> <td>HZP</td> <td>Embossed tape (4mm Pitch)</td> <td>2,000</td> </tr> <tr> <td>PMR50</td> <td>HZP</td> <td>Embossed tape (4mm Pitch)</td> <td>2,000</td> </tr> <tr> <td>PMR100</td> <td>HZP</td> <td>Embossed tape (4mm Pitch)</td> <td>2,000</td> </tr> </tbody> </table>	Part No.	Code	Packaging specifications	Quantity / Reel	PMR006	YZP	Paper tape (2mm Pitch)	15,000	PMR01	MZP	Paper tape (2mm Pitch)	10,000	PMR03	EZP	Paper tape (4mm Pitch)	5,000	PMR10	EZP	Paper tape (4mm Pitch)	5,000	PMR18	EZP	Paper tape (4mm Pitch)	5,000	PMR25	HZP	Embossed tape (4mm Pitch)	2,000	PMR50	HZP	Embossed tape (4mm Pitch)	2,000	PMR100	HZP	Embossed tape (4mm Pitch)	2,000			<table border="1"> <thead> <tr> <th>Resistance Value(Ω)</th> <th>J</th> <th>F,G</th> </tr> </thead> <tbody> <tr><td>1mΩ</td><td>1L0</td><td>1L00</td></tr> <tr><td>2mΩ</td><td>2L0</td><td>2L00</td></tr> <tr><td>3mΩ</td><td>3L0</td><td>3L00</td></tr> <tr><td>4mΩ</td><td>4L0</td><td>4L00</td></tr> <tr><td>5mΩ</td><td>5L0</td><td>5L00</td></tr> <tr><td>6mΩ</td><td>6L0</td><td>6L00</td></tr> <tr><td>7mΩ</td><td>7L0</td><td>7L00</td></tr> <tr><td>8mΩ</td><td>8L0</td><td>8L00</td></tr> <tr><td>9mΩ</td><td>9L0</td><td>9L00</td></tr> <tr><td>10mΩ</td><td>10L</td><td>10L0</td></tr> </tbody> </table>	Resistance Value(Ω)	J	F,G	1mΩ	1L0	1L00	2mΩ	2L0	2L00	3mΩ	3L0	3L00	4mΩ	4L0	4L00	5mΩ	5L0	5L00	6mΩ	6L0	6L00	7mΩ	7L0	7L00	8mΩ	8L0	8L00	9mΩ	9L0	9L00	10mΩ	10L	10L0
Part No.	Code	Packaging specifications	Quantity / Reel																																																																							
PMR006	YZP	Paper tape (2mm Pitch)	15,000																																																																							
PMR01	MZP	Paper tape (2mm Pitch)	10,000																																																																							
PMR03	EZP	Paper tape (4mm Pitch)	5,000																																																																							
PMR10	EZP	Paper tape (4mm Pitch)	5,000																																																																							
PMR18	EZP	Paper tape (4mm Pitch)	5,000																																																																							
PMR25	HZP	Embossed tape (4mm Pitch)	2,000																																																																							
PMR50	HZP	Embossed tape (4mm Pitch)	2,000																																																																							
PMR100	HZP	Embossed tape (4mm Pitch)	2,000																																																																							
Resistance Value(Ω)	J	F,G																																																																								
1mΩ	1L0	1L00																																																																								
2mΩ	2L0	2L00																																																																								
3mΩ	3L0	3L00																																																																								
4mΩ	4L0	4L00																																																																								
5mΩ	5L0	5L00																																																																								
6mΩ	6L0	6L00																																																																								
7mΩ	7L0	7L00																																																																								
8mΩ	8L0	8L00																																																																								
9mΩ	9L0	9L00																																																																								
10mΩ	10L	10L0																																																																								

●Chip Resistor Dimensions and Markings

■ PMR006 / 01 / 03 / 10 / 18

■ PMR25 / 50 / 100

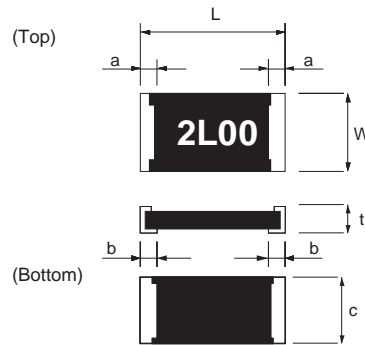
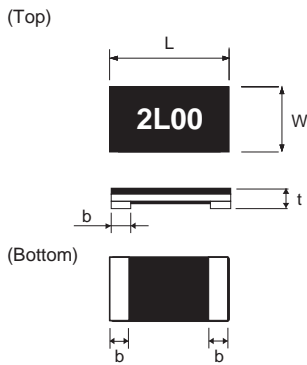

<Marking method>

There are four digits used for the calculation number "L" is used for the decimal point of mΩ.

Ex.) 2mΩ=2L00
10mΩ=10L0

(Unit : mm)

Part No.	(mm)	(inch)	L	W	t	a	b	c	Marking existence
☆PMR006	0603	0201	0.6±0.05	0.3±0.05	0.23±0.05	—	0.15±0.05	—	No
PMR01	1005	0402	1.0±0.05	0.5±0.05	0.25±0.1	—	0.3±0.1	—	No
PMR03	1608	0603	1.6±0.15	0.8±0.15	0.25±0.1	—	0.35±0.15	—	No
PMR10	2012	0805	2.0±0.15	1.2±0.15	0.42 to 0.28*±0.15	—	0.75 to 0.35*±0.25	—	Yes
PMR18	3216	1206	3.2±0.15	1.6±0.15	0.42 to 0.28*±0.15	—	1.2 to 0.5*±0.25	—	Yes
PMR25	3225	1210	3.2±0.2	2.5±0.2	0.52 to 0.32*±0.15	0.5±0.2	1.0 to 0.8*±0.2	1.95±0.2	Yes
PMR50	5025	2010	5.0±0.2	2.5±0.2	0.52 to 0.32*±0.15	0.5±0.2	1.85 to 0.9*±0.2	1.95±0.2	Yes
PMR100	6432	2512	6.4±0.25	3.2±0.25	0.52 to 0.32*±0.15	0.5±0.25	2.3 to 1.1*±0.25	2.65±0.25	Yes

☆ : Under development

* : Each value range varies with the resistance. Please contact a ROHM sales representative for further details.

●Land pattern Example

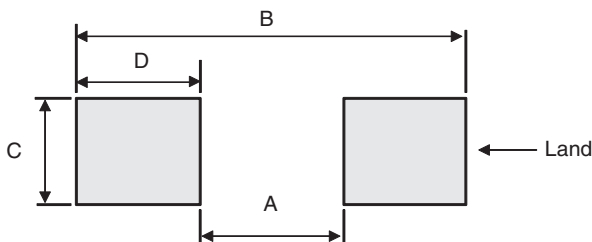

(Unit : mm)

Part No.	A	B	C	D
PMR01	0.5	1.8	0.5	0.65
PMR03	0.5	2.5	0.9	1.0
PMR10	0.8	3.4	1.3	1.3
PMR18	1.0	4.0	1.8	1.5
PMR25	1.0	4.0	2.8	1.5
PMR50	1.8	6.0	2.8	2.1
PMR100	1.2 (1mΩ) 2.4 (2,3,4,6mΩ) 3.0 (5,7,8,9,10mΩ)	6.8 (1mΩ) 7.6 (2 to 10mΩ)	3.4 (1mΩ) 3.8 (2 to 10mΩ)	2.8 (1mΩ) 2.6 (2,3,4,6mΩ) 2.3 (5,7,8,9,10mΩ)

●Derating Curve

When the ambient temperature exceeds 70°C, power dissipation must be adjusted according to the derating curves below.

■ PMR006 / 01 / 03 / 10 / 18 / 25 / 50 / 100

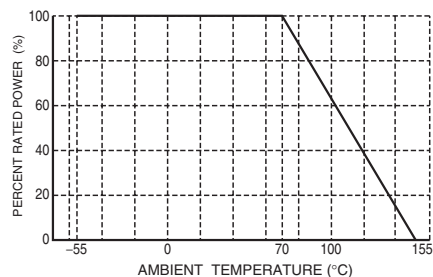

●Characteristics (PMR01 to 100)

Test Items	Guaranteed Value	Test Conditions
	Resistor Type	
Resistance	See P.1	20°C Measuring method : Probes (Under terminations) Measure under terminations by 4 probes.
Variation of resistance with temperature	See P.1	Measurement : +20 / -55 / +20 / +125°C
Overload	± (2.0%+0.0005Ω)	Rated power × 2.5, 2s
Solderability	A new uniform coating of minimum of 95% of the surface being immersed and no soldering damage.	Rosin-Ethanol : 25% (Weight) Soldering condition : 235±5°C Duration of immersion : 2.0±0.5s
Resistance to soldering heat	± (1.0%+0.0005Ω) No remarkable abnormality on the appearance.	Soldering condition : 260±5°C Duration of immersion : 10±1s
Rapid change of temperature	± (1.0%+0.0005Ω)	Test temp. : -55°C to +125°C 5cycle
Damp heat, steady state	± (3.0%+0.0005Ω)	40°C, 93%RH (Relative Humidity) Test time : 1,000h to 1,048h
Endurance at 70°C	± (3.0%+0.0005Ω)	70°C Rated power 1.5h : ON – 0.5h : OFF Test time : 1,000h to 1,048h
Endurance	± (3.0%+0.0005Ω)	155°C Test time : 1,000h to 1,048h
Resistance to solvent	± (0.5%+0.0005Ω)	23±5°C, Immersion cleaning, 5±0.5min Solvent : 2-propanol
Bend strength of the end face plating	Without mechanical damage such as breaks.	–

Compliance Standard(s) : IEC60115-8
JISC 5201-8

●Chip weight (typical value)

Parameter	Unit	PMR01	PMR03	PMR10	PMR18	PMR25	PMR50	PMR100
Weight	mg/pc	0.829	2.12	7.08 (2mΩ)	15.1 (1 to 2mΩ)	32.5 (1mΩ)	45.2 (1 to 2mΩ)	73.8 (1 to 2mΩ)
				6.77 (3 to 5mΩ)	14.3 (3 to 6mΩ)	28.1 (2 to 3mΩ)	40.9 (3 to 5mΩ)	66.9 (3 to 5mΩ)
				4.61 (6 to 8mΩ)	9.77 (7 to 8mΩ)	16.9 (4 to 5mΩ)	25.0 (6 to 10mΩ)	40.3 (6 to 10mΩ)
				3.73 (9 to 10mΩ)	8.01 (9 to 10mΩ)			

●Tape Dimensions

■Paper Tape

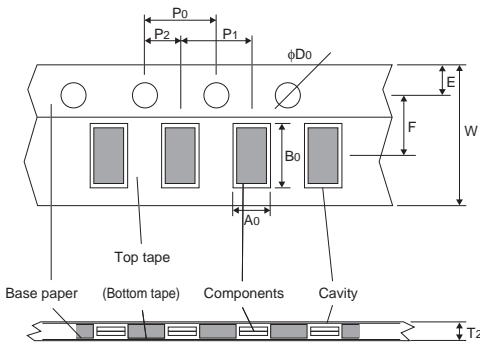

(Unit : mm)

Part No.	W	F	E	A0	B0
PMR01	8.0±0.3	3.5±0.05	1.75±0.1	0.7±0.1	1.2±0.1
PMR03	8.0±0.3	3.5±0.05	1.75±0.1	0.95±0.1	1.75±0.1
PMR10	8.0±0.3	3.5±0.05	1.75±0.1	1.45 ^{+0.2} _{-0.1}	2.3 ^{+0.2} _{-0.1}
PMR18	8.0±0.3	3.5±0.05	1.75±0.1	1.95 ^{+0.1} _{-0.05}	3.5 ^{+0.15} _{-0.05}

Part No.	D0	P0	P1	P2	T2
PMR01	φ1.5 ^{+0.1} ₀	4.0±0.1	2.0±0.05	2.0±0.05	Max 1.1
PMR03	φ1.5 ^{+0.1} ₀	4.0±0.1	4.0±0.1	2.0±0.05	Max 1.1
PMR10	φ1.5 ^{+0.1} ₀	4.0±0.1	4.0±0.1	2.0±0.05	Max 1.1
PMR18	φ1.5 ^{+0.1} ₀	4.0±0.1	4.0±0.1	2.0±0.05	Max 1.1

■Embossed Tape

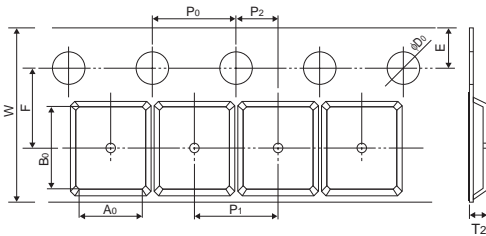

(Unit : mm)

Part No.	W	F	E	A0	B0
PMR25	8.0±0.3	3.5±0.05	1.75±0.1	3.0±0.1	3.5±0.1
PMR50	12.0±0.3	5.5±0.05	1.75±0.1	2.9±0.2	5.3±0.2
PMR100	12.0±0.3	5.5±0.05	1.75±0.1	3.5±0.2	6.7±0.2

Part No.	D0	P0	P1	P2	T2
PMR25	φ1.5 ^{+0.1} ₀	4.0±0.1	4.0±0.1	2.0±0.05	Max 1.1
PMR50	φ1.5 ^{+0.1} ₀	4.0±0.1	4.0±0.1	2.0±0.05	Max 1.1
PMR100	φ1.5 ^{+0.1} ₀	4.0±0.1	4.0±0.1	2.0±0.05	Max 1.1

●Reel Dimensions

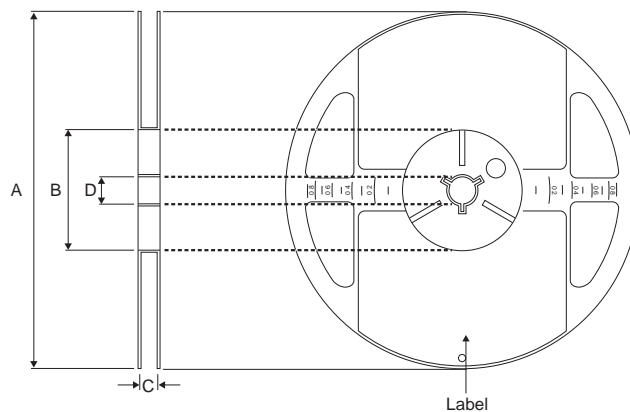

Label
ACCORDING TO EIAJ ET-7200B

(Unit : mm)

Part No.	A	B	C	D
☆ PMR006	φ180 _{-1.5} ⁰	φ60 ^{+1.0} ₀	9 ^{+1.0} ₀	φ13±0.2
PMR01				
PMR03				
PMR10				
PMR18			13 ^{+1.0} ₀	
PMR25				
PMR50				
PMR100				

☆ : Under development

Notes

- 1) The information contained herein is subject to change without notice.
- 2) Before you use our Products, please contact our sales representative and verify the latest specifications :
- 3) Although ROHM is continuously working to improve product reliability and quality, semiconductors can break down and malfunction due to various factors.
Therefore, in order to prevent personal injury or fire arising from failure, please take safety measures such as complying with the derating characteristics, implementing redundant and fire prevention designs, and utilizing backups and fail-safe procedures. ROHM shall have no responsibility for any damages arising out of the use of our Products beyond the rating specified by ROHM.
- 4) Examples of application circuits, circuit constants and any other information contained herein are provided only to illustrate the standard usage and operations of the Products. The peripheral conditions must be taken into account when designing circuits for mass production.
- 5) The technical information specified herein is intended only to show the typical functions of and examples of application circuits for the Products. ROHM does not grant you, explicitly or implicitly, any license to use or exercise intellectual property or other rights held by ROHM or any other parties. ROHM shall have no responsibility whatsoever for any dispute arising out of the use of such technical information.
- 6) The Products are intended for use in general electronic equipment (i.e. AV/OA devices, communication, consumer systems, gaming/entertainment sets) as well as the applications indicated in this document.
- 7) The Products specified in this document are not designed to be radiation tolerant.
- 8) For use of our Products in applications requiring a high degree of reliability (as exemplified below), please contact and consult with a ROHM representative : transportation equipment (i.e. cars, ships, trains), primary communication equipment, traffic lights, fire/crime prevention, safety equipment, medical systems, servers, solar cells, and power transmission systems.
- 9) Do not use our Products in applications requiring extremely high reliability, such as aerospace equipment, nuclear power control systems, and submarine repeaters.
- 10) ROHM shall have no responsibility for any damages or injury arising from non-compliance with the recommended usage conditions and specifications contained herein.
- 11) ROHM has used reasonable care to ensure the accuracy of the information contained in this document. However, ROHM does not warrant that such information is error-free, and ROHM shall have no responsibility for any damages arising from any inaccuracy or misprint of such information.
- 12) Please use the Products in accordance with any applicable environmental laws and regulations, such as the RoHS Directive. For more details, including RoHS compatibility, please contact a ROHM sales office. ROHM shall have no responsibility for any damages or losses resulting from non-compliance with any applicable laws or regulations.
- 13) When providing our Products and technologies contained in this document to other countries, you must abide by the procedures and provisions stipulated in all applicable export laws and regulations, including without limitation the US Export Administration Regulations and the Foreign Exchange and Foreign Trade Act.
- 14) This document, in part or in whole, may not be reprinted or reproduced without prior consent of ROHM.



Thank you for your accessing to ROHM product informations.
More detail product informations and catalogs are available, please contact us.

ROHM Customer Support System

<http://www.rohm.com/contact/>